

Features

- Low On-Resistance: 7.0Ω typical.
- V_{CC} Range: 2.7V to 4.2V ±10%
- Switching Speed 20nS
- Break-Before-Make Switching
- Extended Industrial Temperature Range: -40°C to 85°C
- LoPro™ Packaging (Pb-free): 10-Lead Micro Package
- Bandwidth 400MHz @ -3dB roll-off.
- Compatible with 1.8V systems.
- Power off protection.

Applications

- Hand Held Devices
- Cell Phones
- PDA's
- Notebooks
- LCD Monitors
- Set Top Box
- USB2.0 Applications

Pin Definitions

Pin No.	Name	Description
8	\overline{OE}	Switch Enable
3	GND	Ground
4,5,6,7	HSD1n, HSD2n.	Multiplexed DATA I/O
1,2	D+, D-	Common Port / USB DATA
9	V _{CC}	Positive Power Supply
10	SEL	Switch Select

Logic Function Table

\overline{OE}	SEL	Function
H	X	I/O's = Hi-Z
L	L	D+,D- = HSD1+, HSD1-
L	H	D+,D- = HSD2+,HSD2-.

Description

ProTek Analog's PA2070 is a bidirectional two-port Hi-speed switch. Configured as a double-pole double throw (DPDT), it is optimized for 400MHz switching.

The bandwidth of 400MHz allows passing of the 2nd Harmonic, resulting in minimal edge and phase distortion.

Superior channel to channel crosstalk minimizes interference.

The PA2070 contains circuitry for Power-Off protection when V_{CC} = 0V. Data pins can tolerate up to 5.5V

The PA2070 is compatible with 1.8 and 1.4V Systems.

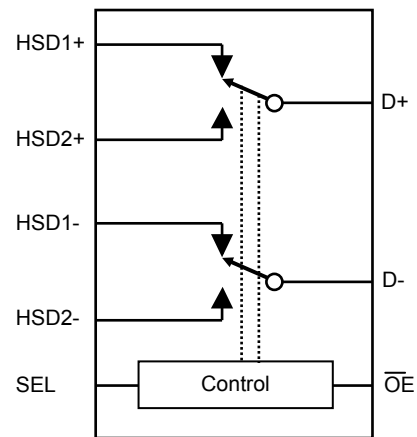
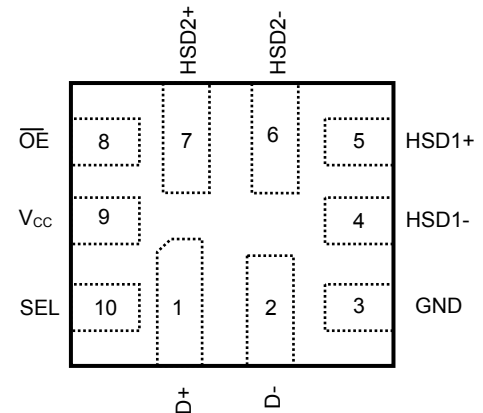
Functional Block Diagram

Pin Configuration (Top through View)

Temperature Range	Package	Part Number
-40 to 85 °C	10 Lead LoPro	PA2070-T7

Absolute Maximum Ratings⁽¹⁾

Storage Temperature Range-65°C to +150°C

Supply Voltage.....	-0.5V to 4.6V
DC Input Voltage.....	-0.5V to V _{CC} +0.5V
DC Output Current.....	±120mA
Power Dissipation (P _D) @ +85°C.....	500mW

Notes:-

1. "Absolute Maximum Ratings" may cause permanent damage to the device. This is a stress only rating and operation of the device at these or any other conditions beyond those indicated in the operational sections of this specification is not implied.
2. The input and output negative voltage ratings may be exceeded if the input and output diode current ratings are observed.
3. Control input must be held HIGH or LOW; it must not float

Recommended operating Conditions

SYMBOL	PARAMETER	MIN	MAX	UNIT
V _{CC}	Supply Voltage	2.7	4.2	V
V _{CNTRL}	Control Input Voltage	0	V _{CC}	V
V _{SW}	Switch I/O Voltage	-0.5	4.5	V
T _A	Operating Temperature			°C

DC Electrical Characteristics

SYMBOL	PARAMETER	CONDITIONS	V _{CC} (V)	T _A = 40 °C to +85 °C			UNITS
				MIN	TYP	MAX	
V _{IK}	Clamp Diode Voltage	I _{IN} = 18mA	3.0			-1.2	V
V _{IH}	Input Voltage High		3.0 to 3.6	1.3			V
			4.2	1.7			V
V _{IL}	Input Voltage Low		3.0 to 3.6			0.5	V
			4.2			0.7	V
I _{IN}	Control Input Leakage	V _{SW} = 0 to V _{CC}	4.2	-1		1	µA
I _{OZ}	Off State Leakage	0 ≤ Dn, HSD1n, HSD2n ≤ 3.6V	4.2	-2		2	µA
I _{OFF}	Power Off Leakage Current	V _{SW} = 0V to 4.3V, V _{CC} = 0V See Figure 4.	0	-2		2	µA
R _{ON}	Switch On Resistance ⁽¹⁾	V _{SW} = 0V to 4.3V, I _{ON} = -8mA See Figure 3.	3.0		7		Ω
ΔR _{ON}	Delta R _{ON} ⁽²⁾	V _{SW} = 0.4V, I _{ON} = -8mA	3.0		0.6		Ω
I _{CC}	Quiescent Supply Current	V _{CNTRL} = 0 or V _{CC} , I _{OUT} = 0	4.2			1.0	µA
I _{CCT}	Increase in I _{CC} per Control Voltage and V _{CC}	V _{CNTRL} = 2.6V, V _{CC} = 4.3V	4.2			10.0	µA
		V _{CNTRL} = 1.8V, V _{CC} = 4.3V	4.2			15.0	µA

Notes:

1. Measured by voltage drop between HSDn and Dn pins at the indicated current through the switch.
2. Guaranteed by characterization

AC Electrical Characteristics

SYMBOL	PARAMETER	CONDITIONS	V _{CC} (V)	T _A = 40 °C to +85 °C			UNITS
				MIN	TYP	MAX	
t _{ON}	Turn-On Time S, \overline{OE} to Output	R _L = 50Ω, C _L = 5pF V _{SW} = 0.8V See Figure 5, Figure 6.	3.0 to 3.6		13	30	nS
t _{OFF}	Turn-Off Time S, \overline{OE} to Output	R _L = 50Ω, C _L = 5pF V _{SW} = 0.8V See Figure 5, Figure 6	3.0 to 3.6		12	25	nS
t _{PD}	Propagation Delay ⁽³⁾	R _L = 50Ω, C _L = 5pF	3.3		0.25		nS
t _{BBM}	Break-Before-Make	R _L = 50Ω, C _L = 5pF V _{SW} = 0.8V See Figure 7.	3.0 to 3.6	2.0		6.0	nS
O _{IRR}	Off Isolation	R _L = 50Ω, f = 240MHz See Figure 9.	3.0 to 3.6		-30		dB
X _{TALK}	Non-Adjacent Channel Crosstalk	R _L = 50Ω, f = 240MHz See Figure 10.	3.0 to 3.6		-45		dB
BW	-3dB Bandwidth	R _L = 50Ω, C _L = 0pF See Figure 8.	3.0 to 3.6		420		MHz
		R _L = 50Ω, C _L = 5pF See Figure 8.	3.0 to 3.6		400		MHz

Notes:

3. Guaranteed by characterization

USB High Speed Related AC Electrical Characteristics

SYMBOL	PARAMETER	CONDITIONS	V _{CC} (V)	T _A = 40 °C to +85 °C			UNITS
				MIN	TYP	MAX	
t _{SK(P)}	Skew of Opposite Transitions of the same Output	R _L = 50Ω, C _L = 5pF.	3.0 to 3.6		20		pS
t _J	Total Jitter ⁽⁴⁾	R _L = 50Ω, C _L = 5pF t _R =t _F =500pS (10 to 90%) at 480Mbps (PRBS=2 ¹⁵ -1)	3.0 to 3.6		200		pS

Notes:

4. Guaranteed by characterization

Capacitance

SYMBOL	PARAMETER	CONDITIONS	T _A = 40 °C to +85 °C			UNITS
			MIN	TYP	MAX	
C _{IN}	Control Pin Input Capacitance	V _{CC} = 0V		1.5		pF
C _{ON}	D+ / D- On Capacitance	V _{CC} = 3.3V, \overline{OE} = 0V, f=240MHz See Figure 12		3.7		
C _{OFF}	D1n, D2n Off Capacitance	V _{CC} = 3.3V, \overline{OE} = 3.3V See Figure 11		2.0		

Test Diagrams.

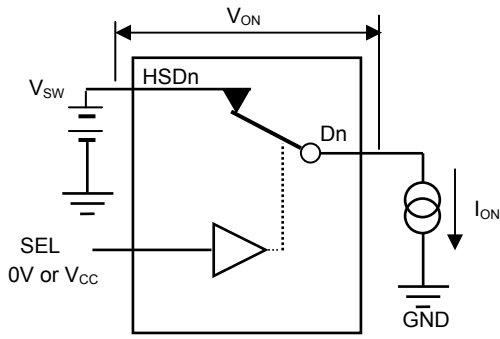

Fig.3 On Resistance

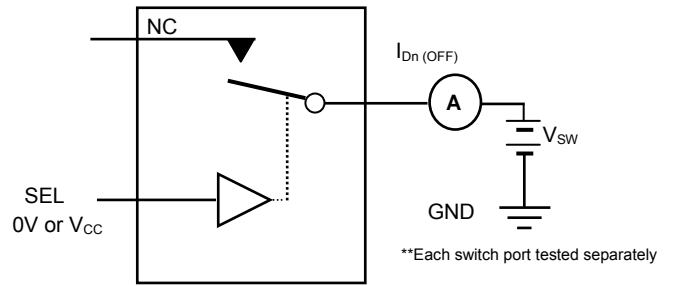

Fig.4 Off Leakage.

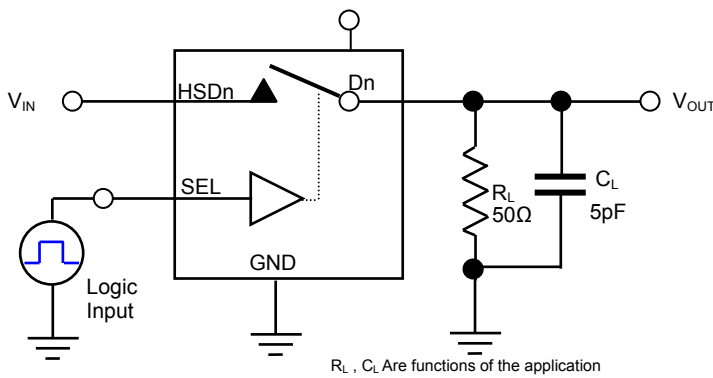

Fig.5 AC Test Circuit

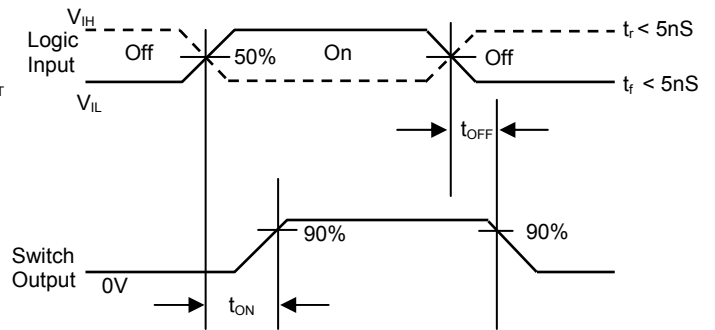

Fig.6 Turn-On / Turn-Off Waveforms

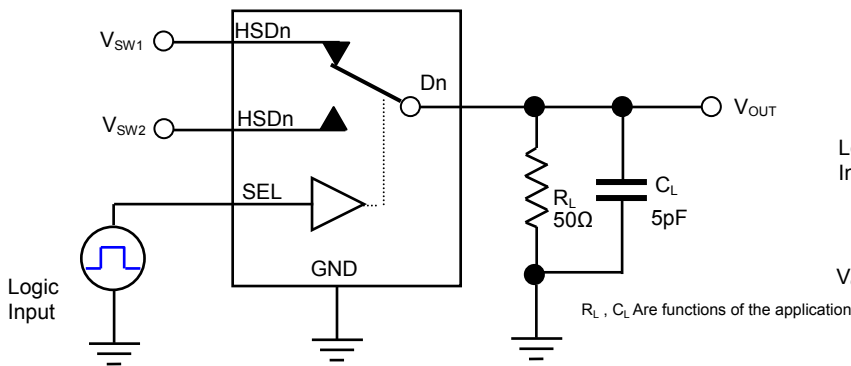
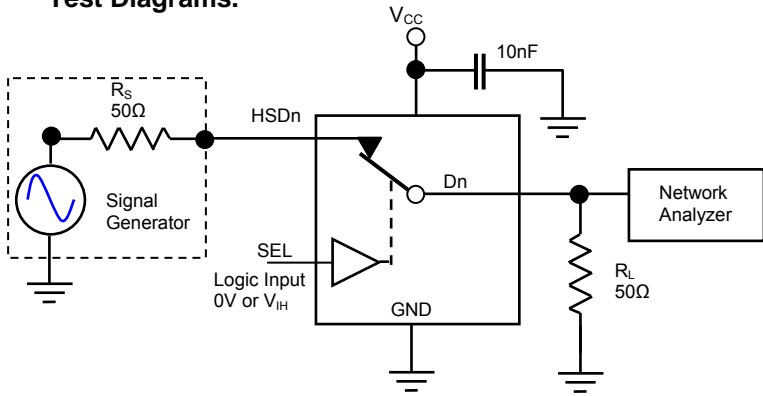

Fig.7 Break-Before-Make interval Timing

Test Diagrams.



RL, CL Are functions of the application

Fig.8 Bandwidth

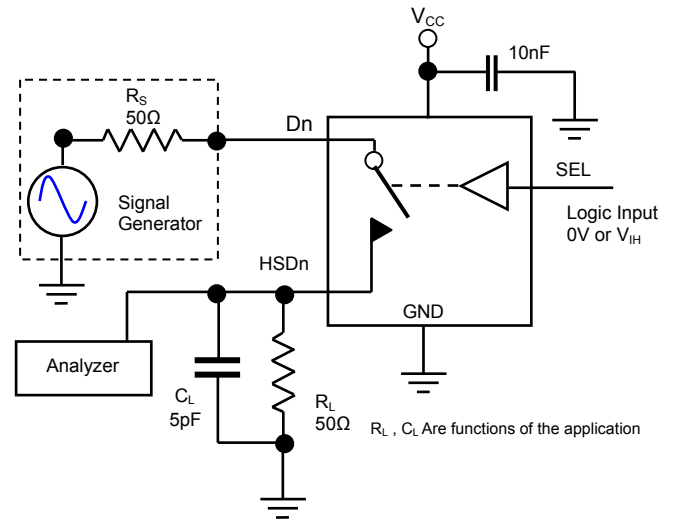

RL, CL Are functions of the application

Fig.9 Channel Off Isolation

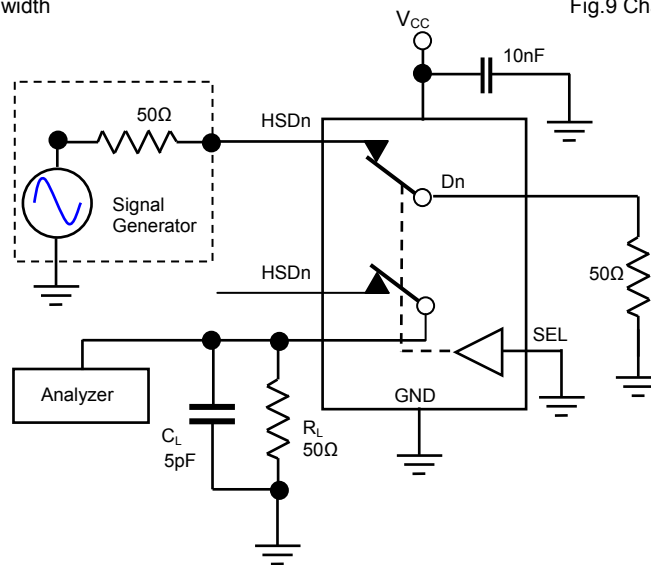

Fig.10 Non-Adjacent Channel-to-Channel Crosstalk

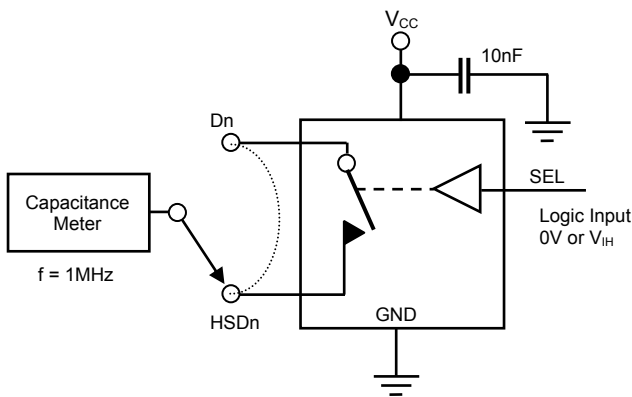

Fig.11 Channel Off Capacitance.

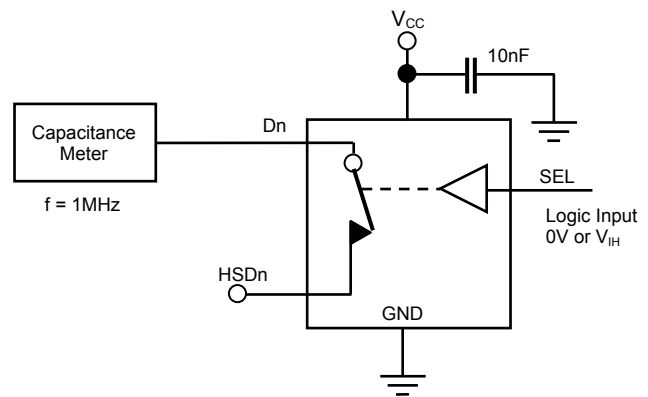
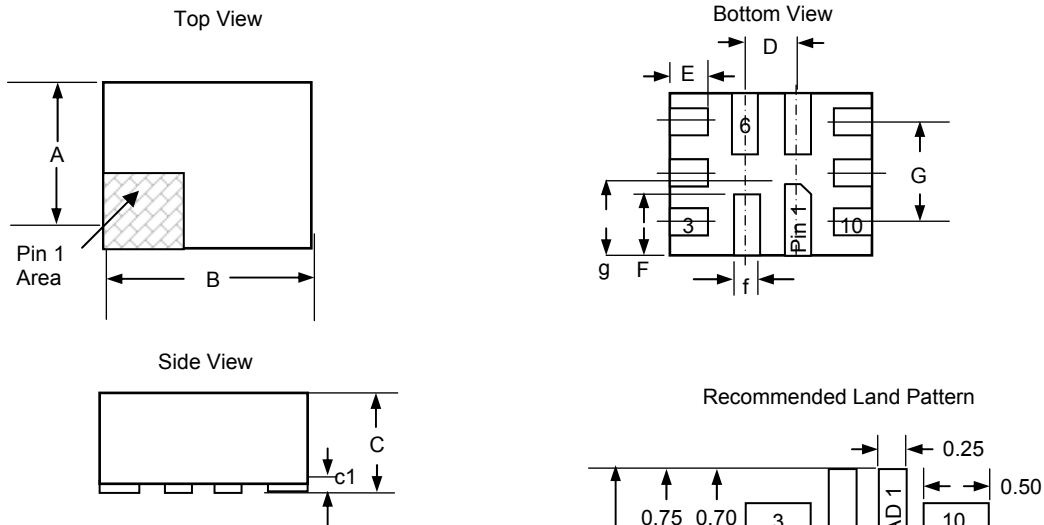

Fig.12 Channel On Capacitance.

Package Layout and Dimensions



DIM	MIN	TYP	Max
A	1.25	1.30	1.35
B	1.55	1.60	1.65
C	0.50	0.55	0.60
D	0.40		
E	0.29	0.30	0.31
F	0.49	0.50	0.51
G	0.80 REF		
c	0.00 - 0.05		
c1	0.10 REF		
f	0.15	0.20	0.25
g	0.59	0.60	0.61

Note: Dimensions in millimeters

Tape and Reel Specifications

Reel Dia	A0	B0	K0	D	E	F	W	P0	P2	P	t-max
178 (7")	1.47±0.05	1.73±0.05	0.65±0.05	1.50±0.10	1.75±0.10	3.50±0.05	12.00±0.30	4.00±0.10	2.00±0.05	4.00±0.10	0.25

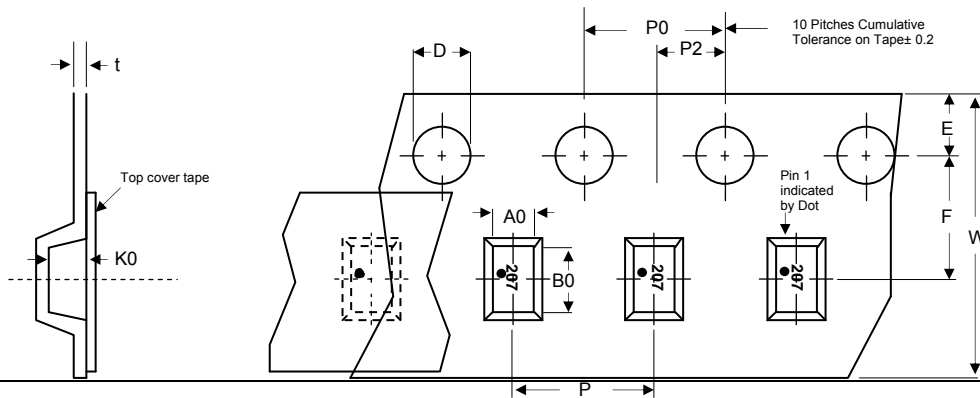

561 E. Elliot Road #175 Chandler, AZ 85225 Tel: (480) 539-2900. Fax: (480) 632-1715

