

MPQ2906
MPQ2907

PNP SILICON QUAD TRANSISTOR

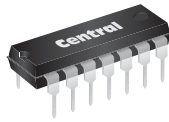

TO-116 CASE



www.centrasemi.com

DESCRIPTION:

The CENTRAL SEMICONDUCTOR MPQ2906, MPQ2907 types are comprised of four independent PNP silicon transistors mounted in a 14-pin DIP, designed for small signal, general purpose amplifier and switching applications.

MARKING: FULL PART NUMBER

MAXIMUM RATINGS: ($T_A=25^\circ\text{C}$)

Collector-Base Voltage
Collector-Emitter Voltage
Emitter-Base Voltage
Continuous Collector Current
Power Dissipation (per transistor)
Power Dissipation (total package)
Operating and Storage Junction Temperature

SYMBOL

V_{CBO} 60
 V_{CEO} 40
 V_{EBO} 5.0
 I_C 600
 P_D 650
 P_D 2.0
 T_J, T_{stg} -65 to +150

UNITS

V
V
V
mA
mW
W
 $^\circ\text{C}$

ELECTRICAL CHARACTERISTICS PER TRANSISTOR: ($T_A=25^\circ\text{C}$)

SYMBOL	TEST CONDITIONS	MIN	TYP	MAX	UNITS
I_{CBO}	$V_{CB}=30\text{V}$			50	nA
I_{EBO}	$V_{EB}=3.0\text{V}$			50	nA
BV_{CBO}	$I_C=10\mu\text{A}$	60			V
BV_{CEO}	$I_C=10\text{mA}$	40			V
BV_{EBO}	$I_E=10\mu\text{A}$	5.0			V
$V_{CE(SAT)}$	$I_C=150\text{mA}, I_B=15\text{mA}$			0.4	V
$V_{CE(SAT)}$	$I_C=300\text{mA}, I_B=30\text{mA}$			1.6	V
$V_{BE(SAT)}$	$I_C=150\text{mA}, I_B=15\text{mA}$			1.3	V
$V_{BE(SAT)}$	$I_C=300\text{mA}, I_B=30\text{mA}$			2.6	V
f_T	$V_{CE}=20\text{V}, I_C=50\text{mA}, f=100\text{MHz}$	200			MHz
C_{ob}	$V_{CB}=10\text{V}, I_E=0, f=1.0\text{MHz}$			8.0	pF
C_{ib}	$V_{BE}=2.0\text{V}, I_C=0, f=1.0\text{MHz}$			30	pF
t_{on}	$V_{CC}=30\text{V}, I_C=150\text{mA}, I_{B1}=15\text{mA}$		30		ns
t_{off}	$V_{CC}=6.0\text{V}, I_C=150\text{mA}, I_{B1}=I_{B2}=15\text{mA}$		150		ns

		MPQ2906		MPQ2907	
		MIN	MAX	MIN	MAX
h_{FE}	$V_{CE}=10\text{V}, I_C=10\text{mA}$	35	-	75	-
h_{FE}	$V_{CE}=10\text{V}, I_C=150\text{mA}$	40	-	100	-
h_{FE}	$V_{CE}=10\text{V}, I_C=300\text{mA}$	30	-	50	-

R1 (30-January 2012)

MPQ2906
MPQ2907

PNP SILICON QUAD TRANSISTOR



TO-116 CASE - MECHANICAL OUTLINE

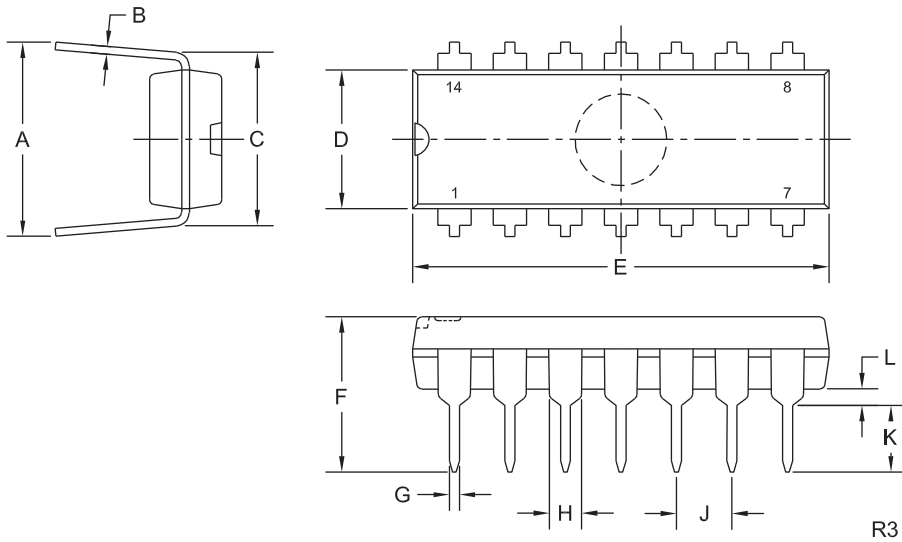

PIN CONFIGURATION

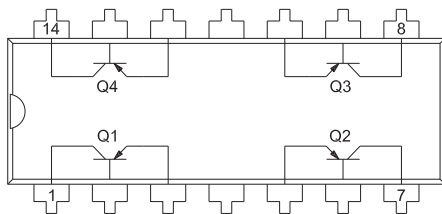

LEAD CODE:

- | | |
|------------------|-------------------|
| 1) Collector Q1 | 8) Collector Q3 |
| 2) Base Q1 | 9) Base Q3 |
| 3) Emitter Q1 | 10) Emitter Q3 |
| 4) No Connection | 11) No Connection |
| 5) Emitter Q2 | 12) Emitter Q4 |
| 6) Base Q2 | 13) Base Q4 |
| 7) Collector Q2 | 14) Collector Q4 |

SYMBOL	DIMENSIONS		DIMENSIONS	
	INCHES		MILLIMETERS	
	MIN	MAX	MIN	MAX
A	0.310	0.390	7.9	9.9
B	0.008	0.014	0.2	0.4
C	0.310		7.9	
D	0.240	0.260	6.1	6.6
E	0.740	0.760	18.8	19.3
F	-	0.300	-	7.6
G	0.014	0.022	0.4	0.6
H	0.050		1.3	
J	0.100		2.5	
K	0.125	0.150	3.2	3.8
L	0.015	-	0.4	-

TO-116 (REV: R3)

MARKING: FULL PART NUMBER

R1 (30-January 2012)