



- Ideal for 916.5 MHz FCC Part 15 Transmitters
- Very Low Series Resistance
- Quartz Stability
- Complies with Directive 2002/95/EC (RoHS)



The RO2144D is a true one-port, surface-acoustic-wave (SAW) resonator in a surface-mount ceramic case. It provides reliable, fundamental-mode stabilization of fixed-frequency transmitters operating at 916.5 MHz. This SAW is designed specifically for remote-control and data-link transmitters operating in the USA under FCC Part 15 regulations.

RO2144D
RO2144D-1
RO2144D-2

916.5 MHz
SAW
Resonator

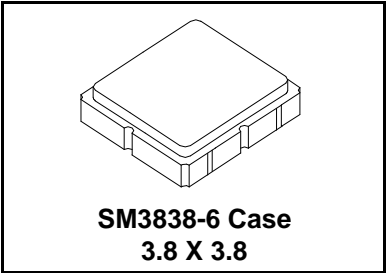

Absolute Maximum Ratings

Rating	Value	Units
Input Power Level	10	dBm
DC Voltage	12	VDC
Storage Temperature	-40 to +85	°C
Soldering Temperature (10 seconds / 5 cycles max.)	260	°C

Electrical Characteristics

Characteristic	Sym	Notes	Minimum	Typical	Maximum	Units	
Frequency (+25 °C) Nominal Frequency	RO2144D RO2144D-1 RO2144D-2	f_c	2, 3, 4, 5	916.405		916.595	MHz
				916.300		916.700	
				916.350		916.650	
Tolerance from 916.5 MHz	RO2144D RO2144D-1 RO2144D-2	Δf_c			±95	kHz	
					±200		
					±150		
Insertion Loss	IL	2, 5, 6		1.20	2.5	dB	
Quality Factor	Unloaded Q	Q_U		23,509			
	50 Ω Loaded Q	Q_L	5, 6, 7	4,000			
Temperature Stability	Turnover Temperature	T_O	10	25	40	°C	
	Turnover Frequency	f_O	6, 7, 8	f_c		MHz	
	Frequency Temperature Coefficient	FTC		0.032		ppm/°C ²	
Frequency Aging	Absolute Value during the First Year	fA	1	10		ppm	
DC Insulation Resistance between Any Two Terminals		5	1.0			M Ω	
RF Equivalent RLC Model	Motional Resistance	R_M		14.95		Ω	
	Motional Inductance	L_M	5, 6, 7, 9	21.94		μ H	
	Motional Capacitance	C_M		1.37		fF	
	Transducer Static Capacitance	C_P	5, 6, 9	1.95		pF	
Test Fixture Shunt Inductance	L_{TEST}	2, 7		15.05		nH	
Lid Symbolization	RO2144D 432/YWWS, RO2144D-1 493/YWWS, RO2144D-2 537/YWWS						
Standard Reel Quantity	Reel Size 7 Inch		10	500 Pieces / Reel			
	Reel Size 13 Inch			3000 Pieces / Reel			



CAUTION: Electrostatic Sensitive Device. Observe precautions for handling.

Notes:

- Frequency aging is the change in f_c with time and is specified at +65°C or less. Aging may exceed the specification for prolonged temperatures above +65°C. Typically, aging is greatest the first year after manufacture, decreasing in subsequent years.
- The center frequency, f_c , is measured at the minimum insertion loss point, IL_{MIN} , with the resonator in the 50 Ω test system (VSWR \leq 1.2:1). The shunt inductance, L_{TEST} , is tuned for parallel resonance with C_O at f_c . Typically, $f_{OSCILLATOR}$ or $f_{TRANSMITTER}$ is approximately equal to the resonator f_c .
- One or more of the following United States patents apply: 4,454,488 and 4,616,197.
- Typically, equipment utilizing this device requires emissions testing and government approval, which is the responsibility of the equipment manufacturer.
- Unless noted otherwise, case temperature $T_C = +25^\circ\text{C} \pm 2^\circ\text{C}$.
- The design, manufacturing process, and specifications of this device are subject to change without notice.
- Derived mathematically from one or more of the following directly measured parameters: f_c , IL, 3 dB bandwidth, f_c versus T_C , and C_O .
- Turnover temperature, T_O , is the temperature of maximum (or turnover) frequency, f_O . The nominal frequency at any case temperature, T_C , may be calculated from: $f = f_O [1 - FTC (T_O - T_C)^2]$. Typically oscillator T_O is approximately equal to the specified resonator T_O .
- This equivalent RLC model approximates resonator performance near the resonant frequency and is provided for reference only. The capacitance C_O is the static (nonmotional) capacitance between the two terminals measured at low frequency (10 MHz) with a capacitance meter. The measurement includes parasitic capacitance with "NC" pads unconnected. Case parasitic capacitance is approximately 0.05 pF. Transducer parallel capacitance can be calculated as: $C_P = C_O - 0.05 \text{ pF}$.
- Tape and Reel Standard Per ANSI/EIA 481.

916.5 MHz

SAW Resonator

Electrical Connections

The SAW resonator is bidirectional and may be installed with either orientation. The two terminals are interchangeable and unnumbered. The callout NC indicates no internal connection. The NC pads assist with mechanical positioning and stability. External grounding of the NC pads is recommended to help reduce parasitic capacitance in the circuit.

Pin	Connection
1	NC
2	Terminal
3	NC
4	NC
5	Terminal
6	NC

Power Test

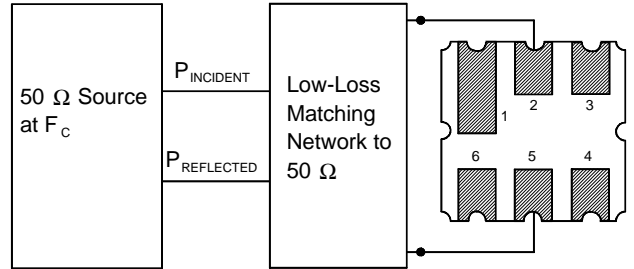

Typical Application Circuits

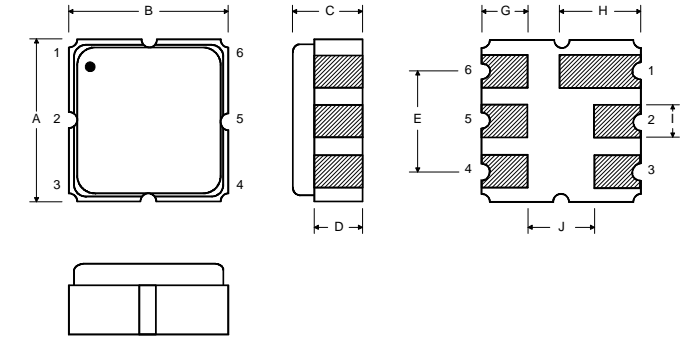
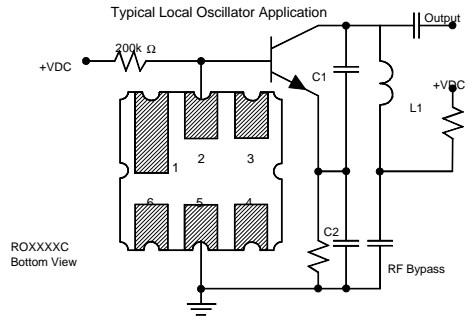
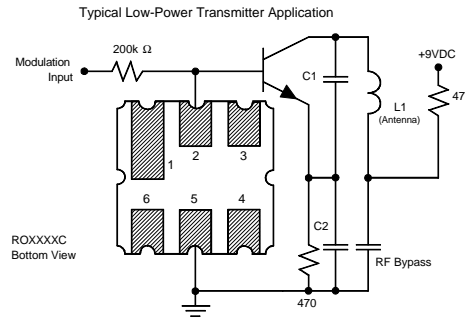

Case Dimensions

Dimension	mm			Inches		
	Min	Nom	Max	Min	Nom	Max
A	3.60	3.80	4.0	0.14	0.15	0.16
B	3.60	3.80	4.0	0.14	0.15	0.16
C	1.00	1.20	1.40	0.04	0.05	0.055
D	0.95	1.10	1.25	0.037	0.043	0.05
E	2.39	2.54	2.69	0.090	0.10	0.110
G	0.90	1.0	1.10	0.035	0.04	0.043
H	1.90	2.0	2.10	0.75	0.08	0.83
I	0.50	0.6	0.70	0.020	0.024	0.028
J	1.70	1.8	1.90	0.067	0.07	0.075

Typical Test Circuit

The test circuit inductor, L_{TEST} , is tuned to resonate with the static capacitance, C_O , at F_C .

Electrical Test

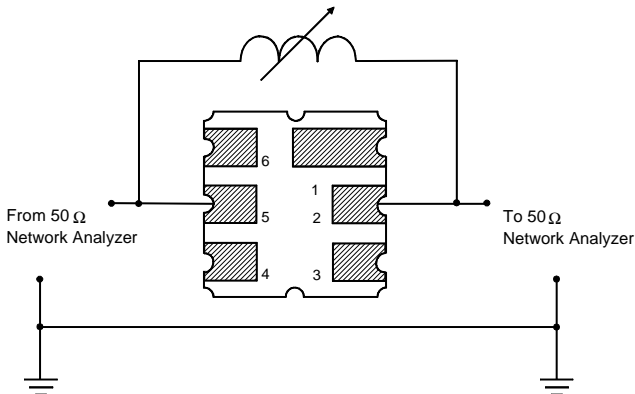

Equivalent LC Model

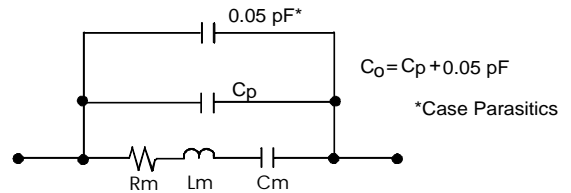

Temperature Characteristics

The curve shown on the right accounts for resonator contribution only and does not include LC component temperature contributions.

