

T-33-05

FEATURES

- HIGH GAIN BANDWIDTH PRODUCT: $f_r = 1.7$ GHz
- LOW NOISE FIGURE AT 200 MHz: $NF = 2.7$ dB
- LOW DISTORTION
- HIGH POWER GAIN
- RELIABLE

DESCRIPTION AND APPLICATIONS

The NE741 series of NPN epitaxial silicon transistors is designed for wide bandwidth UHF and VHF amplifiers. Its low distortion and noise figures make it an excellent choice for CATV and MATV applications, especially those requiring higher than normal reliability. Besides the chip (NE74100) the series comes packaged in two versions of the TO-39 can. The NE74113 has the collector connected to the case whereas the NE74114 has all leads insulated from the case. The series is normally screened to NEC's Grade D level of reliability, but higher reliability screening is available depending upon customer requirements. Performance and quality are assured by QC procedures patterned after MIL-S-19500 and NEC's exclusive Pt-Si/Ti/Pt/Au metallization.

OUTLINE DIMENSIONS (Units In mm)

NE74100 (CHIP)

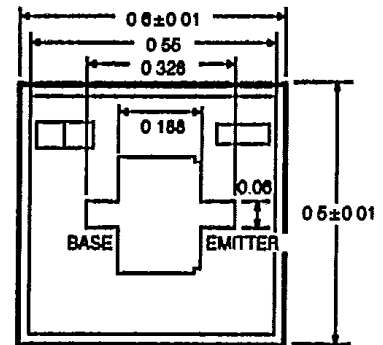

Chip Thickness: 140 μm

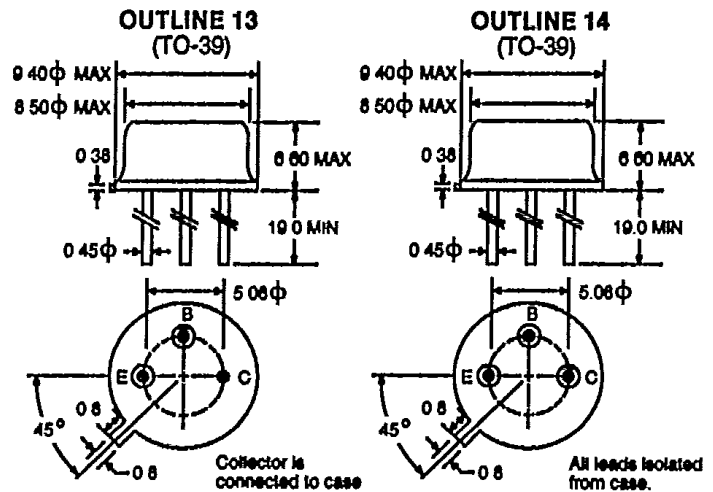

*All dimensions typical unless noted.

PERFORMANCE SPECIFICATIONS (T_A = 25 °C)

SYMBOLS	PARAMETERS AND CONDITIONS	UNITS	NE74113 2SC1365 13 (TO-39)			NE74114 2SC1252 14 (TO-39)		
			MIN	TYP	MAX	MIN	TYP	MAX
f_r	Gain Bandwidth Product at $V_{CE} = 15$ V, $I_c = 70$ mA	GHz	1.4	1.7		1.4	1.7	
$ S_{21E} ^2$	Insertion Power Gain at $V_{CE} = 15$ V, $I_c = 80$ mA $f = 0.2$ GHz $f = 0.5$ GHz $f = 1$ GHz	dB dB dB		15 8 3			15 8 3	
NF _{MIN}	Minimum Noise Figure at $V_{CE} = 15$ V, $I_c = 30$ mA, $R_a = 50$ Ω $f = 200$ MHz $V_{CE} = 15$ V, $I_c = 10$ mA ² $f = 200$ MHz	dB dB		3 2.7	4		3 2.7	4
MAG	Maximum Available Gain at $V_{CE} = 15$ V, $I_c = 50$ mA ² $f = 200$ MHz	dB	15	17		15	17	

Notes:

1. Electronic Industrial Association of Japan.
2. Input and output are tuned for optimum noise figure.
3. Maximum Available Gain (MAG) is calculated from the device S-Parameters using the equation,

$$MAG = \frac{|S_{21}|}{|S_{12}|} (K \pm \sqrt{K^2 - 1}) \quad K = \frac{1 + |\Delta|^2 - |S_{11}|^2 - |S_{22}|^2}{2|S_{21}| |S_{12}|} \quad \Delta = S_{11} S_{22} - S_{21} S_{12}$$

ELECTRICAL CHARACTERISTICS (TA = 25°C)

PART NUMBER EIAJ ¹ REGISTERED NUMBER PACKAGE OUTLINE			NE74113 2SC1365 13 (TO-39)			NE74114 2SC1252 14 (TO-39)		
SYMBOLS	PARAMETERS AND CONDITIONS	UNITS	MIN	TYP	MAX	MIN	TYP	MAX
ICBO	Collector Cutoff Current at VCB = 30 V, IE = 0	μA			0.1			0.1
IEBO	Emitter Cutoff Current at VEB = 2 V, IC = 0	μA			0.5			0.5
hFE	Forward Current Gain at VCE = 10 V ² , IC = 50 mA		20	80	200	20	80	200
COB	Output Capacitance at VCB = 15 V, IE = 0, f = 1 MHz ³	pF		2	3		2	3
RTH	Thermal Resistance (Junction to Case)	°C/W			35			35
PT	Total Power Dissipation (Tc = 25°C)	W			5 ⁴			5 ⁴

Notes:

1. Electronic Industrial Association of Japan.
2. Pulse Width ≤ 350 μs, Duty Cycle ≤ 2%/pulsed.
3. The emitter is grounded.
4. PT = 3.2 W at Tc = 88°C.

ABSOLUTE MAXIMUM RATINGS (TA = 25°C)

SYMBOLS	PARAMETERS	UNITS	RATINGS
VcBO	Collector to Base Voltage	V	45
VCEO	Collector to Emitter Voltage	V	25
VEBO	Emitter to Base Voltage	V	3
IC	Collector Current	mA	300
TJ	Junction Temperature	°C	200
TSTG	Storage Temperature	°C	-65 to +200

TYPICAL DEVICE CHARACTERISTICS (TA = 25°C)

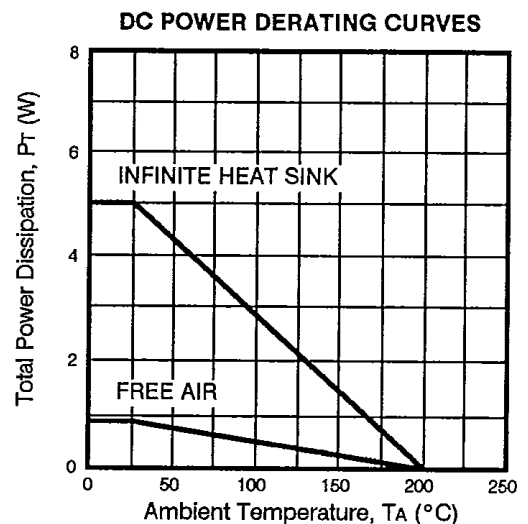
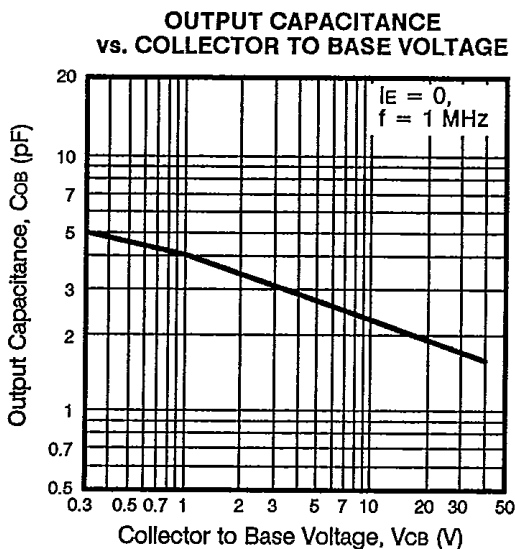

TYPICAL DEVICE CHARACTERISTICS ($T_A = 25^\circ\text{C}$)

COLLECTOR TO EMITTER VOLTAGE vs. BASE TO EMITTER RESISTANCE

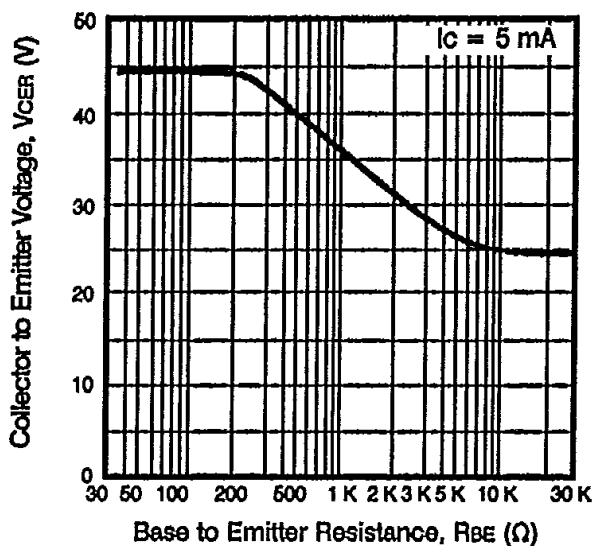

DC FORWARD CURRENT GAIN vs. COLLECTOR CURRENT

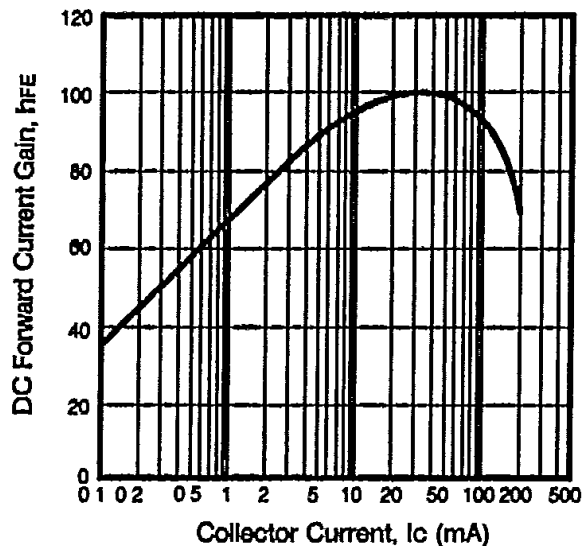

TYPICAL PERFORMANCE CHARACTERISTICS ($T_A = 25^\circ\text{C}$)

MAP OF THE GAIN BANDWIDTH PRODUCT

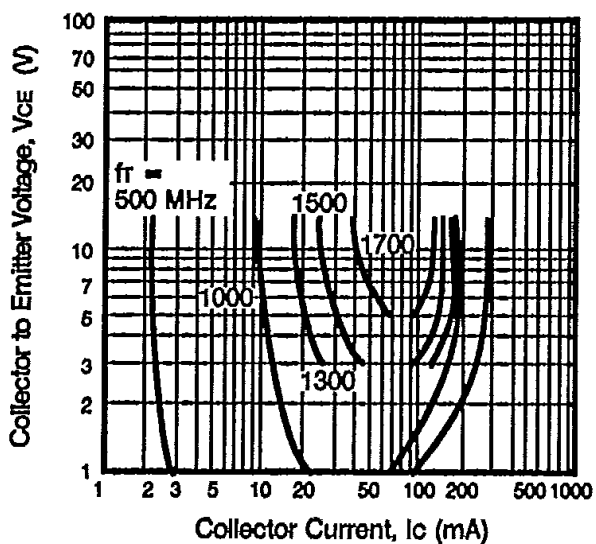

FORWARD INSERTION GAIN AND MAXIMUM AVAILABLE GAIN vs. FREQUENCY

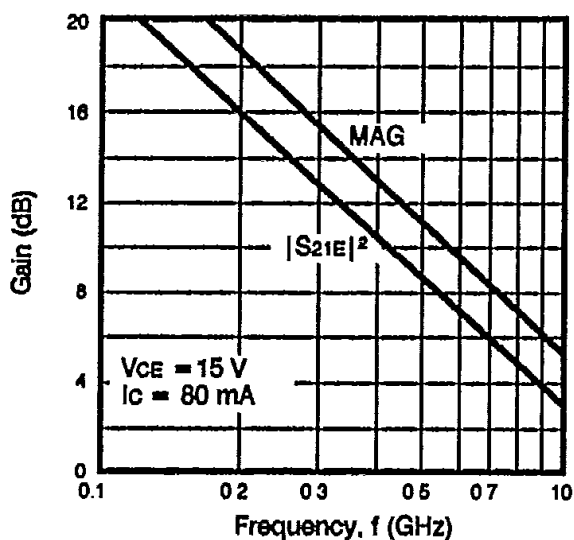

NOISE FIGURE vs. COLLECTOR CURRENT

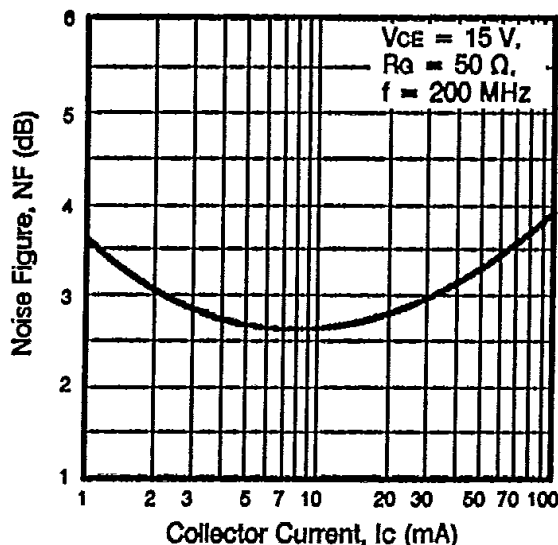

TYPICAL INTERMODULATION DISTORTION CHARACTERISTICS (TA = 25°C)

2ND ORDER INTERMODULATION DISTORTION vs. OUTPUT VOLTAGE USING TEST CIRCUIT NO. 1

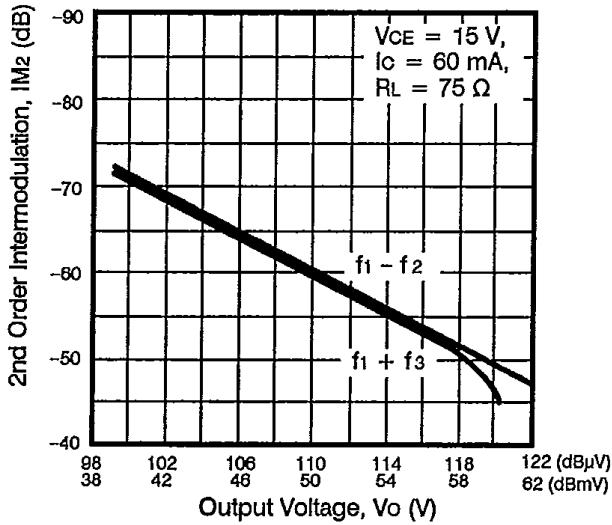

3RD ORDER INTERMODULATION DISTORTION vs. COLLECTOR CURRENT USING TEST CIRCUIT NO. 1

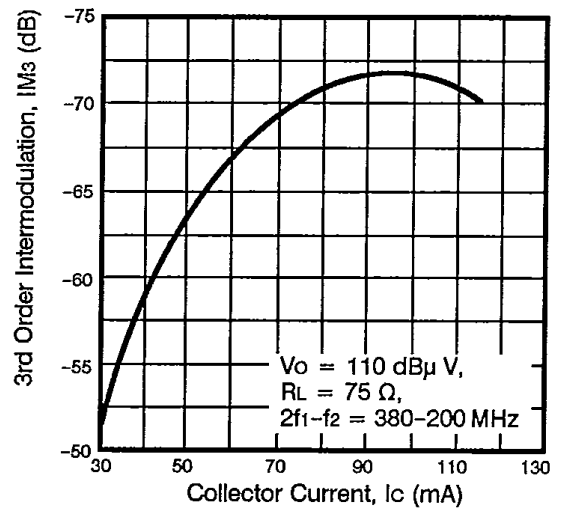

2ND ORDER INTERMODULATION DISTORTION vs. COLLECTOR CURRENT TEST CIRCUIT NO. 1

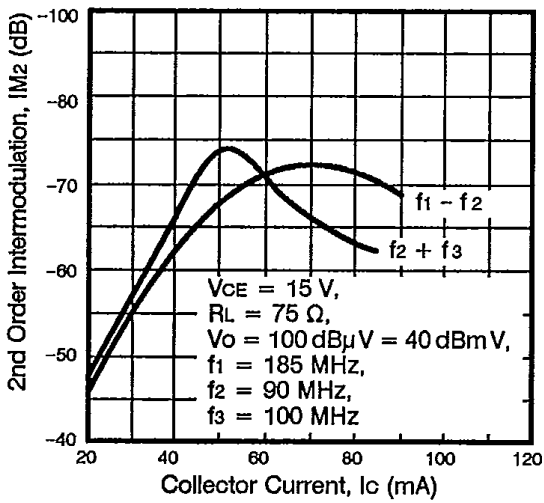

2ND ORDER INTERMODULATION DISTORTION vs. COLLECTOR CURRENT TEST CIRCUIT NO. 2

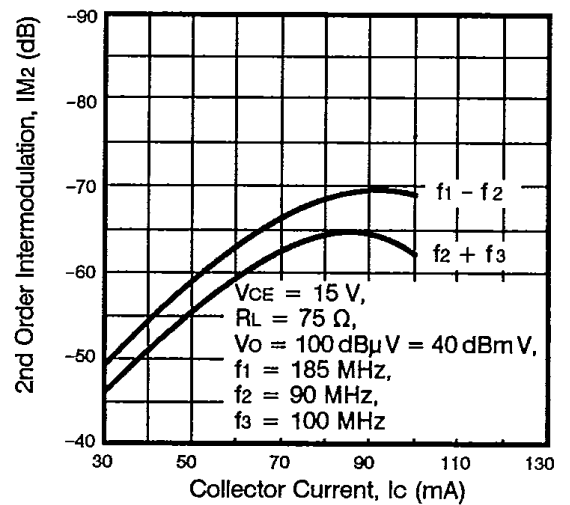

IM TEST CIRCUIT 1

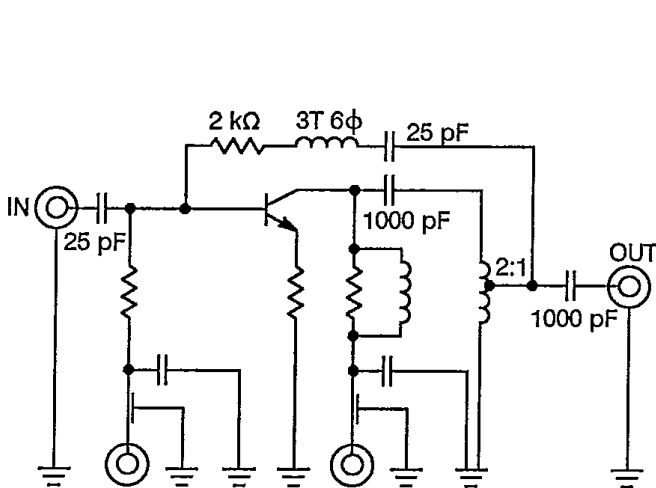

TEST CONDITION
 BANDWIDTH: 80 to 320 MHz
 VOLTAGE GAIN: 6 dB

IM TEST CIRCUIT 2

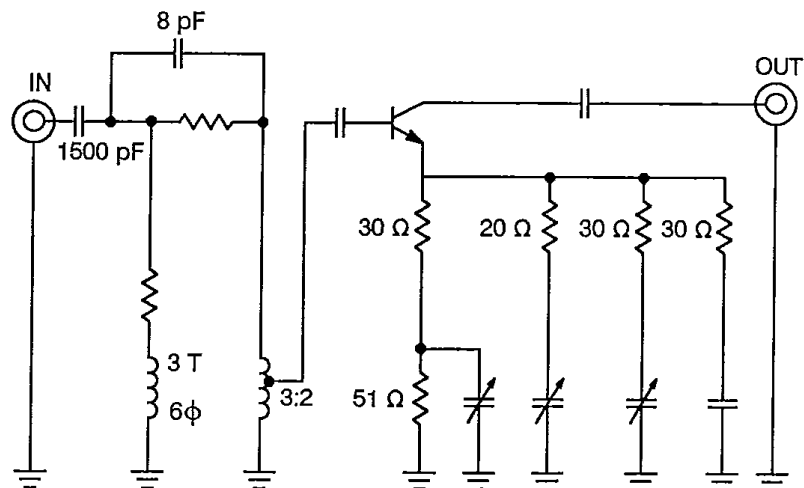

TEST CONDITION
 BANDWIDTH: 70 to 250 MHz
 VOLTAGE GAIN: 6 dB

TYPICAL COMMON EMITTER SCATTERING PARAMETERS

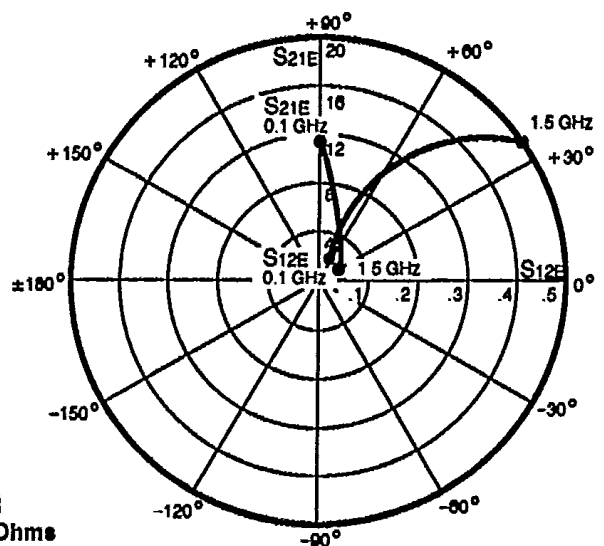
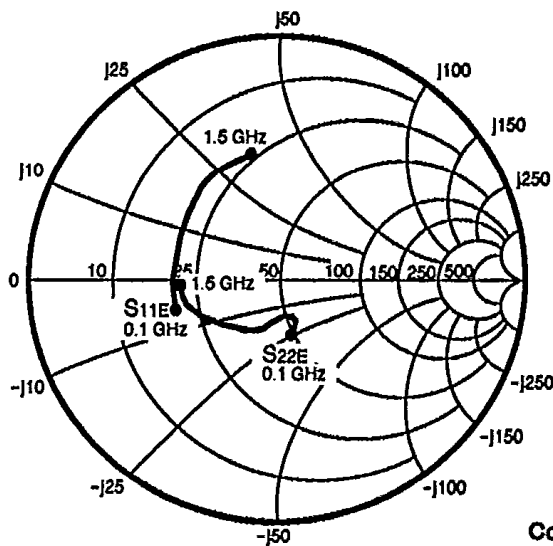

NE74113
Coordinates in Ohms
Frequency in GHz
(Vce = 15 V, Ic = 60 mA)

S-MAGN AND ANGLES:

VCE = 15 V, IC = 20 mA

FREQUENCY (MHz)

	S ₁₁		S ₂₁		S ₁₂		S ₂₂	
100	.42	-149	9.75	96	.05	62	.31	-54
200	.42	-172	5.08	81	.09	68	.24	-58
500	.45	158	2.15	56	.21	68	.24	-87
1000	.51	126	1.25	27	.39	55	.33	-135
1500	.56	100	.96	8	.56	40	.43	-174

VCE = 15 V, IC = 40 mA

100	.39	-158	10.48	93	.05	68	.25	-60
200	.39	-177	5.40	80	.09	72	.19	-65
500	.42	157	2.29	57	.22	68	.20	-94
1000	.48	126	1.33	28	.40	53	.29	-140
1500	.54	102	1.03	8	.55	39	.39	-176

VCE = 15 V, IC = 60 mA

100	.38	-162	10.75	92	.05	70	.23	-72
200	.38	-178	5.52	80	.09	72	.18	-68
500	.41	156	2.33	57	.22	67	.19	-97
1000	.47	127	1.36	28	.40	52	.27	-142
1500	.53	103	1.05	8	.54	38	.37	-176

VCE = 15 V, IC = 80 mA

100	.37	-163	10.79	92	.05	71	.21	-63
200	.38	-179	5.55	80	.10	73	.17	-70
500	.41	156	2.34	57	.22	67	.18	-99
1000	.47	127	1.37	28	.40	51	.27	-143
1500	.53	103	1.05	7	.55	38	.36	-177

TYPICAL COMMON EMITTER SCATTERING PARAMETERS

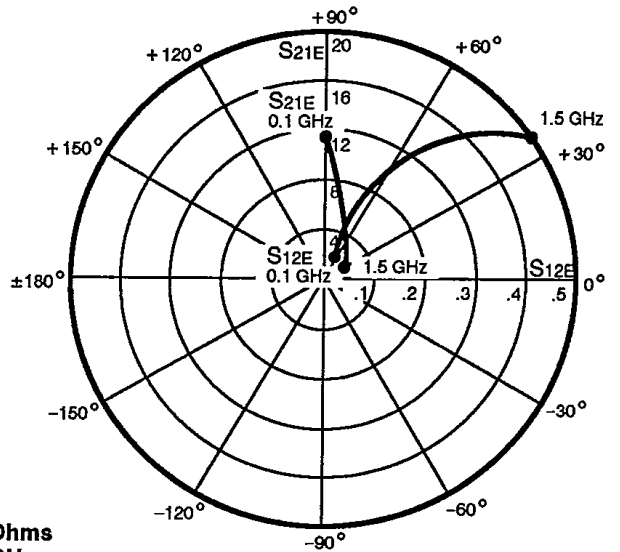
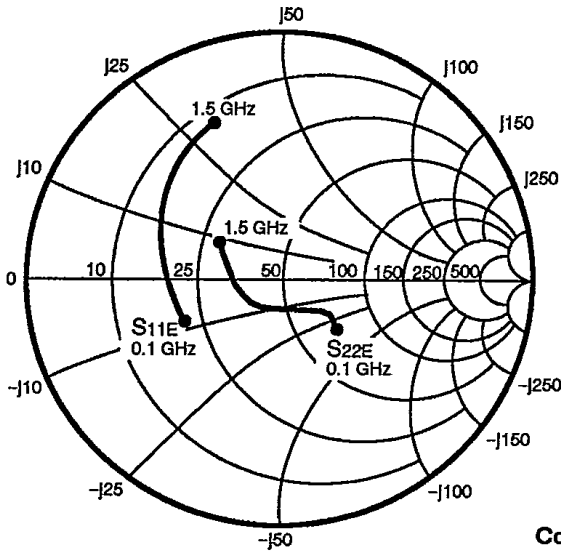

NE74114
Coordinates in Ohms
Frequency in GHz
(VCE = 15 V, IC = 60 mA)

S-MAGN AND ANGLES:

VCE = 15 V, IC = 20 mA

FREQUENCY (MHz)

	S11		S21		S12		S22	
100	.45	-145	10.29	97	.04	60	.38	-36
200	.44	-168	5.40	83	.07	67	.31	-34
500	.48	164	2.28	57	.17	70	.25	-51
1000	.58	134	1.33	25	.34	57	.19	-121
1500	.70	107	.98	0	.51	37	.32	153

VCE = 15 V, IC = 40 mA

100	.40	-153	11.22	95	.04	65	.32	-38
200	.41	-172	5.82	82	.07	71	.25	-35
500	.45	164	2.45	57	.18	69	.19	-51
1000	.56	135	1.42	25	.34	54	.13	-128
1500	.69	109	1.04	0	.50	35	.28	147

VCE = 15 V, IC = 60 mA

100	.39	-156	11.55	94	.04	68	.29	-39
200	.40	-173	5.98	81	.08	71	.23	-36
500	.44	164	2.51	57	.18	68	.17	-50
1000	.56	136	1.45	26	.34	53	.11	-134
1500	.69	109	1.07	0	.49	35	.27	143

VCE = 15 V, IC = 80 mA

100	.38	-157	11.70	93	.04	68	.27	-40
200	.39	-173	6.04	81	.08	72	.21	-36
500	.44	164	2.53	57	.18	68	.16	-50
1000	.56	136	1.46	26	.34	52	.10	-138
1500	.69	109	1.07	0	.49	34	.26	141