



Advantages

- Excellent signal-to-noise ratio
- Lower power consumption, 0.8mW
- <20µW power down mode

Applications

- Mobile handsets
- Notebook PC microphones

For more information, please visit:

www.fairchildsemi.com/pf/FA/FAN3850A.html
www.fairchildsemi.com/pf/FA/FAN3850T.html

Digital Microphones Improve Sound Quality, Lower Power

Achieve better sound quality in mobile handset and notebook microphone applications with Fairchild's FAN3850x series of digital microphone pre-amplifiers. These high performance analog mobile audio devices provide advanced noise rejection capabilities as well as an easy interface to mobile handset processors.

The series includes:

- FAN3850A that features both 16dB and 19dB gain versions,
- FAN3850T offering 15dB gain and integrated negative temperature coefficient to compensate for ECM positive temperature coefficient to achieve a flat sensitivity response over temperature.

Both devices integrate a pre-amplifier, low drop-out regulator (LDO) and analog-to-digital converter (ADC) that converts Electret Condenser Microphone (ECM) outputs to digital pulse density modulation (PDM) data streams.

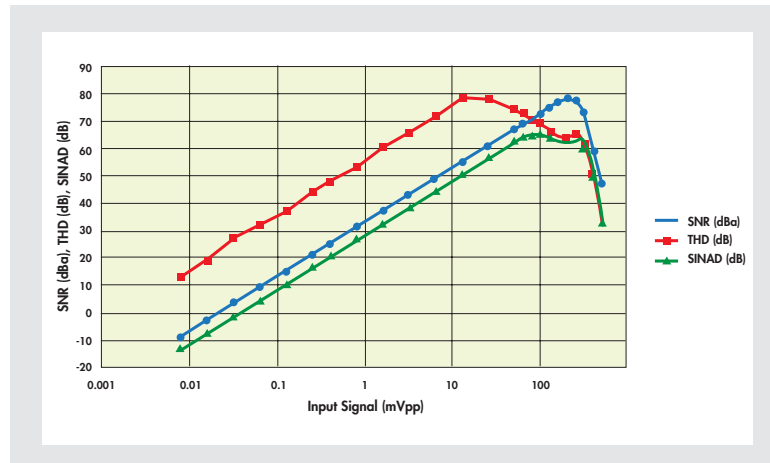

FAN3850T 15dB SNR (dBa), THD (-dB), SINAD (dB) over Input Amplitude

Product Number	I _{DD} (µA)	I _{SLEEP} (µA)	SNR (dB)	THD (%)	120dB SPL THD + N (%)	ESD (HBM) (kV)
FAN3850x	420	1.4	62	0.01	3	7

V_{DD} = 1.8V, F_{CLOCK} = 2.4MHz, 94dB SPL

SINGLE-CHIP PWM SOLUTION

Advantages

- Proven, reliable mWSaver™ Technology
- Achieves <30mW no load/standby power consumption
- Reduces up to 15 external components

Applications

- Notebooks
- Game consoles
- Printer adapters
- LCD TVs

For more information, please visit:

www.fairchildsemi.com/pf/FA/FAN6756.html
www.fairchildsemi.com/mwsaver

Single-Chip PWM Solution Saves Board Space

Designers who need to achieve lower standby power consumption in devices such as notebooks, printers, LCD TVs, now have an industry-leading single-chip solution with Fairchild's FAN6756. Lower standby power in $\leq 75W$ space-constrained applications is achieved without additional external circuitry, complex designs or higher costs. The single-chip solution is a highly integrated green-mode PWM controller that significantly reduces standby losses in SMPS designs, and eliminates up to 15 external components.

The FAN6756 also includes an innovative AX-CAP™ discharge method that minimizes losses in the EMI filter stage, while meeting the IEC61010-1 safety requirement. This functionality is achieved by eliminating the X-cap discharge resistors and discharging X-cap energy through the HV pin when the power is unplugged from the AC outlet.

Ideal for power supplies that demand extremely low standby power, the FAN6756 incorporates mWSaver™ Technology. This technology allows the device to reduce power losses not only in the controller, but also in the external circuits and components. It also includes a proprietary deep burst mode technology that reduces switching loss at no-load and light-load conditions.

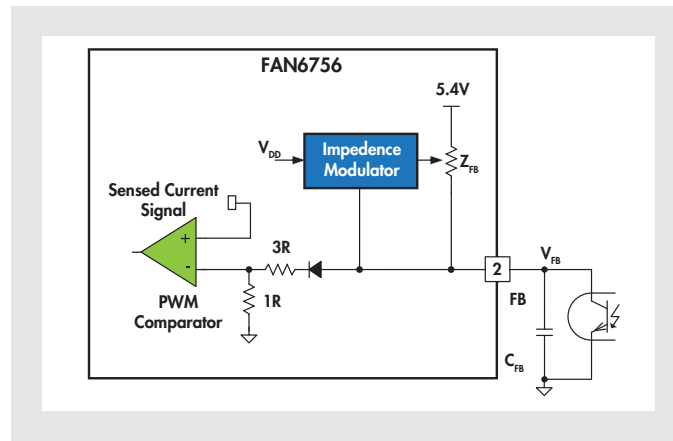

Deep Burst Mode Control Circuit

Product Number	Protection*				Max Power (W) Rating	Feedback Mode	Protection	Package
	OLP	OVP	OTP	SSCP				
FAN6756MRMY	A/R	L	L	A/R	65	Current	OLP, OCP, OVP, OTP, SSCP	SOIC-8
FAN6756MLMY	L	L	L	A/R				

*Auto Recovery Mode protection, L = Latch Mode protection.

Advantages

- Excellent CTR linearity at high temperature
- CTR at very low input current, I_F (1mA, 1.6mA, and 3mA)
- Small footprint: half-pitch mini-flat package (MFP) saves board real estate for more flexibility and overall systems cost savings

Applications

- Primarily suited for DC-DC converters
- Ground loop isolation, signal-to-noise isolation
- Communications: adapters, chargers
- Consumer: appliances, set-top boxes
- Industrial: power supplies, motor control, programmable logic control

For more information, please visit:

www.fairchildsemi.com/pf/FO/FODM8801A.html
www.fairchildsemi.com/products/opto/

Reliable Isolation and Minimized System Failure with OptoHiT™ Optocouplers

Realize increased design margins and stable parameters in high temperature environments with Fairchild's new FODM8801 OptoHiT™ high temperature phototransistor optocoupler. You'll achieve high noise immunity and reliable isolation at high operating temperatures, up to 125°C, as this new series implements Fairchild's proprietary OPTOPLANAR® coplanar packaging technology. In addition, the FODM8801 offers excellent CTR linearity and operates at a very low input current (I_F). The optocoupler consists of an aluminum gallium arsenide (AlGaAs) infrared light emitting diode optically coupled to a phototransistor.

Because the FODM8801 is packaged in a compact, half-pitch, mini-flat, 4-pin package (1.27mm lead pitch), benefits also include board space savings and design flexibility, ultimately allowing for overall reductions in system cost.

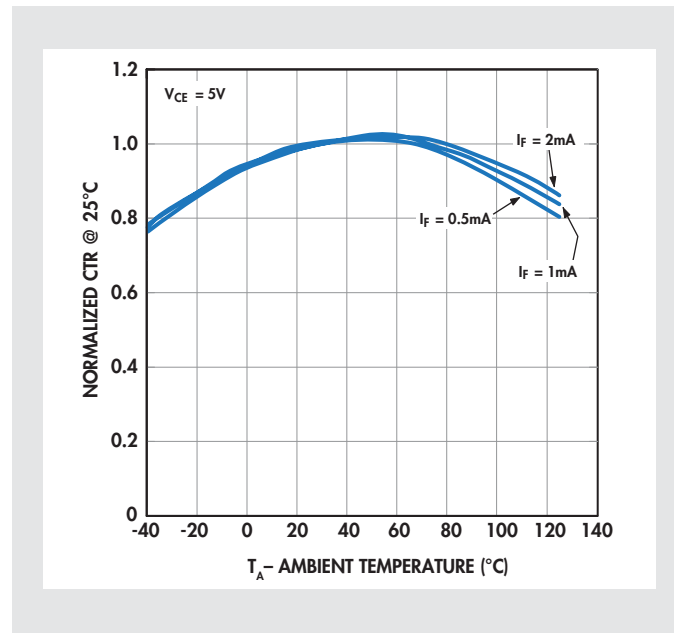

Normalized CTR vs. Ambient Temperature

Product Number	CTR (Min) @ $I_F = 1\text{mA}$	CTR (Max) @ $I_F = 1\text{mA}$	V_{CE0} (Min)	V_{ECO} (Min)	t_{ON}/t_{OFF} (Max)	V_{ISO} (Min)	T_{OPR} (Min)	T_{OPR} (Max)
FODM8801A	80%	160%	75V	7V	20µs	3750V	-40 °C	125 °C
FODM8801B	130%	260%						
FODM8801C	200%	400%						

Advantages

- High functional density in a small form factor
- Up to 60% board space savings compared to other solutions
- Up to 20% lower bill of material costs compared to other solutions
- Digital power factor (PF) realization greater than 0.9
- Lower total harmonic distortion (THD)
- 90% electrical efficiency
- Meets worldwide Energy Star® regulations

Applications

- Decorative lighting
- Low-power lighting

For more information, please visit:

www.fairchildsemi.com/pf/FL/FL7701.html
www.fairchildsemi.com/ledlighting

Engineering Connections

Need to Design a Dimmable LED Lamp Small Enough to Fit Existing Sockets?

Read the latest in our blog at www.fairchildsemi.com/engineeringconnections.

Small-Spaced Dimming Challenges Solved with LED Lamp Driver IC

With Fairchild's FL7701 smart non-isolated Buck LED driver with power factor correction, designers attain efficient dimming solutions that also fit within existing sockets. Because the need to work reliably in a small space while providing high efficiency is imperative, the device uses a digital technique that allows it to automatically detect the AC input voltage condition. A special internal reference signal is then created, resulting in high power factor correction. The FL7701 will work from a DC input voltage condition, automatically sensing AC versus DC input voltage conditions. It also combines high functional density to create the smallest form factor and allows designers to save up to 20% BOM costs and up to 60% board space savings.

The LED driver provides energy savings that meet the most stringent worldwide regulations, such as Energy Star®. Designers also benefit from the high degree of integration offered by the FL7701. The result is increased luminary lifespan to more than five years (current solution only achieves three years.) And reliability is also improved since no electrolytic capacitors for the input, output or the FL7701 V_{DD} supply are required.

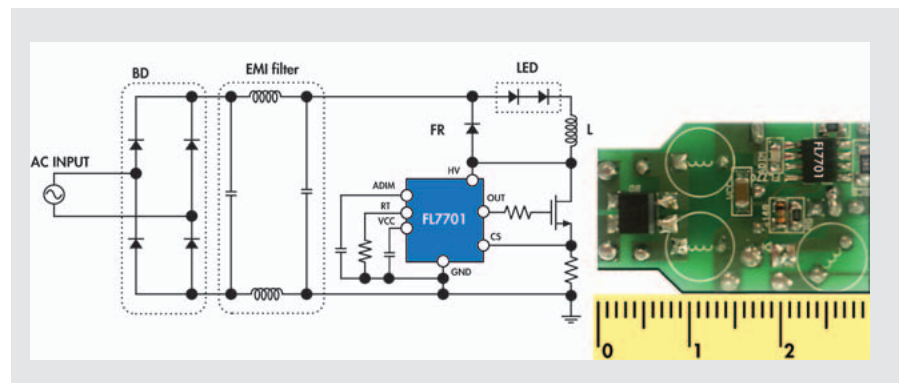

Typical application

Product Number	Topology	PFC	Dimming	CC Variance (%)	Frequency (kHz)	Package
FL7701	Non-Isolation PFC Buck	Yes	Yes	3	Variable	SOIC-8

Advantages

- **FAN302HL**
 - $\leq 8\text{mW}$ standby
 - $\leq 15\text{W}$ chargers
 - PSR for CC & SSR for CV
 - mWSaver™ Technology
- **FAN6920MR, FAN7382, FAN6204**
 - Dual-switch QR + CRM PFC + HV half-bridge driver + SR control
 - Exceeds 2013 ErP no load spec
 - mWSaver™ Technology
- **FAN6756, FAN6204**
 - PWM controller + SR controller
 - 90+% efficiency
 - $\leq 26\text{mW}$ standby
 - mWSaver™ Technology

Applications

- Adapters/converters for mobile phones and firewalls, tablets, PCs and large flat panel TVs

For more information, please visit:

www.fairchildsemi.com/pf/FA/FAN302HL.html
www.fairchildsemi.com/pf/FA/FAN6920MR.html
www.fairchildsemi.com/pf/FA/FAN7382.html
www.fairchildsemi.com/pf/FA/FAN6756.html
www.fairchildsemi.com/pf/FA/FAN6204.html
www.fairchildsemi.com/powersupplywebdesigner
www.fairchildsemi.com/flybackconverter

Engineering Connections

Power Supply WebDesigner Blog and Podcast

Save engineering time and costs with Power Supply WebDesigner—without being a power expert. Find out how in our blog, or listen to our podcast, at www.fairchildsemi.com/engineeringconnections.

Achieve Industry-Best Energy Savings for Flyback Designs

Designers using flyback topology can now achieve optimum converter performance with Fairchild's expansive portfolio of flyback controllers. Enabling power savings, achieving high-power density and meeting energy standards, the portfolio includes:

- The FAN302HL mWSaver™ Technology PWM controller, a highly integrated device that includes a proprietary burst-mode function with low operation current and minimizes standby power consumption.
- The dual switch flyback solution for 75W~230W applications and consists of the FAN6920MR integrated critical mode PFC and quasi-resonant current mode PWM controller, the FAN7382 gate driver, in tandem with the FAN6204 secondary synchronous rectifier controller for flyback topology and forward freewheeling rectification.
- The FAN6756 mWSaver™ Technology PWM controller, dramatically reduces standby and no-load power consumption, enabling conformance to worldwide standby mode efficiency guidelines.

In addition, Fairchild offers the Power Supply WebDesigner (PSW) online design and simulation tool that takes your specifications and provides a complete primary-side regulated (PSR) flyback converter or secondary-side regulated (SSR) flyback converter designs in minutes—at no expense.

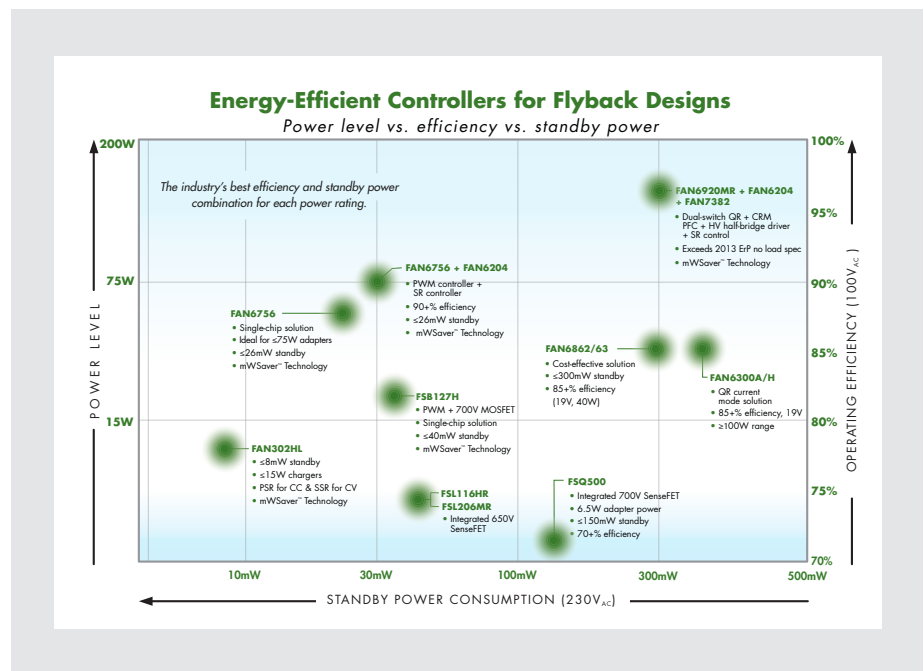

N-CHANNEL PowerTrench® MOSFET

Advantages

- Provides lower conduction losses, max $R_{SS(ON)} = 16.5\text{m}\Omega$ at $V_{GS} = 4.5\text{V}$, $I_D = 8\text{A}$
- 40% smaller than legacy solutions
- MicroFET 2mm x 3mm²
- RoHS Compliant
- HBM ESD protection >2kV

Applications

- Ultraportable applications

For more information, please visit:

www.fairchildsemi.com/pf/FD/FDMB2307NZ.html

Improve Battery Life, Reduce Space in Li-Ion Battery Pack

For mobile applications that use a one-cell Li-Ion battery pack, Fairchild's FDMB2307NZ dual N-channel PowerTrench® MOSFET, addresses design space and efficiency challenges. The device enables bidirectional current flow, and by using advanced PowerTrench processes, the FDMB2307NZ provides high power density and a maximum $R_{SS(ON)}$ of 16.5mΩ at $V_{GS} = 4.5\text{V}$, $I_D = 8\text{A}$. This results in lower conduction losses, lower voltage drop, less power dissipation and increased overall design efficiency when compared to competitive solutions.

Designers will also benefit from excellent thermal performance, resulting in cooler system operation, further increasing efficiency. The device's small package size (MicroFET 2mm x 3mm²) provides one of the smallest MLP solutions available—40% smaller than existing legacy solutions—saving significant board space in their design.

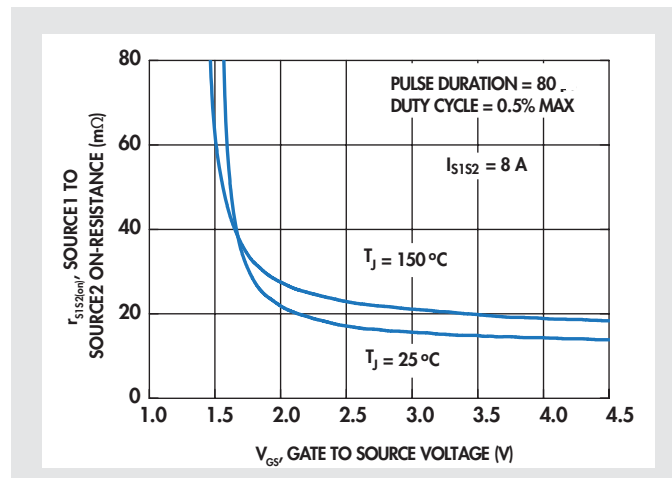

On Resistance vs. Gate to Source Voltage

Product Number	I_D max (A)	P_D max (W)	$R_{SS(ON)}$ max @ 4.5V /mΩ	$R_{SS(ON)}$ max @ 4.2V /mΩ	$R_{SS(ON)}$ max @ 3.1V /mΩ	Q_g typ nc	ESD HBM (kV)	Package (mm)
FDMB2307NZ	9.7	2.2	16.5	18	21	18	>2	2 x 3 x 0.8

Flyback Design and Simulation in Minutes

Faster power supply designs—whether you are a power supply expert or not—are now a reality with Fairchild's Power Supply WebDesigner (PSW). This online design and simulation tool takes your specifications and provides a complete Primary-Side Regulated (PSR) Flyback Converter or Secondary-Side Regulated (SSR) Flyback Converter design.

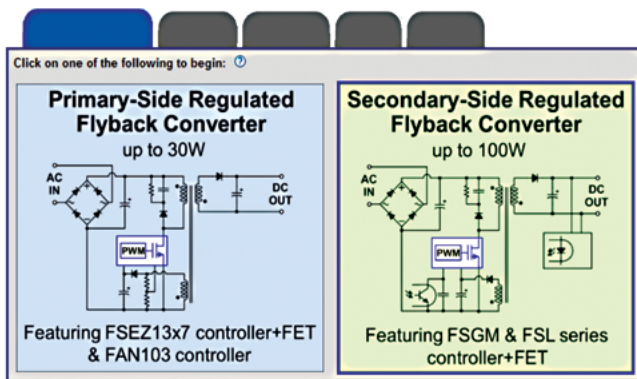

You get a schematic, simulated verification, and bill of material costs in minutes. Fine-tune design parameters without a bench prototype, swap component choices and perform detailed simulations and analyses—all with the ability to confidentially save your design for future reference.

Applications:

- SMPS for STB, DVD, DVCD players
- SMPS for home appliances, printer, scanner, facsimile, LCD monitor, LCD TV
- Battery charger for cellular phones, cordless phones, digital cameras, power tools

Power Supply WebDesigner Blog and Podcast

Save engineering time and costs with Power Supply WebDesigner—without being a power expert. Read our full blog, or listen to our podcast to learn more:

www.fairchildsemi.com/engineeringconnections.

For more information, visit:

www.fairchildsemi.com/powersupplywebdesigner.

Engineering Connections offers blogs, videos, online seminars and podcasts that help designers solve their design challenges and speed time-to-market. Get the latest information at www.fairchildsemi.com/engineeringconnections.

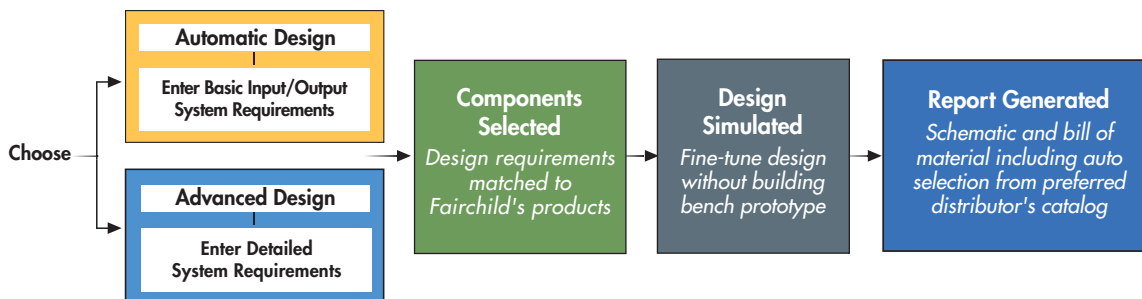

For datasheets, application notes, samples and more, please visit: www.fairchildsemi.com

PRODUCTS

APPLICATIONS

DESIGN SUPPORT

ABOUT FAIRCHILD

POWER MANAGEMENT

Power Factor Correction

- Continuous Conduction Mode (CCM) PFC Controllers
- Critical/Boundary Conduction Mode (CrCM/BCM) PFC Controllers
- Interleaved PFC Controllers
- PFC + PWM Combination (Combo) Controllers

Off-Line and Isolated DC-DC

- AC-DC Linear Regulators
- Flyback & Forward PWM Controllers
- Flyback & Forward PWM Controllers with Integrated MOSFET
- LLC Resonant & Asymmetric Half Bridge PWM Controllers
- LLC Resonant & Asymmetric Half Bridge PWM Controllers with Integrated MOSFETs
- Primary-Side Regulation CV/CC Controllers
- Primary-Side Regulation CV/CC Controllers with Integrated MOSFET
- Standard PWM Controllers
- Supervisory/Monitor ICs
- Synchronous Rectifier Controllers

Non-Isolated DC-DC

- Charge-pump Converters
- DrMOS FET plus Driver Multi-Chip Modules
- Step-down Controllers (External Switch)
- Step-down Regulators, Non-Synchronous (Integrated Switch)
- Step-down Regulators, Synchronous (Integrated Switch)
- Step-up Regulators (Integrated Switch)

MOSFET and IGBT Gate Drivers

- 3-Phase Drivers
- Half-Bridge Drivers
- High- & Low-Side Drivers
- High-Side Drivers
- Low-Side Drivers

Voltage Regulators

- LDOs
- Positive Voltage Linear Regulators
- Negative Voltage Linear Regulators
- Shunt Regulators
- Voltage Detector
- Voltage Stabilizer
- Voltage to Frequency Converter

Motion Control

- BLDC/PMSM Controller
- Motion-SPM™ (Smart Power Modules)
- PFC SPM® (Smart Power Modules)

Diodes & Rectifiers

- Bridge Rectifiers
- Circuit Protection & Transient Voltage Suppressors (TVS)
- Diacs
- Rectifiers
- Schottky Diodes & Rectifiers
- Small Signal Diodes
- Zener Diodes

IGBTs

- Discrete IGBTs
- Ignition IGBTs

MOSFETs

- Discrete MOSFETs
- Level-Shifted Load Switches
- MOSFET/Schottky Combos

Transistors

- BJTs
- Darlingtons
- Digital/Bias-Resistor Transistors
- JFETs
- RF Transistors
- Small Signal Transistors

Advanced Load Switches

- Advanced Current Limited Load Switches
- Slew Rate Controlled Load Switches

Battery Management

- Battery Charger ICs

Ground Fault Interrupt

- Ground Fault Interrupt (GFI) Controllers

Backlight Unit (BLU)

- CCFL Inverter ICs

SIGNAL PATH ICs

Amplifiers & Comparators

- Comparators
- Operational Amplifiers

Audio Amplifiers

- Audio Subsystems
- Audio Headphone Amplifiers
- Digital Microphone Amplifiers

Battery Protection ICs

- Battery Protection ICs

Interface

- LVDS
- Serializers/Deserializers (µSerDes™)
- USB Transceivers

Signal Conditioning

- Video Filter Drivers
- Video Switch Matrix/Multiplexers

Signaling, Sensing & Timing

- Signaling, Sensing & Timing
- Timing

Switches

- Accessory Switches
- Analog Switches
- Audio Jack Detection Switches
- Audio Switches
- Bus Switches
- MIPI Switches
- Multimedia Switches
- USB Switches
- Video Switches

LOGIC

Buffers, Drivers, Transceivers

- Buffers
- Line Drivers
- Transceivers

Flip Flops, Latches, Registers

- Counters
- Flip Flops
- Inverters
- Latches
- Registers

Gates

- AND Gates
- NAND Gates
- OR Gates
- NOR Gates
- Schmitt Triggers
- Configurable Gates

Multiplexer / Demultiplexer /

Decoders

- Decoders
- Demultiplexers
- Multiplexers
- Multivibrators

Voltage Level Translators

- Voltage Level Translators

LIGHTING ICs

- Fluorescent Lamp ICs
- HID ICs
- LED Lighting ICs
- Portable LED Drivers

OPTOELECTRONICS

High Performance Optocouplers

- Low Voltage, High Performance
- High Speed Logic Gate
- High Performance Transistor
- IGBT/MOSFET Gate Driver
- Specific Function

Infrared

- Emitting Diodes
- Photo Sensors
- Photo Sensor – Transistors
- Ambient Light Sensors
- Reflective Sensors
- Optical Interrupt Switches

Phototransistor Optocouplers

- Isolated Error Amplifier
- Phototransistor Output - DC Sensing Input
- Phototransistor Output - AC Sensing Input
- Photo Darlington Output

TRIAC Driver Optocouplers

- Random Phase TRIAC Driver
- Zero Crossing TRIAC Driver

AUTOMOTIVE PRODUCTS

Automotive Discrete Power

- Automotive Ignition IGBTs
- Automotive IGBTs
- Automotive N-Channel MOSFETs
- Automotive P-Channel MOSFETs
- Automotive Rectifiers

Automotive High Voltage Gate Drivers (HVICs)

- Automotive High Voltage Gate Drivers (HVICs)

High Side Smart Switches

- High Side Smart Switches