

1. SCOPE

This specification shall cover the characteristics of the ceramic resonator with the type ZTTCW24.0MX.

2. PART NO.:

PART NUMBER	CUSTOMER PART NO	SPECIFICATION NO
ZTTCW24.0MX		

3. OUTLINE DRAWING AND DIMENSIONS:

Appearance: No visible damage and dirt.

Dimensions:

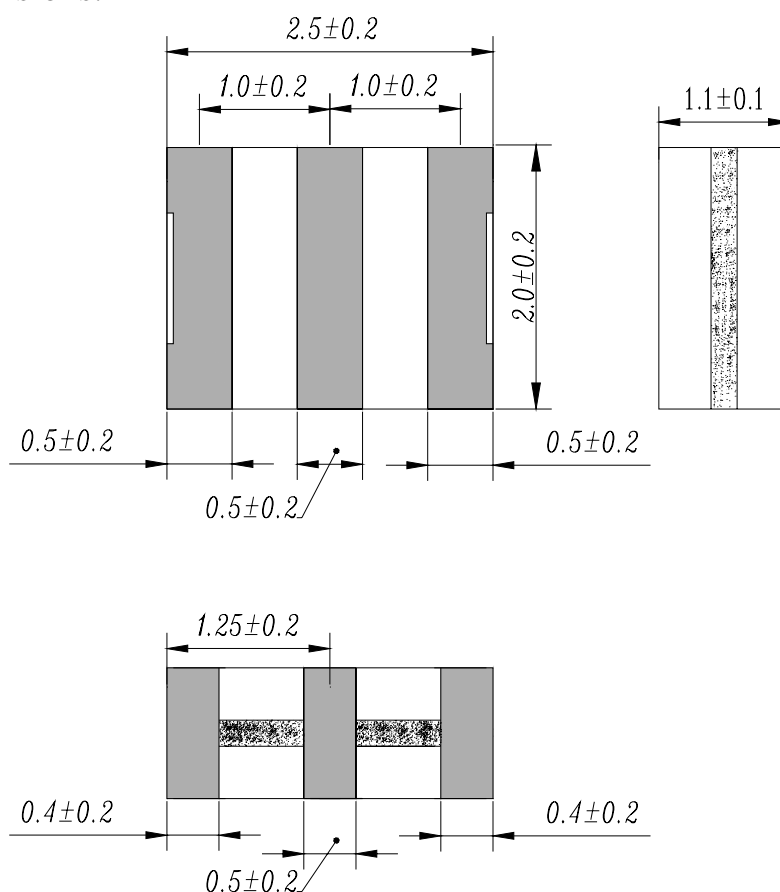

NOTES:

- 1.All dimensions are in millimeters.
- 2.Marking: A and EIAJ Monthly Code.

4. STRUCTURE

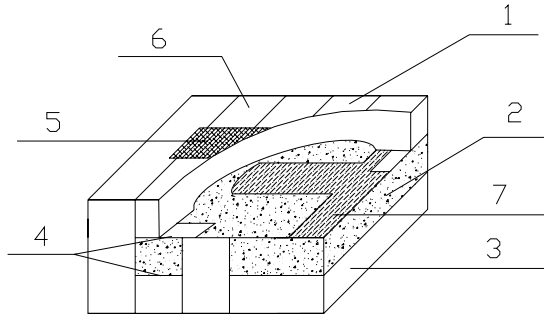

NO:	Components	Materials
1	Ceramic Substrate	Insulation Substrate
2	Ceramic Substrate	Piezoelectric Ceramics (PZT)
3	Ceramic Substrate	Insulation Substrate
4	Adhesive	Epoxy Resin
5	UV Ink for Marking	
6	Outer Electrodes	Top and Bottom Electrodes Ag+Ni(under plating)+Sn(over plating) Side Electrodes Ni+Cu+Ag(under plating)+Sn(over plating)
7	Electrode	Cu+Ag

5. ELECTRICAL SPECIFICATIONS:

No	Item	Requirements
5.1	Oscillation Frequency F_{osc} (MHz)	24.0
	Frequency Accuracy (%)	± 0.5
5.2	Resonant Impedance R_o (Ω) max	40
5.3	Temperature Coefficient of Oscillation Frequency (%) max	± 0.2 (Oscillation Frequency drift -25°C to $+85^{\circ}\text{C}$)
5.4	Withstanding Voltage	50 VDC, 1 min
5.5	Rating Voltage U_R (V) (1) D.C. Voltage (2) A.C. Voltage	6 VDC. 15 Vp-p.
5.6	Insulation Resistance R_i , ($M\Omega$) min	500
5.7	Operating Temperature ($^{\circ}\text{C}$)	$-25 \sim +85$
5.8	Storage Temperature ($^{\circ}\text{C}$)	$-55 \sim +85$
5.9	Aging Rate (%) max	± 0.2 (For 10 years)
5.10	Loop Gain (dB) min	12.0

6. MEASUREMENT:

Measurement Conditions: Parts shall be measured under a condition (Temp.: $20 \pm 15^{\circ}\text{C}$, Humidity : $65 \pm 20\%$ R.H.) unless the standard condition (Temp.: $25 \pm 3^{\circ}\text{C}$, Humidity : $65 \pm 5\%$ R.H.) is regulated to measure.

Test Circuit:

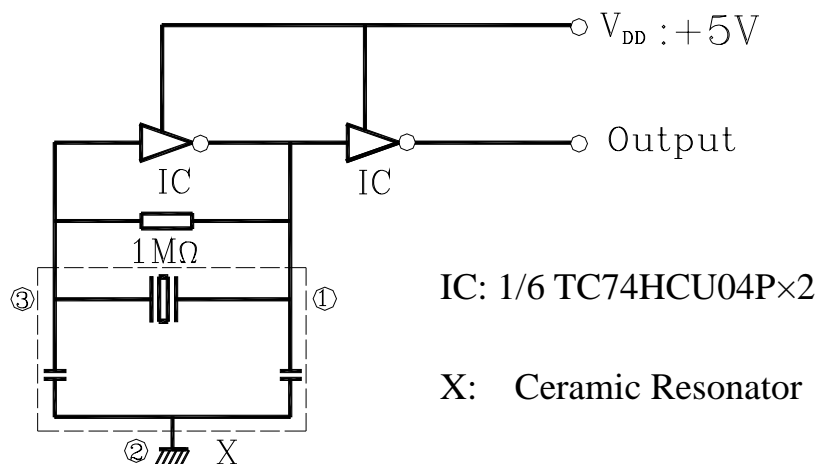

7. PHYSICAL AND ENVIRONMENTAL CHARACTERISTICS

No	Item	Condition of Test		Performance Requirements
7.1	Humidity	Keep the resonator at $60\pm 2\text{ }^{\circ}\text{C}$ and 90-95% RH for 96 ± 4 hours. Then release the resonator into the room condition for 1 hour prior to the measurement.		It shall fulfill the specifications in Table 1.
7.2	Vibration	Subject the resonator to vibration for 2 hours each in x、y and z axis with the amplitude of 1.5mm, the frequency shall be varied uniformly between the limits of 10Hz—55Hz.		It shall fulfill the specifications in Table 1.
7.3	Mechanical Shock	Drop the resonator randomly onto a wooden floor from the height of 100cm 3 times.		It shall fulfill the specifications in Table 1.
7.4	Soldering Test	Passed through the re-flow oven under the following condition and left at room temperature for 1 hour before measurement.		It shall fulfill the specifications in Table 1.
		Temperature at the surface of the substrate	Time	
		Preheat $150\pm 5\text{ }^{\circ}\text{C}$	60 ± 10 sec	
		Peak $240\pm 5\text{ }^{\circ}\text{C}$	10 ± 3 sec	
7.5	Solder Ability	Dipped in $230\pm 5\text{ }^{\circ}\text{C}$ solder bath for 3 ± 0.5 sec seconds with rosin flux 25wt% ethanol solution.	The terminals shall be at least 95% covered by solder.	
7.6	High Temperature Exposure	Subject the resonator to $85\pm 5\text{ }^{\circ}\text{C}$ for 96 ± 4 hours. Then release the resonator into the room conditions for 1 hour prior to the measurement.	It shall fulfill the specifications in Table 1.	

7. PHYSICAL AND ENVIRONMENTAL CHARACTERISTICS

(Continued from the preceding page)

No	Item	Condition of Test	Performance Requirements
7.7	Low Temperature Exposure	Subject the resonator to $-25\pm 5^{\circ}\text{C}$ for 96 ± 4 hours. Then release the resonator into the room conditions for 1 hour prior to the measurement.	It shall fulfill the specifications in Table 1.
7.8	Temperature Cycling	Subject the resonator to -40°C for 30 min. followed by a high temperature of 85°C for 30 min. cycling shall be repeated 5 times with a transfer time of 15 sec. At the room temperature for 1 hour prior to the measurement.	It shall fulfill the specifications in Table 1.
7.9	Board Bending	Mount a glass-epoxy board (Width=40mm,thickness=1.6mm), then bend it to 1mm displacement and keep It for 5 seconds. (See the following Figure)	Mechanical damage such as breaks shall not occur.

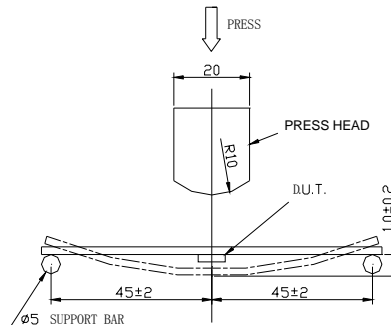

TABLE 1

Item	Specification
Oscillation Frequency Change $\Delta F_{osc}/F_{osc}$ (%) max	± 0.3
Resonant Impedance (Ω) max	60

8. REVIEW OF SPECIFICATIONS

When something gets doubtful with this specifications, we shall jointly work to get an agreement.

9. RECOMMENDED LAND PATTERN AND REFLOW SOLDERING

STANDARD CONDITIONS

a) Recommended land pattern

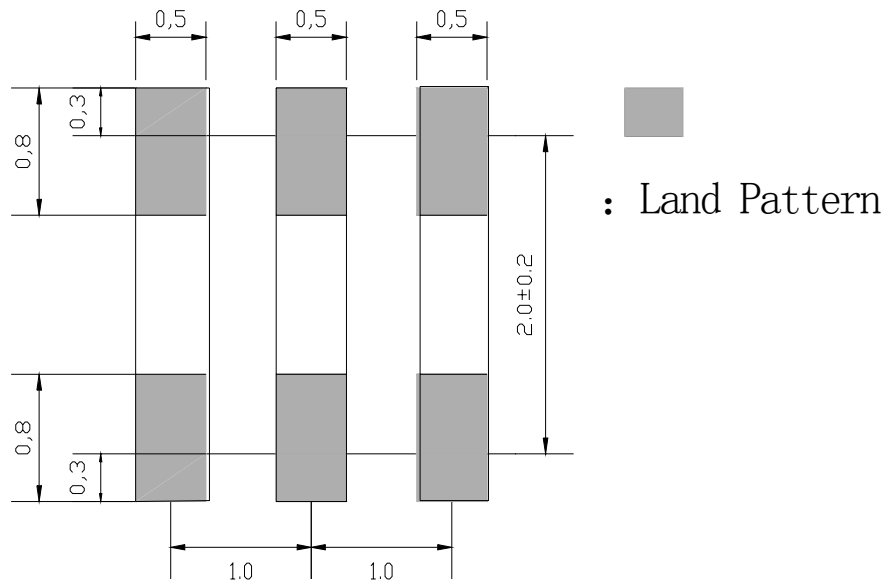

b) Recommended reflow soldering standard conditions

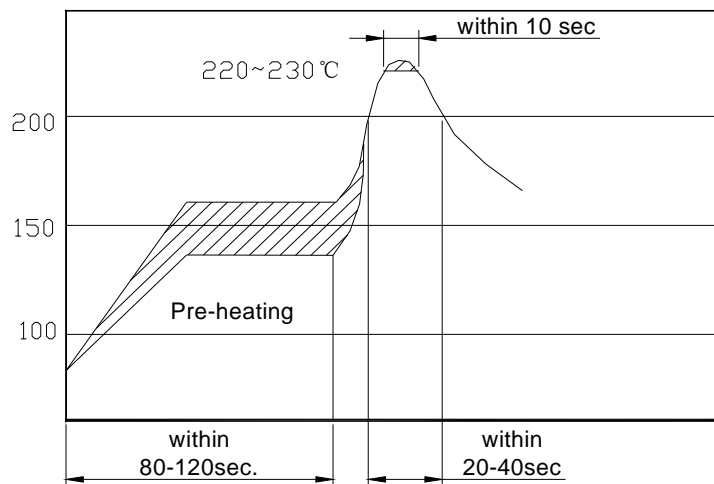

10. PACKAGE

To protect the products in storage and transportation, it is necessary to pack them (outer and inner package). On paper pack, the following requirements are requested.

SHENZHEN LUGUANG ELECTRONIC TECHNOLOGY CO.,LTD.

a) Dimensions and Mark

At the end of package, the warning (moisture proof, upward put) should be stick to it.

Dimensions and Mark (see below)

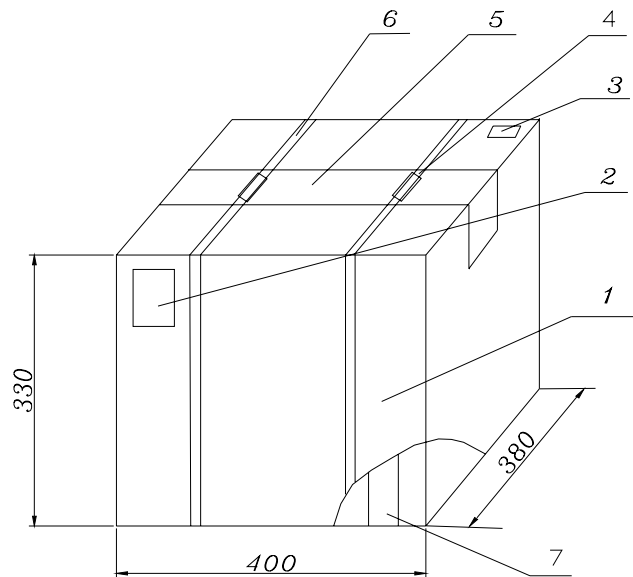

NO.	Name	Quantity	Notes
1	Package	1	
2	Certificate of approval	1	
3	Label	1	
4	Tying	2	
5	Adhesive tape	1.2m	
6	Belt	2.9m	
7	Inner Box	10	

b) Section of package

Package is made of corrugated paper with thickness of 0.8cm. Package has 12 inner boxes, each box has 6 reels (each reel for plastic bag).



c) Quantity of package

- Per plastic reel 3000 pieces of piezoelectric ceramic part
- Per inner box 6 reels
- Per package 12 inner boxes (216000 pieces of piezoelectric ceramic part)

d) Inner Packing Dimensions

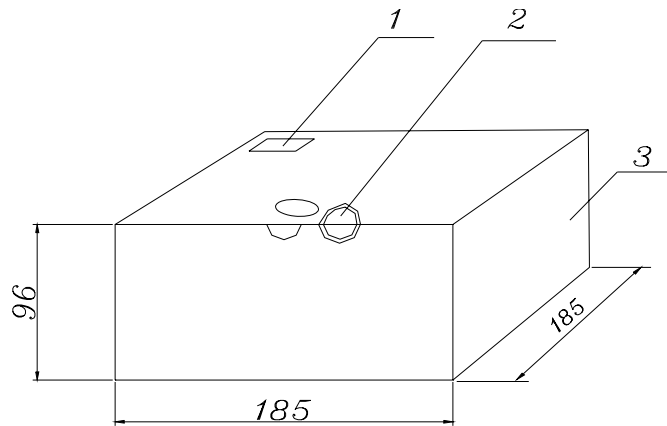

1	Label
2	QC Label
3	Inner Box

UNIT: mm

Pars shall be packaged in box with hold down tape upside. Part No., quantity and lot No.

e) Reel

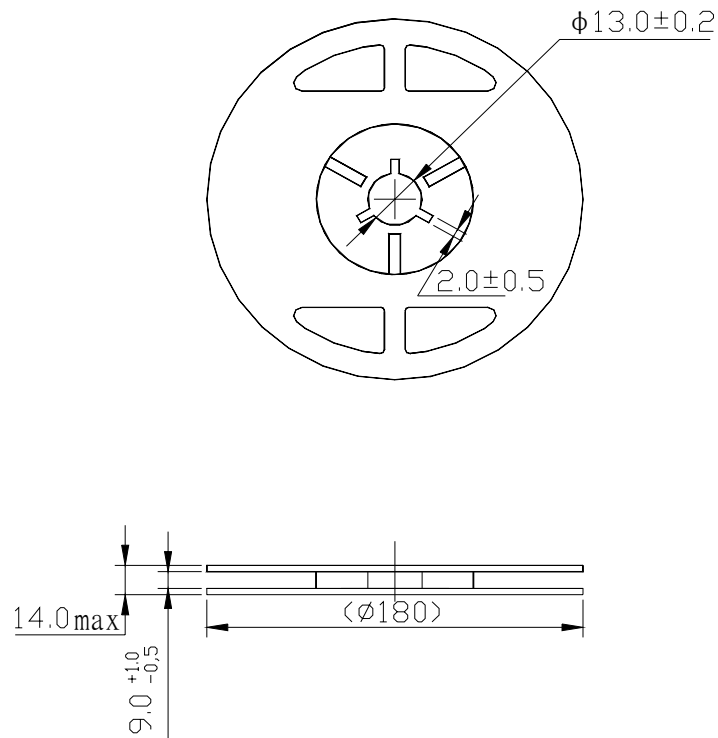

f) Packing Method Sketch Map

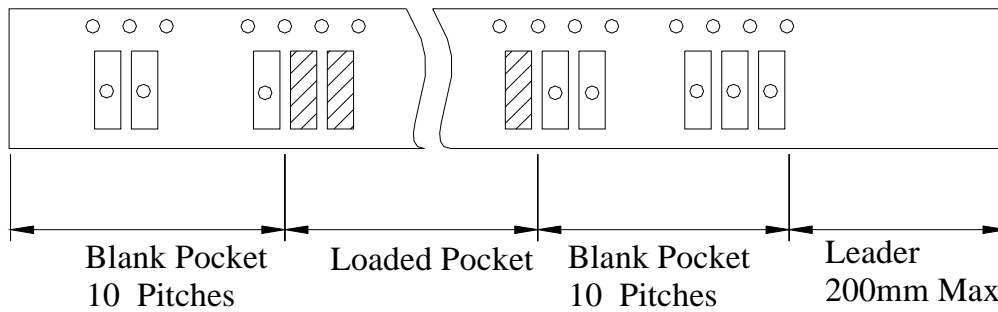

g) Test Condition Of Peeling Strength

