

3 Phase bridge NPT IGBT Power Module

$V_{CES} = 1200V$
 $I_C = 50A @ T_c = 80^\circ C$

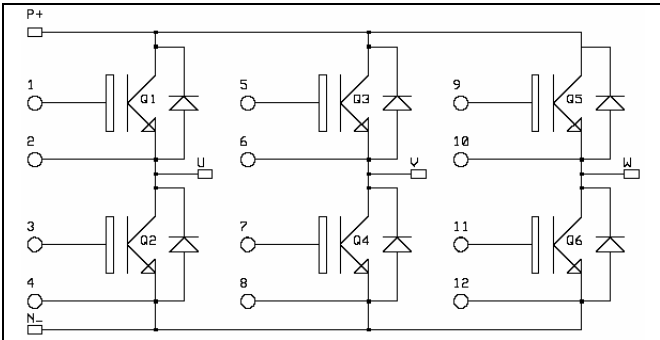

Application

- AC Motor control

Features

- Non Punch Through (NPT) IGBT®
 - Low voltage drop
 - Low tail current
 - Switching frequency up to 20 kHz
 - Soft recovery parallel diodes
 - Low diode VF
 - Low leakage current
 - Avalanche energy rated
 - RBSOA and SCSOA rated
- Kelvin emitter for easy drive
- Very low stray inductance
- High level of integration

Pin out: APTGF50X120E2 (Long pins)

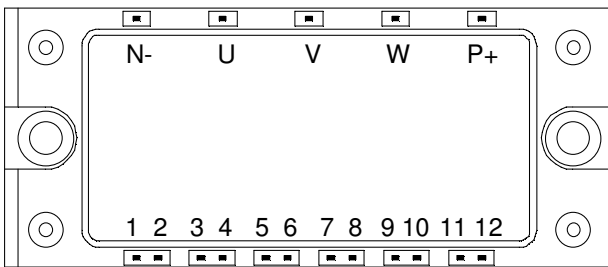

Pin out: APTGF50X120P2 (Short pins)

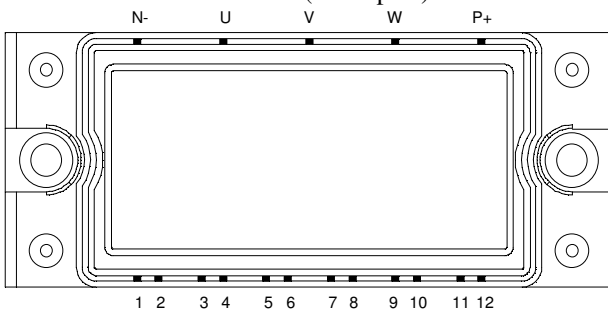

Benefits

- Stable temperature behavior
- Very rugged
- Solderable terminals for easy PCB mounting
- Direct mounting to heatsink (isolated package)
- Low junction to case thermal resistance
- Easy paralleling due to positive TC of VCEsat
- Low profile

All ratings @ $T_j = 25^\circ C$ unless otherwise specified

Absolute maximum ratings

Symbol	Parameter	Max ratings	Unit
V_{CES}	Collector - Emitter Breakdown Voltage	1200	V
I_C	Continuous Collector Current	$T_C = 25^\circ C$	72
		$T_C = 80^\circ C$	50
I_{CM}	Pulsed Collector Current	$T_C = 25^\circ C$	140
V_{GE}	Gate - Emitter Voltage	± 20	V
P_D	Maximum Power Dissipation	$T_C = 25^\circ C$	350
SCSOA	Short Circuit Safe Operating Area	$T_j = 125^\circ C$	500A@1200V

CAUTION: These Devices are sensitive to Electrostatic Discharge. Proper Handling Procedures Should Be Followed.

Electrical Characteristics

<i>Symbol</i>	<i>Characteristic</i>	<i>Test Conditions</i>	<i>Min</i>	<i>Typ</i>	<i>Max</i>	<i>Unit</i>
BV _{CES}	Collector - Emitter Breakdown Voltage	V _{GE} = 0V, I _C = 500μA	1200			V
I _{CES}	Zero Gate Voltage Collector Current	V _{GE} = 0V V _{CE} = 1200V		T _J = 25°C 0.8 T _J = 125°C 4	1	mA
V _{CE(on)}	Collector Emitter on Voltage	V _{GE} = 15V I _C = 50A		T _J = 25°C 2.5 T _J = 125°C 3.1	3.0 3.7	V
V _{GE(th)}	Gate Threshold Voltage	V _{GE} = V _{CE} , I _C = 2 mA	4.5	5.5	6.5	V
I _{GES}	Gate - Emitter Leakage Current	V _{GE} = 20V, V _{CE} = 0V			200	nA

Dynamic Characteristics

<i>Symbol</i>	<i>Characteristic</i>	<i>Test Conditions</i>	<i>Min</i>	<i>Typ</i>	<i>Max</i>	<i>Unit</i>
C _{ies}	Input Capacitance	V _{GE} = 0V		3300		pF
C _{oes}	Output Capacitance	V _{CE} = 25V		500		
C _{res}	Reverse Transfer Capacitance	f = 1MHz		220		
T _{d(on)}	Turn-on Delay Time	Inductive Switching (125°C) V _{GE} = ±15V V _{Bus} = 600V I _C = 50A R _G = 22Ω		44	100	ns
T _r	Rise Time			56	100	
T _{d(off)}	Turn-off Delay Time			380	500	
T _f	Fall Time			70	100	

Reverse diode ratings and characteristics

<i>Symbol</i>	<i>Characteristic</i>	<i>Test Conditions</i>	<i>Min</i>	<i>Typ</i>	<i>Max</i>	<i>Unit</i>
V _F	Diode Forward Voltage	I _F = 50A V _{GE} = 0V		T _J = 25°C 2.3 T _J = 125°C 1.8	2.8	V
t _{rr}	Reverse Recovery Time	I _F = 50A V _R = 600V di/dt = 800A/μs		T _J = 125°C 0.2		μs
Q _{rr}	Reverse Recovery Charge	I _F = 50A V _R = 600V di/dt = 800A/μs		T _J = 25°C 2.8 T _J = 125°C 8		μC

Thermal and package characteristics

<i>Symbol</i>	<i>Characteristic</i>	<i>Min</i>	<i>Typ</i>	<i>Max</i>	<i>Unit</i>	
R _{thJC}	Junction to Case	IGBT			0.35	°C/W
		Diode			0.7	
V _{ISOL}	RMS Isolation Voltage, any terminal to case t = 1 min, I _{isol} < 1mA, 50/60Hz	2500			V	
T _J	Operating junction temperature range	-40		150	°C	
T _{STG}	Storage Temperature Range	-40		125		
T _C	Operating Case Temperature	-40		125		
Torque	Mounting torque	To Heatsink	M5	2	3.5	N.m
Wt	Package Weight				185	g

Package outline

Pin out: APTGF50X120E2 (Long pins)

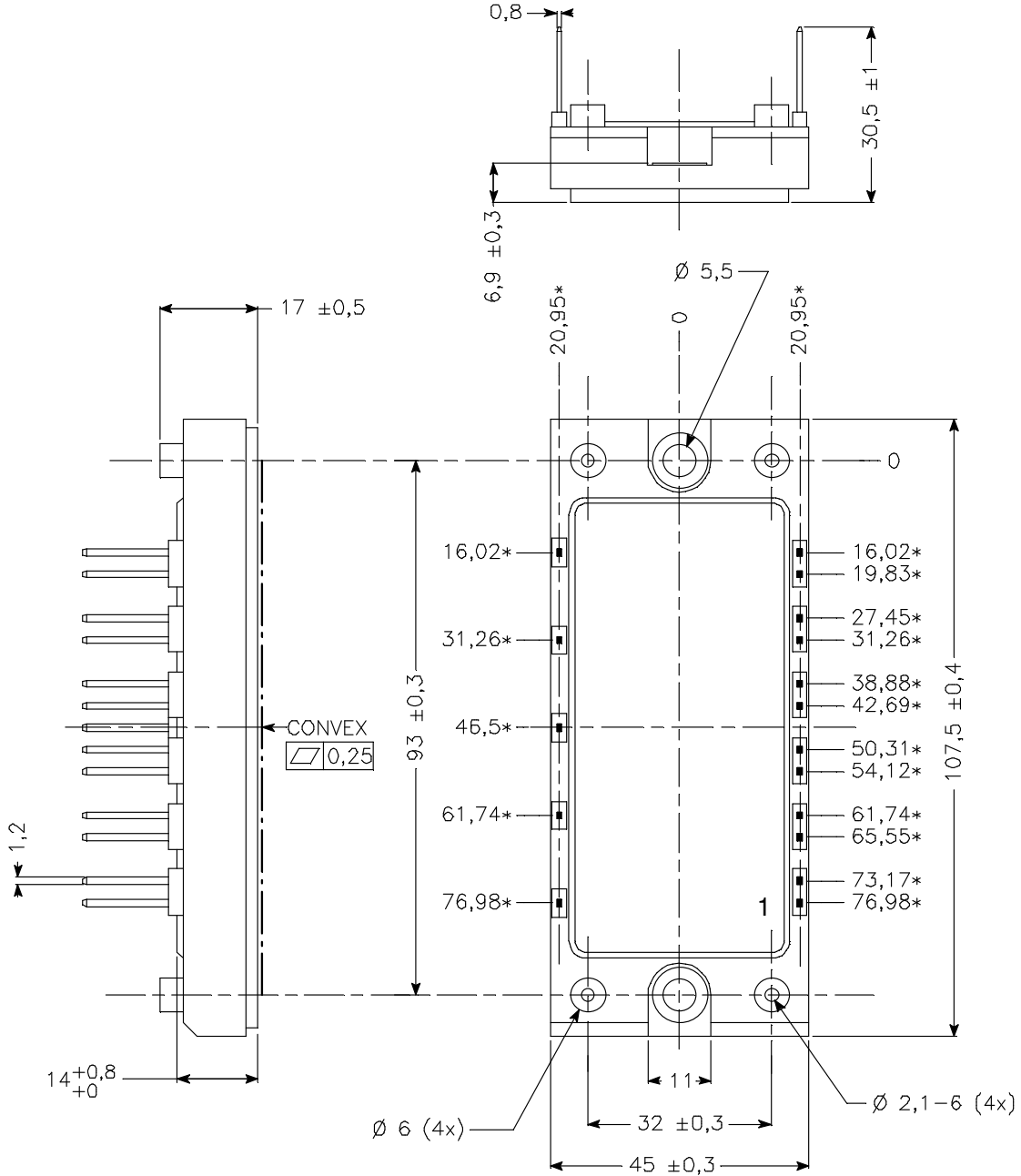

ALL DIMENSIONS MARKED "*" ARE TOLERANCED AS : $\oplus \ominus \varnothing 0,4$

Package outline

Pin out: APTGF50X120P2 (Short pins)

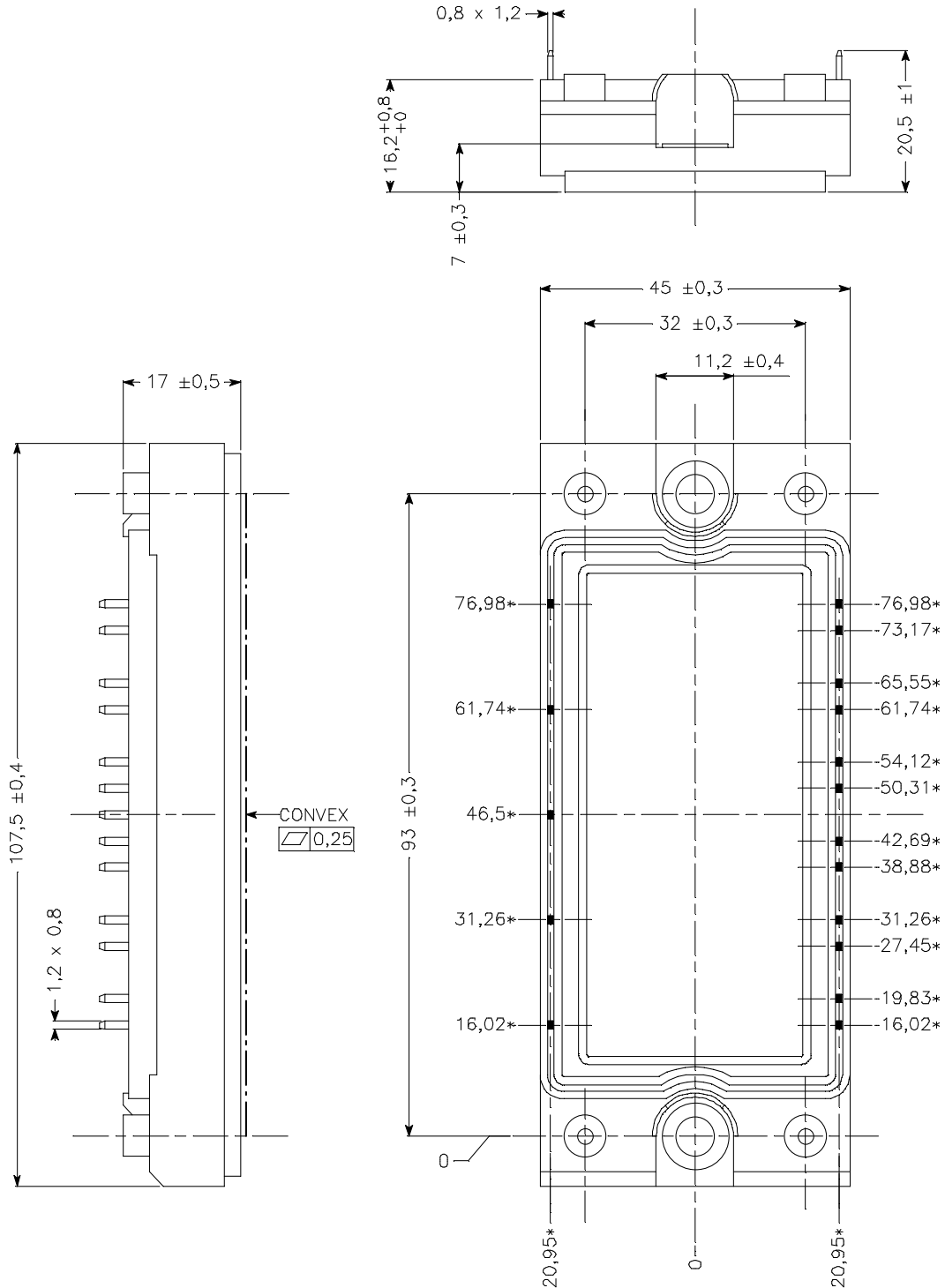

ALL DIMENSIONS MARKED "*" ARE TOLERENCED AS : $\oplus \ominus \varnothing 0,4$

APT reserves the right to change, without notice, the specifications and information contained herein

APT's products are covered by one or more of U.S patents 4,895,810 5,045,903 5,089,434 5,182,234 5,019,522 5,262,336 6,503,786 5,256,583 4,748,103 5,283,202 5,231,474 5,434,095 5,528,058 and foreign patents. U.S and Foreign patents pending. All Rights Reserved.