

**REVISIONS**

LTR	DESCRIPTION	DATE (YR-MO-DA)	APPROVED

REV																		
SHEET																		
REV																		
SHEET	15	16	17	18														
REV STATUS OF SHEETS	REV																	
	SHEET	1	2	3	4	5	6	7	8	9	10	11	12	13	14			

<b>PMIC N/A</b>	PREPARED BY Thanh V. Nguyen	<b>DEFENSE ELECTRONICS SUPPLY CENTER</b> DAYTON, OHIO 45444
<b>STANDARDIZED MILITARY DRAWING</b>  THIS DRAWING IS AVAILABLE FOR USE BY ALL DEPARTMENTS AND AGENCIES OF THE DEPARTMENT OF DEFENSE  AMSC N/A	CHECKED BY Thanh V. Nguyen	<b>MICROCIRCUIT, DIGITAL, ADVANCED BIPOLAR CMOS, 16-BIT TRANSPARENT D-TYPE LATCH WITH THREE-STATE OUTPUTS, TTL COMPATIBLE INPUTS, MONOLITHIC SILICON</b>
	APPROVED BY Monica L. Poelking	
	DRAWING APPROVAL DATE 94-04-26	
	REVISION LEVEL	
	SIZE <b>A</b>	CAGE CODE <b>67268</b>
	SHEET 1	OF 18
		<b>5962-93200</b>

DESC FORM 193  
JUL 91

5962-E235-94

DISTRIBUTION STATEMENT A. Approved for public release; distribution is unlimited.

■ 9004708 0006915 614 ■

1. SCOPE

1.1 Scope. This drawing forms a part of a one part - one part number documentation system (see 6.6 herein). Two product assurance classes consisting of military high reliability (device classes Q and M) and space application (device class V), and a choice of case outlines and lead finishes are available and are reflected in the Part or Identifying Number (PIN). Device class M microcircuits represent non-JAN class B microcircuits in accordance with 1.2.1 of MIL-STD-883, "Provisions for the use of MIL-STD-883 in conjunction with compliant non-JAN devices". When available, a choice of Radiation Hardness Assurance (RHA) Levels are reflected in the PIN.

1.2 PIN. The PIN shall be as shown in the following example:

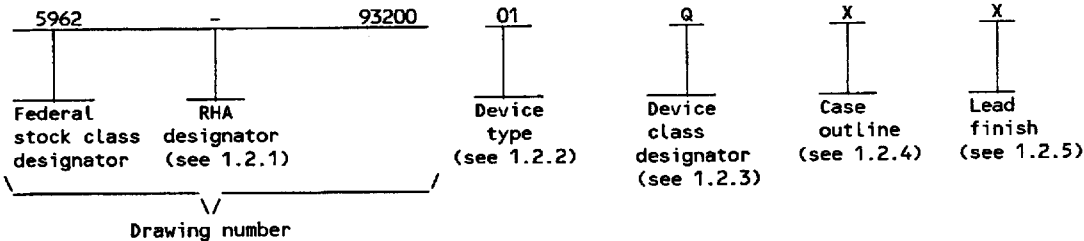

1.2.1 RHA designator. Device class M RHA marked devices shall meet the MIL-I-38535 appendix A specified RHA levels and shall be marked with the appropriate RHA designator. Device classes Q and V RHA marked devices shall meet the MIL-I-38535 specified RHA levels and shall be marked with the appropriate RHA designator. A dash (-) indicates a non-RHA device.

1.2.2 Device type(s). The device type(s) shall identify the circuit function as follows:

<u>Device type</u>	<u>Generic number</u>	<u>Circuit function</u>
01	54ABT16373A	16-bit transparent D-type latch with three-state outputs, TTL compatible inputs

1.2.3 Device class designator. The device class designator shall be a single letter identifying the product assurance level as follows:

<u>Device class</u>	<u>Device requirements documentation</u>
M	Vendor self-certification to the requirements for non-JAN class B microcircuits in accordance with 1.2.1 of MIL-STD-883
Q or V	Certification and qualification to MIL-I-38535

1.2.4 Case outline(s). The case outline(s) shall be as designated in MIL-STD-1835, and as follows:

<u>Outline letter</u>	<u>Descriptive designator</u>	<u>Terminals</u>	<u>Package style</u>
X	GDFP1-F48	48	Flat pack

1.2.5 Lead finish. The lead finish shall be as specified in MIL-STD-883 (see 3.1 herein) for class M or MIL-I-38535 for classes Q and V. Finish letter "X" shall not be marked on the microcircuit or its packaging. The "X" designation is for use in specifications when lead finishes A, B, and C are considered acceptable and interchangeable without preference.

<b>STANDARDIZED MILITARY DRAWING DEFENSE ELECTRONICS SUPPLY CENTER DAYTON, OHIO 45444</b>	<b>SIZE A</b>		<b>5962-93200</b>
		<b>REVISION LEVEL</b>	<b>SHEET 2</b>

DESC FORM 193A  
JUL 91

9004708 0006916 550

1.3 Absolute maximum ratings. 1/ 2/ 3/

Supply voltage range ( $V_{CC}$ )	-0.5 V dc to +7.0 V dc
DC input voltage range ( $V_{IN}$ )	-0.5 V dc to +7.0 V dc 4/
DC output voltage range ( $V_{OUT}$ )	-0.5 V dc to +5.5 V dc 4/
DC output current ( $I_{OL}$ ) (per output)	+96 mA
DC input clamp current ( $I_{IK}$ ) ( $V_{IN} < 0.0$ V)	-18 mA
DC output clamp current ( $I_{OK}$ ) ( $V_{OUT} < 0.0$ V)	-50 mA
$V_{CC}$ current ( $I_{VCC}$ )	514 mA
Ground current ( $I_{GND}$ )	1091 mA
Storage temperature range ( $T_{STG}$ )	-65°C to +150°C
Lead temperature (soldering, 10 seconds)	+300°C
Thermal resistance, junction-to-case ( $\theta_{JC}$ )	See MIL-STD-1835
Junction temperature ( $T_J$ )	+175°C
Maximum power dissipation ( $P_D$ )	890 mW 5/

1.4 Recommended operating conditions. 2/ 3/

Supply voltage range ( $V_{CC}$ )	+4.5 V dc to +5.5 V dc
Input voltage range ( $V_{IN}$ )	+0.0 V dc to $V_{CC}$
Output voltage range ( $V_{OUT}$ )	+0.0 V dc to $V_{CC}$
Maximum low level input voltage ( $V_{IL}$ )	0.8 V
Minimum high level input voltage ( $V_{IH}$ )	2.0 V
Maximum high level output current ( $I_{OH}$ )	-24 mA
Maximum low level output current ( $I_{OL}$ )	+48 mA
Maximum input rise or fall rate ( $\Delta t/\Delta V$ )	10 ns/V
Case operating temperature range ( $T_C$ )	-55°C to +125°C

1.5 Digital logic testing for device classes Q and V.

Fault coverage measurement of manufacturing logic tests (MIL-STD-883, test method 5012) - - - - - XX percent 6/

2. APPLICABLE DOCUMENTS

2.1 Government specification, standards, bulletin, and handbook. Unless otherwise specified, the following specification, standards, bulletin, and handbook of the issue listed in that issue of the Department of Defense Index of Specifications and Standards specified in the solicitation, form a part of this drawing to the extent specified herein.

- 1/ Stresses above the absolute maximum rating may cause permanent damage to the device. Extended operation at the maximum levels may degrade performance and affect reliability.
- 2/ Unless otherwise noted, all voltages are referenced to GND.
- 3/ The limits for the parameters specified herein shall apply over the full specified  $V_{CC}$  range and case temperature range of -55°C to +125°C.
- 4/ The input negative voltage rating may be exceeded provided that the input clamp current rating is observed.
- 5/ Power dissipation values are derived using the formula  $P_D = V_{CC}I_{VCC} + nV_{OL}I_{OL}$ , where  $V_{CC}$  and  $I_{OL}$  are as specified in 1.4 above,  $I_{VCC}$  and  $V_{OL}$  are as specified in table I herein, and n represents the total number of outputs.
- 6/ Values will be added when they become available.

STANDARDIZED MILITARY DRAWING DEFENSE ELECTRONICS SUPPLY CENTER DAYTON, OHIO 45444	SIZE A		5962-93200
		REVISION LEVEL	SHEET 3

DESC FORM 193A  
JUL 91

9004708 0006917 497

**SPECIFICATION**

**MILITARY**

MIL-I-38535 - Integrated Circuits, Manufacturing, General Specification for.

**STANDARDS**

**MILITARY**

MIL-STD-883 - Test Methods and Procedures for Microelectronics.  
MIL-STD-973 - Configuration Management.  
MIL-STD-1835 - Microcircuit Case Outlines

**BULLETIN**

**MILITARY**

MIL-BUL-103 - List of Standardized Military Drawings (SMD's).

**HANDBOOK**

**MILITARY**

MIL-HDBK-780 - Standardized Military Drawings.

(Copies of the specification, standards, bulletin, and handbook required by manufacturers in connection with specific acquisition functions should be obtained from the contracting activity or as directed by the contracting activity.)

2.3 Order of precedence. In the event of a conflict between the text of this drawing and the references cited herein, the text of this drawing shall take precedence.

**3. REQUIREMENTS**

3.1 Item requirements. The individual item requirements for device class M shall be in accordance with 1.2.1 of MIL-STD-883, "Provisions for the use of MIL-STD-883 in conjunction with compliant non-JAN devices" and as specified herein. The individual item requirements for device classes Q and V shall be in accordance with MIL-I-38535, the device manufacturer's Quality Management (QM) plan, and as specified herein.

3.2 Design, construction, and physical dimensions. The design, construction, and physical dimensions shall be as specified in MIL-STD-883 (see 3.1 herein) for device class M and MIL-I-38535 for device classes Q and V and herein.

3.2.1 Case outline. The case outline shall be in accordance with 1.2.4 herein.

3.2.2 Terminal connections. The terminal connections shall be as specified on figure 1.

3.2.3 Truth table. The truth table shall be as specified on figure 2.

3.2.4 Logic diagram. The logic diagram shall be as specified on figure 3.

3.2.5 Ground bounce load circuit and waveforms. The ground bounce load circuit and waveforms shall be as specified on figure 4.

3.2.6 Switching waveforms and test circuit. The switching waveforms and test circuit shall be as specified on figure 5.

3.3 Electrical performance characteristics and postirradiation parameter limits. Unless otherwise specified herein, the electrical performance characteristics and postirradiation parameter limits are as specified in table I and shall apply over the full case operating temperature range. Test conditions for these specified characteristics and limits are as specified in table I.

3.4 Electrical test requirements. The electrical test requirements shall be the subgroups specified in table II. The electrical tests for each subgroup are defined in table I.

<b>STANDARDIZED MILITARY DRAWING DEFENSE ELECTRONICS SUPPLY CENTER DAYTON, OHIO 45444</b>	<b>SIZE A</b>		<b>5962-93200</b>
		<b>REVISION LEVEL</b>	<b>SHEET 4</b>

DESC FORM 193A  
JUL 91

9004708 0006918 323

3.5 Marking. The part shall be marked with the PIN listed in 1.2 herein. Marking for device class M shall be in accordance with MIL-STD-883 (see 3.1 herein). In addition, the manufacturer's PIN may also be marked as listed in MIL-BUL-103. Marking for device classes Q and V shall be in accordance with MIL-I-38535.

3.5.1 Certification/compliance mark. The compliance mark for device class M shall be a "C" as required in MIL-STD-883 (see 3.1 herein). The certification mark for device classes Q and V shall be a "QML" or "Q" as required in MIL-I-38535.

3.6 Certificate of compliance. For device class M, a certificate of compliance shall be required from a manufacturer in order to be listed as an approved source of supply in MIL-BUL-103 (see 6.7.2 herein). For device classes Q and V, a certificate of compliance shall be required from a QML-38535 listed manufacturer in order to supply to the requirements of this drawing (see 6.7.1 herein). The certificate of compliance submitted to DESC-EC prior to listing as an approved source of supply for this drawing shall affirm that the manufacturer's product meets, for device class M the requirements of MIL-STD-883 (see 3.1 herein), or for device classes Q and V, the requirements of MIL-I-38535 and the requirements herein.

3.7 Certificate of conformance. A certificate of conformance as required for device class M in MIL-STD-883 (see 3.1 herein) or for device classes Q and V in MIL-I-38535 shall be provided with each lot of microcircuits delivered to this drawing.

3.8 Notification of change for device class M. For device class M, notification to DESC-EC of change of product (see 6.2 herein) involving devices acquired to this drawing is required for any change as defined in MIL-STD-973.

3.9 Verification and review for device class M. For device class M, DESC, DESC's agent, and the acquiring activity retain the option to review the manufacturer's facility and applicable required documentation. Offshore documentation shall be made available onshore at the option of the reviewer.

3.10 Microcircuit group assignment for device class M. Device class M devices covered by this drawing shall be in microcircuit group number 127 (see MIL-I-38535, appendix A).

#### 4. QUALITY ASSURANCE PROVISIONS

4.1 Sampling and inspection. For device class M, sampling and inspection procedures shall be in accordance with MIL-STD-883 (see 3.1 herein). For device classes Q and V, sampling and inspection procedures shall be in accordance with MIL-I-38535 and the device manufacturer's QM plan.

4.2 Screening. For device class M, screening shall be in accordance with method 5004 of MIL-STD-883, and shall be conducted on all devices prior to quality conformance inspection. For device classes Q and V, screening shall be in accordance with MIL-I-38535, and shall be conducted on all devices prior to qualification and technology conformance inspection.

##### 4.2.1 Additional criteria for device class M.

a. Burn-in test, method 1015 of MIL-STD-883.

(1) Test condition A, B, C or D. The test circuit shall be maintained by the manufacturer under document revision level control and shall be made available to the preparing or acquiring activity upon request. The test circuit shall specify the inputs, outputs, biases, and power dissipation, as applicable, in accordance with the intent specified in test method 1015.

(2)  $T_A = +125^\circ\text{C}$ , minimum.

b. Interim and final electrical test parameters shall be as specified in table II herein.

<b>STANDARDIZED MILITARY DRAWING DEFENSE ELECTRONICS SUPPLY CENTER DAYTON, OHIO 45444</b>	<b>SIZE A</b>		<b>5962-93200</b>
		<b>REVISION LEVEL</b>	<b>SHEET 5</b>

DESC FORM 193A  
JUL 91

9004708 0006919 267

TABLE I. Electrical performance characteristics.

Test and MIL-STD-883 test method <u>1/</u>	Symbol	Test conditions <u>2/</u> -55°C ≤ T <sub>C</sub> ≤ +125°C +4.5 V ≤ V <sub>CC</sub> ≤ +5.5 V unless otherwise specified	V <sub>CC</sub>	Group A subgroups	Limits <u>3/</u>		Unit
					Min	Max	
High level output voltage 3006	V <sub>OH</sub>	For all inputs affecting output under test V <sub>IN</sub> = 2.0 V or 0.8 V	I <sub>OH</sub> = -3.0 mA	4.5 V	1, 2, 3	2.5	V
				5.0 V	1, 2, 3	3.0	
			I <sub>OH</sub> = -24.0 mA	4.5 V	1, 2, 3	2.0	
Low level output voltage 3007	V <sub>OL</sub>	For all inputs affecting output under test, V <sub>IN</sub> = 2.0 V or 0.8 V I <sub>OL</sub> = 48 mA	4.5 V	1, 2, 3		0.55	V
Negative input clamp voltage 3022	V <sub>IC-</sub>	For input under test, I <sub>IN</sub> = -18 mA	4.5 V	1, 2, 3		-1.2	V
Input current high 3010	I <sub>IH</sub>	For input under test, V <sub>IN</sub> = V <sub>CC</sub>	5.5 V	1, 2, 3		1.0	μA
Input current low 3009	I <sub>IL</sub>	For input under test, V <sub>IN</sub> = GND	5.5 V	1, 2, 3		-1.0	μA
Three-state output leakage current high 3021	I <sub>OZH</sub>	For control input affecting output under test, V <sub>IN</sub> = 2.0 V or 0.8 V V <sub>OUT</sub> = 2.7 V	5.5 V	1, 2, 3		10	μA
Three-state output leakage current low 3020	I <sub>OZL</sub>	For control input affecting output under test, V <sub>IN</sub> = 2.0 V or 0.8 V V <sub>OUT</sub> = 0.5 V	5.5 V	1, 2, 3		-10	μA
Off-state leakage current	I <sub>OFF</sub>	For input or output under test V <sub>IN</sub> or V <sub>OUT</sub> = 4.5 V All other pins at 0.0 V	0.0 V	1		±100	μA
High-state leakage current	I <sub>CEX</sub>	For output under test, V <sub>OUT</sub> = 5.5 V Outputs at high logic state	5.5 V	1, 2, 3		50	μA
Output current 3011	I <sub>O</sub> <u>4/</u>	V <sub>OUT</sub> = 2.5 V	5.5 V	1, 2, 3	-50	-180	mA
Quiescent supply current delta, TTL input level 3005	ΔI <sub>CC</sub> <u>5/</u>	For input under test, V <sub>IN</sub> = 3.4 V For all other inputs, V <sub>IN</sub> = V <sub>CC</sub> or GND	5.5 V	1, 2, 3		1.5	mA

See footnotes at end of table.

<b>STANDARDIZED MILITARY DRAWING DEFENSE ELECTRONICS SUPPLY CENTER DAYTON, OHIO 45444</b>	<b>SIZE A</b>		<b>5962-93200</b>
		<b>REVISION LEVEL</b>	<b>SHEET 6</b>

DESC FORM 193A  
JUL 91

■ 9004708 0006920 T81 ■

TABLE I. Electrical performance characteristics - Continued.

Test and MIL-STD-883 test method <u>1/</u>	Symbol	Test conditions <u>2/</u> -55°C ≤ T <sub>C</sub> ≤ +125°C +4.5 V ≤ V <sub>CC</sub> ≤ +5.5 V unless otherwise specified	V <sub>CC</sub>	Group A subgroups	Limits <u>3/</u>		Unit
					Min	Max	
Quiescent supply current, outputs high 3005	I <sub>CCH</sub>	For all inputs, V <sub>IN</sub> = V <sub>CC</sub> or GND I <sub>OUT</sub> = 0 A	5.5 V	1, 2, 3		2.0	mA
Quiescent supply current, outputs low 3005	I <sub>CCL</sub>		5.5 V	1, 2, 3		85.0	mA
Quiescent supply current, outputs disabled 3005	I <sub>CCZ</sub>		5.5 V	1, 2, 3		2.0	mA
Input capacitance 3012	C <sub>IN</sub>	T <sub>C</sub> = +25°C See 4.4.1b	5.0 V	4		10.5	pF
Output capacitance 3012	C <sub>OUT</sub>		5.0 V	4		14.5	pF
Low level ground bounce noise	V <sub>OLP</sub> <u>6/</u>	V <sub>IH</sub> = 3.0 V, V <sub>IL</sub> = 0.0 V T <sub>A</sub> = +25°C See figure 4 See 4.4.1d	5.0 V	4		600	mV
	V <sub>OLV</sub> <u>6/</u>		5.0 V	4		-1040	
High Level V <sub>CC</sub> bounce noise	V <sub>OHP</sub> <u>6/</u>		5.0 V	4		680	mV
	V <sub>OHV</sub> <u>6/</u>		5.0 V	4		-420	
Functional test 3014	<u>7/</u>	V <sub>IH</sub> = 2.0 V, V <sub>IL</sub> = 0.8 V Verify output V <sub>O</sub> See 4.4.1c	4.5 V	7, 8	L	H	
			5.5 V	7, 8	L	H	
Propagation delay time, mDn to mQn 3003	t <sub>PLH1</sub> <u>8/</u>		5.0 V	9	1.4	5.3	ns
			4.5 V and 5.5 V	10, 11	1.4	6.5	
	t <sub>PHL1</sub> <u>8/</u>	5.0 V	9	2.0	5.4	ns	
		4.5 V and 5.5 V	10, 11	2.0	6.5		

See footnotes at end of table.

<b>STANDARDIZED MILITARY DRAWING DEFENSE ELECTRONICS SUPPLY CENTER DAYTON, OHIO 45444</b>	<b>SIZE A</b>		<b>5962-93200</b>
		REVISION LEVEL	SHEET 7

DESC FORM 193A  
JUL 91

9004708 0006921 918

TABLE I. Electrical performance characteristics - Continued.

Test and MIL-STD-883 test method 1/	Symbol	Test conditions 2/ -55°C ≤ T <sub>C</sub> ≤ +125°C +4.5 V ≤ V <sub>CC</sub> ≤ +5.5 V unless otherwise specified	V <sub>CC</sub>	Group A subgroups	Limits 3/		Unit
					Min	Max	
Propagation delay time, mLE to mQn 3003	t <sub>PLH2</sub> 8/	C <sub>L</sub> = 50 pF minimum R <sub>L</sub> = 500Ω See figure 5	5.0 V	9	1.7	5.7	ns
			4.5 V and 5.5 V	10, 11	1.7	7.0	
	t <sub>PHL2</sub> 8/		5.0 V	9	2.3	5.6	ns
			4.5 V and 5.5 V	10, 11	2.3	6.3	
Propagation delay time, output enable, mOE to mQn 3003	t <sub>pZH</sub> 8/		5.0 V	9	1.1	5.0	ns
			4.5 V and 5.5 V	10, 11	1.1	6.4	
	t <sub>pZL</sub> 8/		5.0 V	9	1.5	4.9	ns
			4.5 V and 5.5 V	10, 11	1.5	5.8	
Propagation delay time, output disable, mOE to mQn 3003	t <sub>PHZ</sub> 8/	5.0 V	9	2.4	7.1	ns	
		4.5 V and 5.5 V	10, 11	2.4	8.5		
	t <sub>PLZ</sub> 8/	5.0 V	9	1.6	6.2	ns	
		4.5 V and 5.5 V	10, 11	1.6	8.0		
Setup time, data before LE↓	t <sub>s</sub> 9/	5.0 V	9	1.5		ns	
		4.5 V and 5.5 V	10, 11	1.5			
Hold time, data after LE↓	t <sub>h</sub> 9/	5.0 V	9	1.0		ns	
		4.5 V and 5.5 V	10, 11	1.0			
LE pulse width, high	t <sub>y</sub> 9/	5.0 V	9	3.3		ns	
		4.5 V and 5.5 V	10, 11	3.3			

See footnotes on next sheet.

<b>STANDARDIZED MILITARY DRAWING DEFENSE ELECTRONICS SUPPLY CENTER DAYTON, OHIO 45444</b>	<b>SIZE A</b>		<b>5962-93200</b>
		<b>REVISION LEVEL</b>	<b>SHEET 8</b>

DESC FORM 193A  
JUL 91

9004708 0006922 854



TABLE I. Electrical performance characteristics - Continued.

- 1/ For tests not listed in the referenced MIL-STD-883 (e.g.  $\Delta I_{CC}$ ), utilize the general test procedure of 883 under the conditions listed herein.
- 2/ Each input/output, as applicable, shall be tested at the specified temperature, for the specified limits, to the tests in table I herein. Output terminals not designated shall be high level logic, low level logic, or open, except for all  $I_{CC}$  and  $\Delta I_{CC}$  tests, where the output terminals shall be open. When performing these tests, the current meter shall be placed in the circuit such that all current flows through the meter. For input terminals not designated,  $V_{IN} = GND$  or  $V_{IN} \geq 3.0 V$ .
- 3/ For negative and positive voltage and current values, the sign designates the potential difference in reference to GND and the direction of current flow, respectively, and the absolute value of the magnitude, not the sign, is relative to the minimum and maximum limits, as applicable, listed herein. All devices shall meet or exceed the limits specified in table I at  $4.5 V \leq V_{CC} \leq 5.5 V$ .
- 4/ Not more than one output should be tested at one time, and the duration of the test condition should not exceed one second.
- 5/ This is the increase in supply current for each input that is at one of the specified TTL voltage levels rather than 0 V or  $V_{CC}$ . This test may be performed either one input at a time (preferred method) or with all input pins simultaneously at  $V_{IN} = V_{CC} - 2.1 V$  (alternate method). Classes Q and V shall use the preferred method. When the test is performed using the alternate test method, the maximum limit is equal to the number of inputs at a high TTL input level times 1.5 mA, and the preferred method and limits are guaranteed.
- 6/ This test is for qualification only. Ground and  $V_{CC}$  bounce tests are performed on a non-switching (quiescent) output and are used to measure the magnitude of induced noise caused by other simultaneously switching outputs. The test is performed on a low noise bench test fixture. For the device under test, all outputs shall be loaded with 500 $\Omega$  of load resistance and a minimum of 50 pF of load capacitance (see figure 4). Only chip capacitors and resistors shall be used. The output load components shall be located as close as possible to the device outputs. It is suggested, that whenever possible, this distance be kept to less than 0.25 inches. Decoupling capacitors shall be placed in parallel from  $V_{CC}$  to ground. The values of these decoupling capacitors shall be determined by the device manufacturer. The low and high level ground and  $V_{CC}$  bounce noise is measured at the quiet output using a 1 GHz minimum bandwidth oscilloscope with a 50 $\Omega$  input impedance.  
  
The device inputs shall be conditioned such that all outputs are at a high nominal  $V_{OH}$  level. The device inputs shall then be conditioned such that they switch simultaneously and the output under test remains at  $V_{OH}$  as all other outputs possible are switched from  $V_{OH}$  to  $V_{OL}$ .  $V_{OHV}$  and  $V_{OHP}$  are then measured from the nominal  $V_{OH}$  level to the largest negative and positive peaks, respectively (see figure 4). This is then repeated with the same outputs not under test switching from  $V_{OL}$  to  $V_{OH}$ .  
  
The device inputs shall be conditioned such that all outputs are at a low nominal  $V_{OL}$  level. The device inputs shall then be conditioned such that they switch simultaneously and the output under test remains at  $V_{OL}$  as all other outputs possible are switched from  $V_{OL}$  to  $V_{OH}$ .  $V_{OLP}$  and  $V_{OLV}$  are then measured from the nominal  $V_{OL}$  level to the largest positive and negative peaks, respectively (see figure 4). This is then repeated with the same outputs not under test switching from  $V_{OH}$  to  $V_{OL}$ .
- 7/ Tests shall be performed in sequence, attributes data only. Functional tests shall include the truth table and other logic patterns used for fault detection. The test vectors used to verify the truth table shall, at a minimum, test all functions of each input and output. All possible input to output logic patterns per function shall be guaranteed, if not tested, to the truth table in figure 2 herein. Functional tests shall be performed in sequence as approved by the qualifying activity on qualified devices. After incorporating allowable tolerances per MIL-STD-883,  $V_{IL} = 0.4 V$  and  $V_{IH} = 2.4 V$ . For outputs,  $L \leq 0.8 V$ ,  $H \geq 2.0 V$ .
- 8/ For propagation delay tests, all paths must be tested.
- 9/ This parameter shall be guaranteed, if not tested, to the limits specified in table I herein.

<b>STANDARDIZED MILITARY DRAWING DEFENSE ELECTRONICS SUPPLY CENTER DAYTON, OHIO 45444</b>	<b>SIZE A</b>		<b>5962-93200</b>
		<b>REVISION LEVEL</b>	<b>SHEET 9</b>

DESC FORM 193A  
JUL 91

■ 9004708 0006923 790 ■

Device type	01						
Case outline	X						
Terminal number	Terminal symbol	Terminal number	Terminal symbol	Terminal number	Terminal symbol	Terminal number	Terminal symbol
1	$\overline{10E}$	13	2Q1	25	2LE	37	108
2	1Q1	14	2Q2	26	2D8	38	1D7
3	1Q2	15	GND	27	2D7	39	GND
4	GND	16	2Q3	28	GND	40	1D6
5	1Q3	17	2Q4	29	2D6	41	1D5
6	1Q4	18	V <sub>CC</sub>	30	2D5	42	V <sub>CC</sub>
7	V <sub>CC</sub>	19	2Q5	31	V <sub>CC</sub>	43	1D4
8	1Q5	20	2Q6	32	2D4	44	1D3
9	1Q6	21	GND	33	2D3	45	GND
10	GND	22	2Q7	34	GND	46	1D2
11	1Q7	23	2Q8	35	2D2	47	1D1
12	1Q8	24	$\overline{20E}$	36	2D1	48	1LE

Terminal descriptions	
Terminal symbol	Description
mDn (m = 1 to 2, n = 1 to 8)	Data inputs
mQn (m = 1 to 2, n = 1 to 8)	Three-state outputs
$\overline{mOE}$ (m = 1 to 2)	Output enable control inputs
mLE (m = 1 to 2)	Latch enable control inputs

FIGURE 1. Terminal connections.

Device type 01			
Inputs			Outputs
$\overline{mOE}$	mLE	mDn	mQn
L	H	H	H
L	H	L	L
L	L	X	Q0
H	X	X	Z

H = High voltage level  
L = Low voltage level  
X = Irrelevant  
Z = Disabled  
Q0 = The level of Q before the indicated steady-state input conditions were established

FIGURE 2. Truth table.

<b>STANDARDIZED  MILITARY DRAWING  DEFENSE ELECTRONICS SUPPLY CENTER  DAYTON, OHIO 45444</b>	<b>SIZE  A</b>		<b>5962-93200</b>
		<b>REVISION LEVEL</b>	<b>SHEET  10</b>

DESC FORM 193A  
JUL 91

9004708 0006924 627

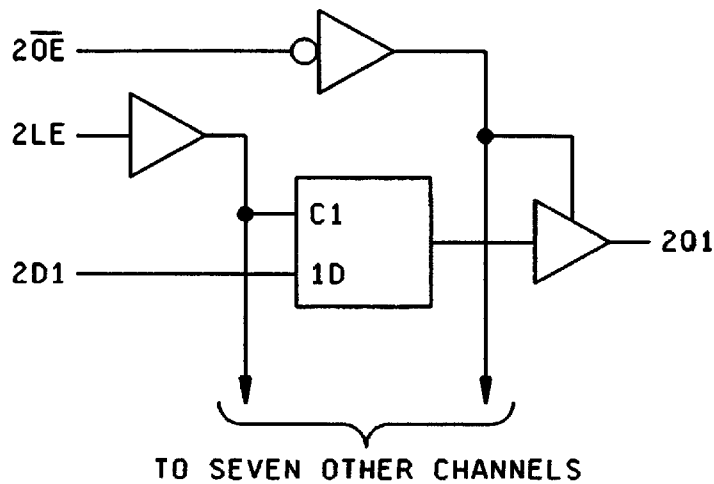
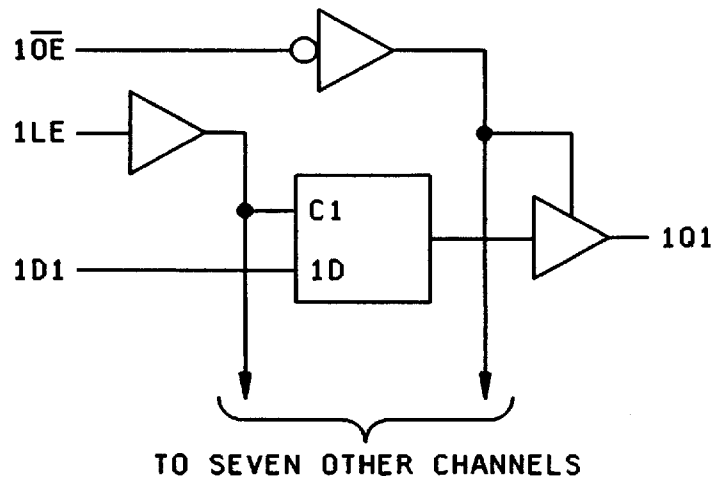
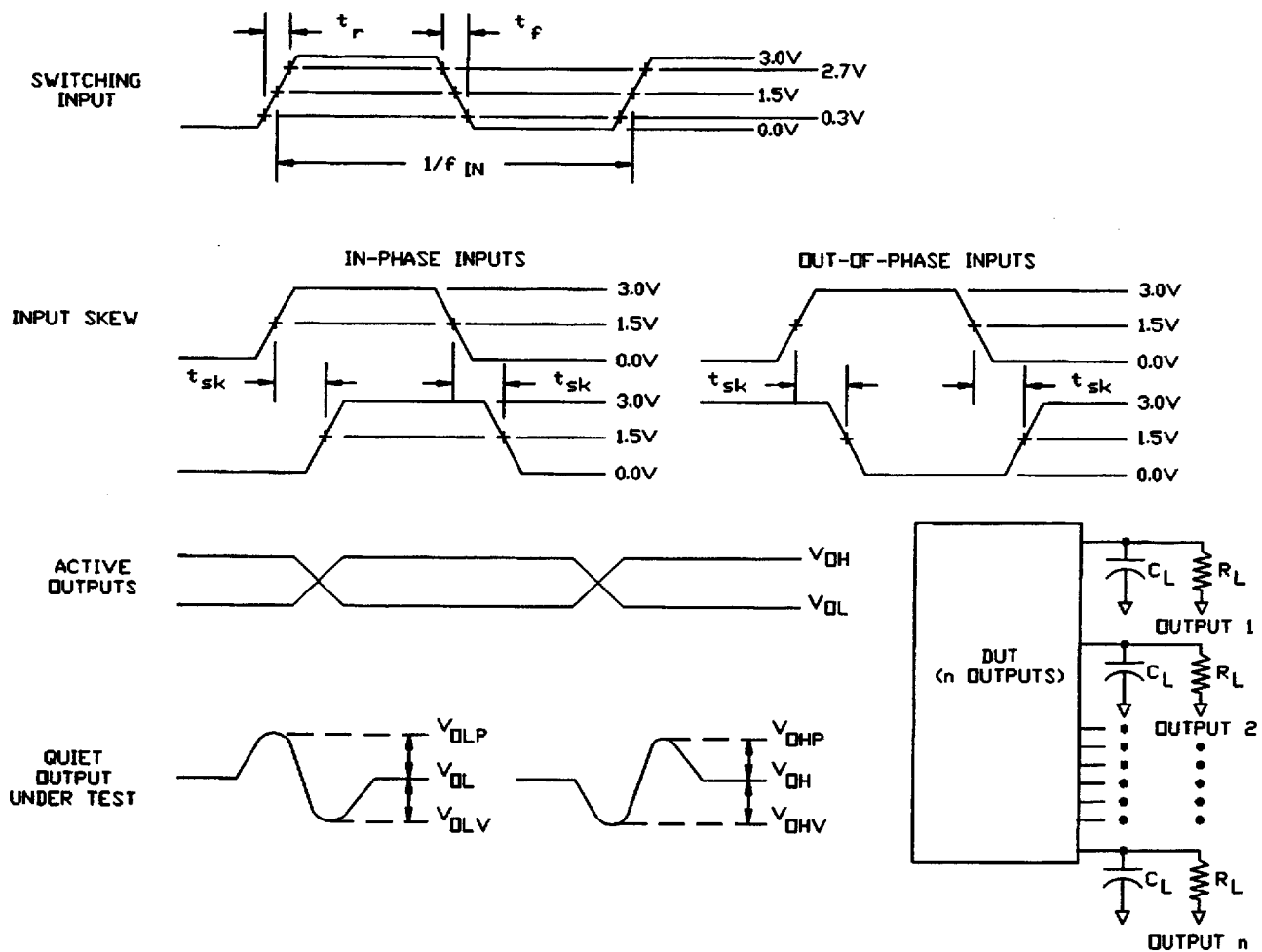

FIGURE 3. Logic diagram.

STANDARDIZED MILITARY DRAWING DEFENSE ELECTRONICS SUPPLY CENTER DAYTON, OHIO 45444	SIZE A		5962-93200
		REVISION LEVEL	SHEET 11

DESC FORM 193A  
 JUL 91

■ 9004708 0006925 563 ■



**NOTES:**

1.  $C_L$  includes a 47 pF chip capacitor (-0 percent, +20 percent) and at least 3 pF of equivalent capacitance from the test jig and probe.
2.  $R_L = 450\Omega \pm 1$  percent, chip resistor in series with a  $50\Omega$  termination. For monitored outputs, the  $50\Omega$  termination shall be the  $50\Omega$  characteristic impedance of the coaxial connector to the oscilloscope.
3. Input signal to the device under test:
  - a.  $V_{IN} = 0.0$  V to 3.0 V; duty cycle = 50 percent;  $f_{IN} \geq 1$  MHz.
  - b.  $t_r, t_f = 3$  ns  $\pm 1.0$  ns. For input signal generators incapable of maintaining these values of  $t_r$  and  $t_f$ , the 3.0 ns limit may be increased up to 10 ns, as needed, maintaining the  $\pm 1.0$  ns tolerance and guaranteeing the results at 3.0 ns  $\pm 1.0$  ns; skew between any two switching inputs signals ( $t_{sk}$ ):  $\leq 250$  ps.

FIGURE 4. Ground bounce load circuit and waveforms.

STANDARDIZED MILITARY DRAWING DEFENSE ELECTRONICS SUPPLY CENTER DAYTON, OHIO 45444	SIZE <b>A</b>		5962-93200
		REVISION LEVEL	SHEET 12

DESC FORM 193A  
JUL 91

■ 9004708 0006926 4TT ■

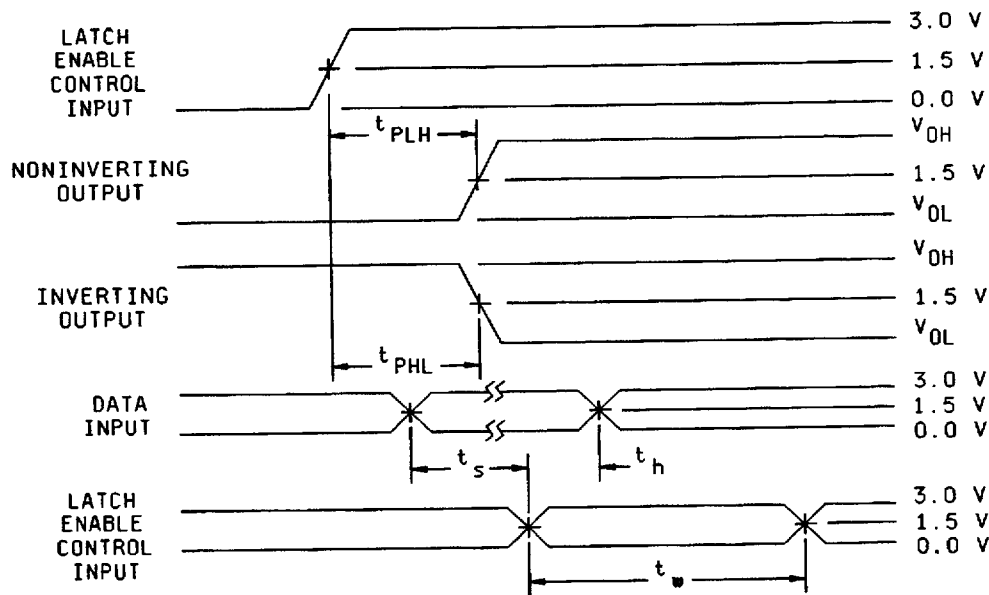
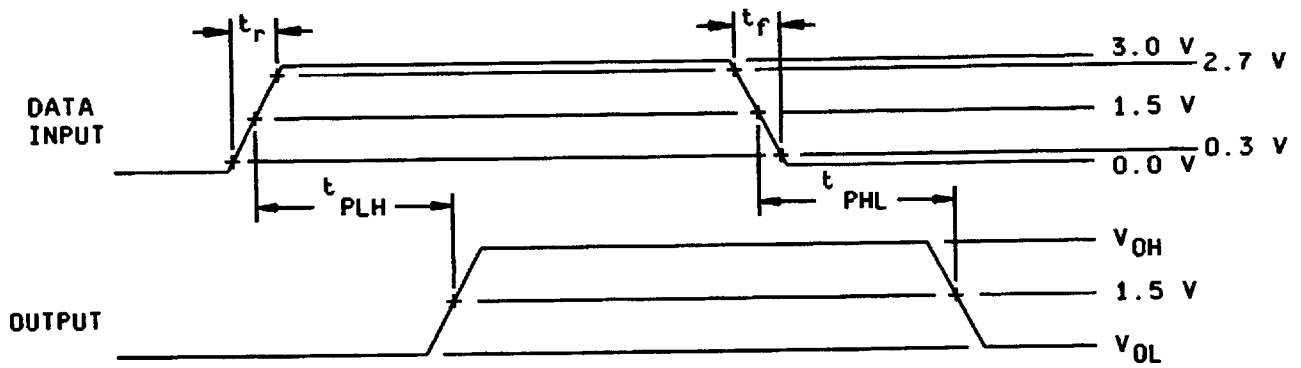

FIGURE 5. Switching waveforms and test circuit.

STANDARDIZED  
MILITARY DRAWING  
DEFENSE ELECTRONICS SUPPLY CENTER  
DAYTON, OHIO 45444

SIZE  
A

5962-93200

REVISION LEVEL

SHEET  
13

DESC FORM 193A  
JUL 91

9004708 0006927 336

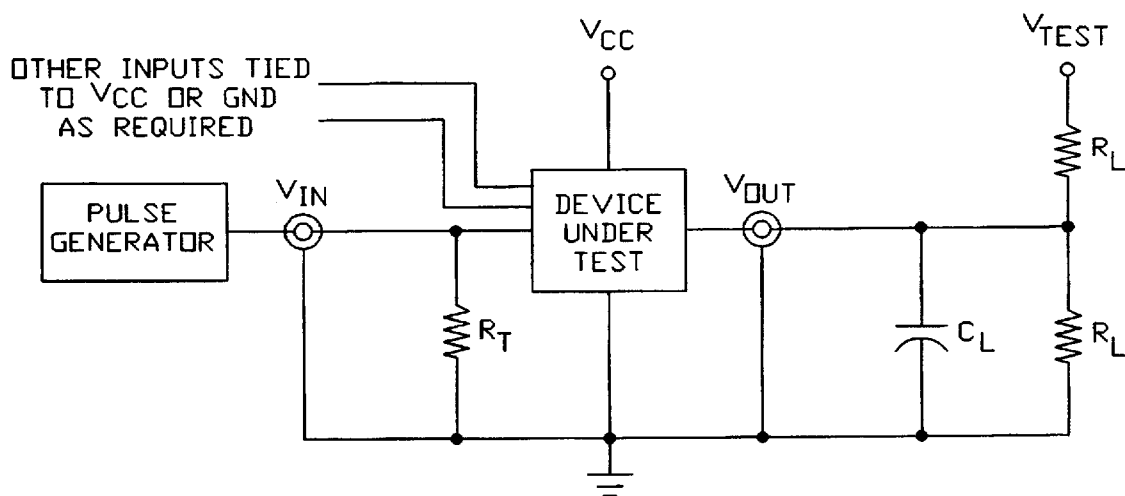
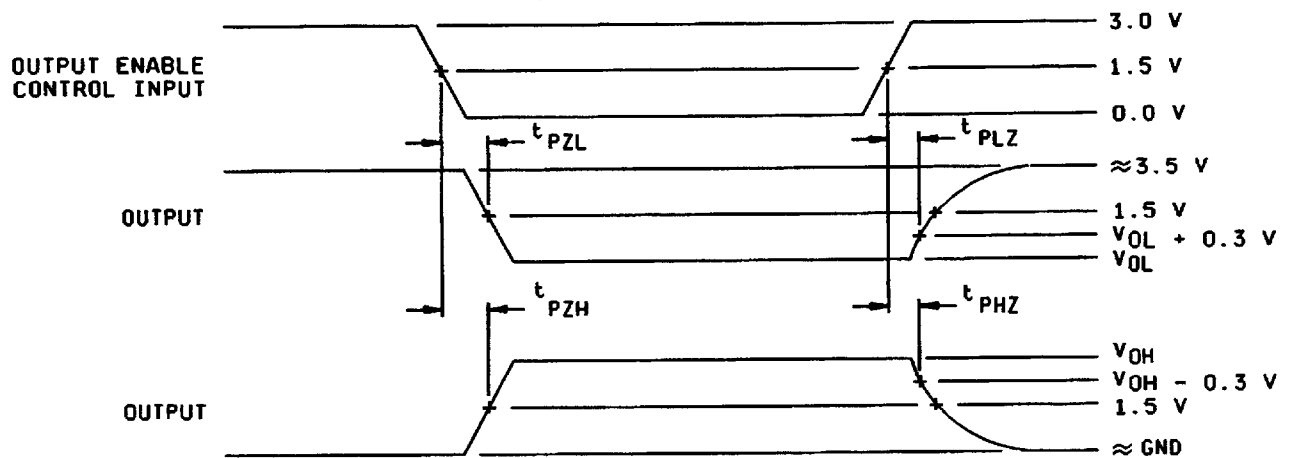

**NOTES:**

1. When measuring  $t_{PLZ}$  and  $t_{PZL}$ :  $V_{TEST} = 7.0\text{ V}$ .
2. When measuring  $t_{PHZ}$ ,  $t_{PZH}$ ,  $t_{PLH}$ , and  $t_{PHL}$ :  $V_{TEST} = \text{open}$ .
3. The  $t_{PZL}$  and  $t_{PLZ}$  reference waveform is for the output under test with internal conditions such that the output is at  $V_{OL}$  except when disabled by the output enable control. The  $t_{PZH}$  and  $t_{PHZ}$  reference waveform is for the output under test with internal conditions such that the output is at  $V_{OH}$  except when disabled by the output enable control.
4.  $C_L = 50\text{ pF}$  minimum or equivalent (includes test jig and probe capacitance).
5.  $R_L = 500\Omega$  or equivalent.
6.  $R_T = 50\Omega$  or equivalent.
7. Input signal from pulse generator:  $V_{IN} = 0.0\text{ V}$  to  $3.0\text{ V}$ ;  $PRR \leq 10\text{ MHz}$ ;  $t_r \leq 2.5\text{ ns}$ ;  $t_f \leq 2.5\text{ ns}$ ;  $t_r$  and  $t_f$  shall be measured from  $0.3\text{ V}$  to  $2.7\text{ V}$  and from  $2.7\text{ V}$  to  $0.3\text{ V}$ , respectively; duty cycle = 50 percent.
8. Timing parameters shall be tested at a minimum input frequency of 1 MHz.
9. The outputs are measured one at a time with one transition per measurement.

FIGURE 5. Switching waveforms and test circuit.

STANDARDIZED MILITARY DRAWING DEFENSE ELECTRONICS SUPPLY CENTER DAYTON, OHIO 45444	SIZE <b>A</b>		5962-93200
		REVISION LEVEL	SHEET 14

DESC FORM 193A  
JUL 91

9004708 0006928 272

TABLE II. Electrical test requirements.

Test requirements	Subgroups (in accordance with MIL-STD-883, TM 5005, table I)	Subgroups (in accordance with MIL-I-38535, table III)	
	Device class M	Device class Q	Device class V
Interim electrical parameters (see 4.2)	---	---	1
Final electrical parameters (see 4.2)	1, 2, 3, 7, 8, 9, 10, 11 1/	1, 2, 3, 7, 8, 9, 10, 11 1/	1, 2, 3, 7, 8, 9, 10, 11 2/
Group A test requirements (see 4.4)	1, 2, 3, 4, 7, 8, 9, 10, 11	1, 2, 3, 4, 7, 8, 9, 10, 11	1, 2, 3, 4, 7, 8, 9, 10, 11
Group C end-point electrical parameters (see 4.4)	1, 2, 3	1, 2, 3	1, 2, 3, 7, 8, 9, 10, 11
Group D end-point electrical parameters (see 4.4)	1, 2, 3	1, 2, 3	1, 2, 3
Group E end-point electrical parameters (see 4.4)	1, 7, 9	1, 7, 9	1, 7, 9

1/ PDA applies to subgroup 1.

2/ PDA applies to subgroups 1 and 7.

4.2.2 Additional criteria for device classes Q and V.

- a. The burn-in test duration, test condition and test temperature, or approved alternatives shall be as specified in the device manufacturer's QM plan in accordance with MIL-I-38535. The burn-in test circuit shall be maintained under document revision level control of the device manufacturer's Technology Review Board (TRB) in accordance with MIL-I-38535 and shall be made available to the preparing or acquiring activity upon request. The test circuit shall specify the inputs, outputs, biases, and power dissipation, as applicable, in accordance with the intent specified in test method 1015.
- b. Interim and final electrical test parameters shall be as specified in table II herein.
- c. Additional screening for device class V beyond the requirements of device class Q shall be as specified in appendix B of MIL-I-38535.

4.3 Qualification inspection for device classes Q and V. Qualification inspection for device classes Q and V shall be in accordance with MIL-I-38535. Inspections to be performed shall be those specified in MIL-I-38535 and herein for groups A, B, C, D, and E inspections (see 4.4.1 through 4.4.4).

4.3.1 Electrostatic discharge sensitivity qualification inspection. Electrostatic discharge sensitivity (ESDS) testing shall be performed in accordance with MIL-STD-883, method 3015. ESDS testing shall be measured only for initial qualification and after process or design changes which may affect ESDS classification.

4.4 Conformance inspection. Quality conformance inspection for device class M shall be in accordance with MIL-STD-883 (see 3.1 herein) and as specified herein. Inspections to be performed for device class M shall be those specified in method 5005 of MIL-STD-883 and herein for groups A, B, C, D, and E inspections (see 4.4.1 through 4.4.4). Technology conformance inspection for classes Q and V shall be in accordance with MIL-I-38535 including groups A, B, C, D, and E inspections and as specified herein except where option 2 of MIL-I-38535 permits alternate in-line control testing.

STANDARDIZED MILITARY DRAWING DEFENSE ELECTRONICS SUPPLY CENTER DAYTON, OHIO 45444	SIZE A		5962-93200
		REVISION LEVEL	SHEET 15

DESC FORM 193A  
JUL 91

9004708 0006929 109

4.4.1 Group A inspection.

a. Tests shall be as specified in table II herein.

b.  $C_{IN}$  and  $C_{OUT}$  shall be measured only for initial qualification and after process or design changes which may affect capacitance.  $C_{IN}$  and  $C_{OUT}$  shall be measured between the designated terminal and GND at a frequency of 1 MHz. This test may be performed at 10 MHz and guaranteed, if not tested, at 1 MHz. The DC bias for the pin under test ( $V_{BIAS}$ ) = 2.5 V or 3.0 V. For  $C_{IN}$  and  $C_{OUT}$ , test all applicable pins on five devices with zero failures.

For  $C_{IN}$  and  $C_{OUT}$ , a device manufacturer may qualify devices by functional groups. A specific functional group shall be composed of function types, that by design, will yield the same capacitance values when tested in accordance with table I herein. The device manufacturer shall set a functional group limit for the  $C_{IN}$  and  $C_{OUT}$  tests. The device manufacturer may then test one device function from a functional group to the limits and conditions specified herein. All other device functions in that particular functional group shall be guaranteed, if not tested, to the limits and conditions specified in table I herein. The device manufacturer shall submit to DESC-EC the device functions listed in each functional group and the test results for each device tested.

c. For device class M, subgroups 7 and 8 tests shall be sufficient to verify the truth table in figure 2 herein. The test vectors used to verify the truth table shall, at a minimum, test all functions of each input and output. All possible input to output logic patterns per function shall be guaranteed, if not tested, to the truth table in figure 2 herein. For device classes Q and V, subgroups 7 and 8 shall include verifying the functionality of the device; these tests shall have been fault graded in accordance with MIL-STD-883, test method 5012 (see 1.5 herein).

d. Ground and  $V_{CC}$  bounce tests are required for all device classes. These tests shall be performed only for initial qualification, after process or design changes which may affect the performance of the device, and any changes to the test fixture.  $V_{OLP}$ ,  $V_{OLV}$ ,  $V_{OHP}$ , and  $V_{OHV}$  shall be measured for the worst case outputs of the device. All other outputs shall be guaranteed, if not tested, to the limits established for the worst case outputs. The worst case outputs tested are to be determined by the manufacturer. Test 5 devices assembled in the worst case package type supplied to this document. All other package types shall be guaranteed, if not tested, to the limits established for the worst case package. The package type to be tested shall be determined by the manufacturer. The device manufacturer will submit to DESC-EC data that shall include all measured peak values for each device tested and detailed oscilloscope plots for each  $V_{OLP}$ ,  $V_{OLV}$ ,  $V_{OHP}$ , and  $V_{OHV}$  from one sample part per function. The plot shall contain the waveforms of both a switching output and the output under test.

Each device manufacturer shall test product on the fixtures they currently use. When a new fixture is used, the device manufacturer shall inform DESC-EC of this change and test the 5 devices on both the new and old test fixtures. The device manufacturer shall then submit to DESC-EC data from testing on both fixtures that shall include all measured peak values for each device tested and detailed oscilloscope plots for each  $V_{OLP}$ ,  $V_{OLV}$ ,  $V_{OHP}$ , and  $V_{OHV}$  from one sample part per function. The plot shall contain the waveforms of both a switching output and the output under test.

For  $V_{OLP}$ ,  $V_{OLV}$ ,  $V_{OHP}$ , and  $V_{OHV}$ , a device manufacturer may qualify devices by functional groups. A specific functional group shall be composed of function types, that by design, will yield the same test values when tested in accordance with table I herein. The device manufacturer shall set a functional group limit for the  $V_{OLP}$ ,  $V_{OLV}$ ,  $V_{OHP}$ , and  $V_{OHV}$  tests. The device manufacturer may then test one device function from a functional group to the limits and conditions specified herein. All other device functions in that particular functional group shall be guaranteed, if not tested, to the limits and conditions specified in table I herein. The device manufacturer shall submit to DESC-EC the device functions listed in each functional group and the test results, along with the oscilloscope plots, for each device tested.

4.4.2 Group C inspection. The group C inspection end-point electrical parameters shall be as specified in table II herein.

<b>STANDARDIZED MILITARY DRAWING DEFENSE ELECTRONICS SUPPLY CENTER DAYTON, OHIO 45444</b>	<b>SIZE A</b>		<b>5962-93200</b>
		<b>REVISION LEVEL</b>	<b>SHEET 16</b>

DESC FORM 193A  
JUL 91

■ 9004708 0006930 920 ■



4.4.2.1 Additional criteria for device class M. Steady-state life test conditions, method 1005 of MIL-STD-883:

- a. Test condition A, B, C or D. The test circuit shall be maintained by the manufacturer under document revision level control and shall be made available to the preparing or acquiring activity upon request. The test circuit shall specify the inputs, outputs, biases, and power dissipation, as applicable, in accordance with the intent specified in test method 1005.
- b.  $T_A = +125^\circ\text{C}$ , minimum.
- c. Test duration: 1,000 hours, except as permitted by method 1005 of MIL-STD-883.

4.4.2.2 Additional criteria for device classes Q and V. The steady-state life test duration, test condition and test temperature, or approved alternatives shall be as specified in the device manufacturer's QM plan in accordance with MIL-I-38535. The test circuit shall be maintained under document revision level control of the device manufacturer's TRB in accordance with MIL-I-38535 and shall be made available to the preparing or acquiring activity upon request. The test circuit shall specify the inputs, outputs, biases, and power dissipation, as applicable, in accordance with the intent specified in test method 1005.

4.4.3 Group D inspection. The group D inspection end-point electrical parameters shall be as specified in table II herein.

4.4.4 Group E inspection. Group E inspection is required only for parts intended to be marked as radiation hardness assured (see 3.5 herein). RHA levels for device classes Q and V shall be M, D, R, and H and RHA levels for device class M shall be M and D.

- a. End-point electrical parameters shall be as specified in table II herein.
- b. For device class M, the devices shall be subjected to radiation hardness assured tests as specified in MIL-I-38535, appendix A, for the RHA level being tested. For device classes Q and V, the devices or test vehicle shall be subjected to radiation hardness assured tests as specified in MIL-I-38535 for the RHA level being tested. All device classes must meet the postirradiation end-point electrical parameter limits as defined in table I at  $T_A = +25^\circ\text{C} \pm 5^\circ\text{C}$ , after exposure, to the subgroups specified in table II herein.
- c. When specified in the purchase order or contract, a copy of the RHA delta limits shall be supplied.

4.5 Methods of inspection. Methods of inspection shall be specified as follows:

4.5.1 Voltage and current. Unless otherwise specified, all voltages given are referenced to the microcircuit GND terminal. Currents given are conventional current and positive when flowing into the referenced terminal.

5. PACKAGING

5.1 Packaging requirements. The requirements for packaging shall be in accordance with MIL-STD-883 (see 3.1 herein) for device class M and MIL-I-38535 for device classes Q and V.

6. NOTES

6.1 Intended use. Microcircuits conforming to this drawing are intended for use for Government microcircuit applications (original equipment), design applications, and logistics purposes.

6.1.1 Replaceability. Microcircuits covered by this drawing will replace the same generic device covered by a contractor-prepared specification or drawing.

6.1.2 Substitutability. Device class Q devices will replace device class M devices.

6.2 Configuration control of SMD's. All proposed changes to existing SMD's will be coordinated with the users of record for the individual documents. This coordination will be accomplished in accordance with MIL-STD-973 using DD Form 1692, Engineering Change Proposal.

6.3 Record of users. Military and industrial users shall inform Defense Electronics Supply Center when a system application requires configuration control and which SMD's are applicable to that system. DESC will maintain a record of users and this list will be used for coordination and distribution of changes to the drawings. Users of drawings covering microelectronic devices (FSC 5962) should contact DESC-EC, telephone (513) 296-6047.

STANDARDIZED MILITARY DRAWING DEFENSE ELECTRONICS SUPPLY CENTER DAYTON, OHIO 45444	SIZE A		5962-93200
		REVISION LEVEL	SHEET 17

DESC FORM 193A  
 JUL 91

■ 9004708 0006931 867 ■

6.4 Comments. Comments on this drawing should be directed to DESC-EC, Dayton, Ohio 45444-5270, or telephone (513) 296-5377.

6.5 Abbreviations, symbols, and definitions. The abbreviations, symbols, and definitions used herein are defined in MIL-I-38535 and MIL-STD-1331, and as follows:

- GND - - - - - Ground zero voltage potential.
- I<sub>CC</sub> - - - - - Supply current.
- I<sub>IL</sub> - - - - - Input current low.
- I<sub>IH</sub> - - - - - Input current high.
- T<sub>C</sub> - - - - - Case temperature.
- T<sub>A</sub> - - - - - Ambient temperature.
- V<sub>CC</sub> - - - - - Positive supply voltage.
- V<sub>IC-</sub> - - - - - Negative input clamp voltage.
- C<sub>IN</sub> - - - - - Input terminal-to-GND capacitance.
- C<sub>OUT</sub> - - - - - Output terminal-to-GND capacitance.

6.6 One part - one part number system. The one part - one part number system described below has been developed to allow for transitions between identical generic devices covered by the three major microcircuit requirements documents (MIL-H-38534, MIL-I-38535, and 1.2.1 of MIL-STD-883) without the necessity for the generation of unique PIN's. The three military requirements documents represent different class levels, and previously when a device manufacturer upgraded military product from one class level to another, the benefits of the upgraded product were unavailable to the Original Equipment Manufacturer (OEM), that was contractually locked into the original unique PIN. By establishing a one part number system covering all three documents, the OEM can acquire to the highest class level available for a given generic device to meet system needs without modifying the original contract parts selection criteria.

<u>Military documentation format</u>	<u>Example PIN under new system</u>	<u>Manufacturing source listing</u>	<u>Document Listing</u>
New MIL-H-38534 Standardized Military Drawings	5962-XXXXXZZ(H or K)YY	QML-38534	MIL-BUL-103
New MIL-I-38535 Standardized Military Drawings	5962-XXXXXZZ(Q or V)YY	QML-38535	MIL-BUL-103
New 1.2.1 of MIL-STD-883 Standardized Military Drawings.	5962-XXXXXZZ(M)YY	MIL-BUL-103	MIL-BUL-103

6.7 Sources of supply.

6.7.1 Sources of supply for device classes Q and V. Sources of supply for device classes Q and V are listed in QML-38535. The vendors listed in QML-38535 have submitted a certificate of compliance (see 3.6 herein) to DESC-EC and have agreed to this drawing.

6.7.2 Approved sources of supply for device class M. Approved sources of supply for class M are listed in MIL-BUL-103. The vendors listed in MIL-BUL-103 have agreed to this drawing and a certificate of compliance (see 3.6 herein) has been submitted to and accepted by DESC-EC.

<b>STANDARDIZED MILITARY DRAWING DEFENSE ELECTRONICS SUPPLY CENTER DAYTON, OHIO 45444</b>	<b>SIZE A</b>		<b>5962-93200</b>
		<b>REVISION LEVEL</b>	<b>SHEET 18</b>

DESC FORM 193A  
JUL 91