



## 10N60

Power MOSFET

### 10A, 600V N-CHANNEL POWER MOSFET

#### DESCRIPTION

The **UTC 10N60** is a high voltage and high current power MOSFET, designed to have better characteristics, such as fast switching time, low gate charge, low on-state resistance and have a high rugged avalanche characteristics. This power MOSFET is usually used at high speed switching applications in power supplies, PWM motor controls, high efficient DC to DC converters and bridge circuits.

#### FEATURES

- \*  $R_{DS(ON)} = 0.8\Omega @ V_{GS} = 10V$
- \* Low gate charge ( typical 44nC)
- \* Low  $C_{RSS}$  ( typical 18 pF)
- \* Fast switching
- \* 100% avalanche tested
- \* Improved dv/dt capability

#### SYMBOL

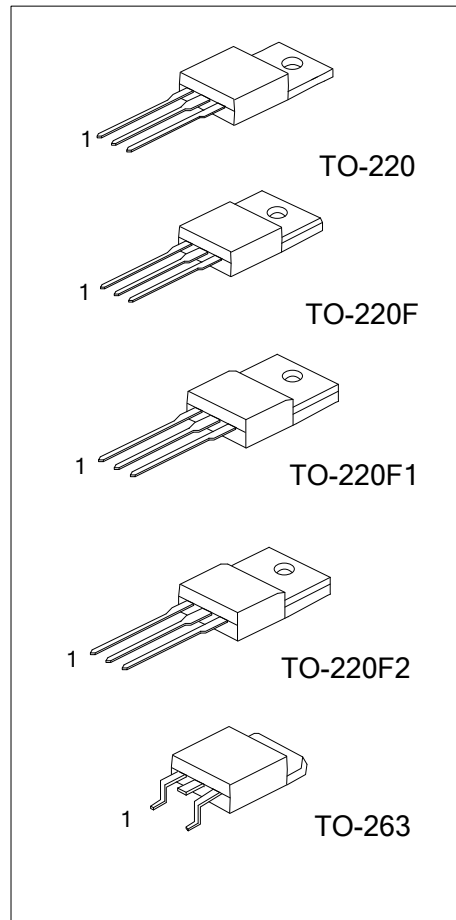
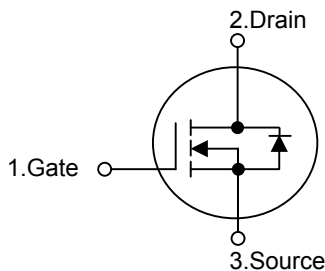

#### ORDERING INFORMATION

Ordering Number		Package	Pin Assignment			Packing
Lead Free	Halogen Free		1	2	3	
10N60L-TA3-T	10N60G-TA3-T	TO-220	G	D	S	Tube
10N60L-TF1-T	10N60G-TF1-T	TO-220F1	G	D	S	Tube
10N60L-TF2-T	10N60G-TF2-T	TO-220F2	G	D	S	Tube
10N60L-TF3-T	10N60G-TF3-T	TO-220F	G	D	S	Tube
10N60L-TQ2-R	10N60G-TQ2-R	TO-263	G	D	S	Tape Reel
10N60L-TQ2-T	10N60G-TQ2-T	TO-263	G	D	S	Tube

Note: Pin Assignment: G: Gate D: Drain S: Source

<p>10N60L-TA3-T</p> <p>(1)Packing Type</p> <p>(2)Package Type</p> <p>(3)Lead Free</p>	<p>(1) R: Tape Reel, T: Tube</p> <p>(2) TA3: TO-220, TF1: TO220-F1, TF2: TO-220F2, TF3: TO-220F, TQ2: TO-263</p> <p>(3) G: Halogen Free, L: Lead Free</p>
---	---

■ ABSOLUTE MAXIMUM RATINGS ( $T_C = 25^\circ\text{C}$  unless otherwise specified)

PARAMETER		SYMBOL	RATINGS	UNIT
Drain-Source Voltage		$V_{DSS}$	600	V
Gate-Source Voltage		$V_{GSS}$	$\pm 30$	V
Avalanche Current (Note 2)		$I_{AR}$	10	A
Drain Current	Continuous	$I_D$	10	A
	Pulsed (Note 2)	$I_{DM}$	38	A
Avalanche Energy	Single Pulsed (Note 3)	$E_{AS}$	700	mJ
	Repetitive (Note 2)	$E_{AR}$	15.6	mJ
Peak Diode Recovery $dv/dt$ (Note 4)		$dv/dt$	4.5	V/ns
Power Dissipation	TO-220/ TO-263	$P_D$	156	W
	TO-220F/TO-220F1		50	
	TO-220F2		52	
Junction Temperature		$T_J$	+150	$^\circ\text{C}$
Operating Temperature		$T_{OPR}$	-55 ~ +150	$^\circ\text{C}$
Storage Temperature		$T_{STG}$	-55 ~ +150	$^\circ\text{C}$

Notes: 1. Absolute maximum ratings are those values beyond which the device could be permanently damaged.

Absolute maximum ratings are stress ratings only and functional device operation is not implied.

2. Repetitive Rating: Pulse width limited by maximum junction temperature

3.  $L = 14.2\text{mH}$ ,  $I_{AS} = 10\text{A}$ ,  $V_{DD} = 50\text{V}$ ,  $R_G = 25\ \Omega$  Starting  $T_J = 25^\circ\text{C}$

4.  $I_{SD} \leq 9.5\text{A}$ ,  $di/dt \leq 200\text{A}/\mu\text{s}$ ,  $V_{DD} \leq BV_{DSS}$ , Starting  $T_J = 25^\circ\text{C}$

■ THERMAL DATA

PARAMETER		SYMBOL	RATING	UNIT
Junction to Ambient		$\theta_{JA}$	62.5	$^\circ\text{C}/\text{W}$
Junction to Case	TO-220	$\theta_{JC}$	0.8	$^\circ\text{C}/\text{W}$
	TO-220F/TO-220F1		2.5	
	TO-220F2		2.4	
	TO-263		0.7	

■ ELECTRICAL CHARACTERISTICS ( $T_C=25^\circ\text{C}$ , unless otherwise specified)

PARAMETER	SYMBOL	TEST CONDITIONS	MIN	TYP	MAX	UNIT
<b>OFF CHARACTERISTICS</b>						
Drain-Source Breakdown Voltage	$BV_{DSS}$	$V_{GS} = 0\text{V}$ , $I_D = 250\mu\text{A}$	600			V
Drain-Source Leakage Current	$I_{DSS}$	$V_{DS} = 600\text{V}$ , $V_{GS} = 0\text{V}$			1	$\mu\text{A}$
Gate-Source Leakage Current	Forward	$I_{GSS}$	$V_{GS} = 30\text{V}$ , $V_{DS} = 0\text{V}$		100	nA
Breakdown Voltage Temperature Coefficient	$\Delta BV_{DSS}/\Delta T_J$	$I_D=250\mu\text{A}$ , Referenced to $25^\circ\text{C}$		0.7		$\text{V}/^\circ\text{C}$
<b>ON CHARACTERISTICS</b>						
Gate Threshold Voltage	$V_{GS(TH)}$	$V_{DS} = V_{GS}$ , $I_D = 250\mu\text{A}$	2.0		4.0	V
Static Drain-Source On-State Resistance	$R_{DS(ON)}$	$V_{GS} = 10\text{V}$ , $I_D = 4.75\text{A}$		0.72	0.8	$\Omega$
<b>DYNAMIC CHARACTERISTICS</b>						
Input Capacitance	$C_{ISS}$	$V_{DS}=25\text{V}$ , $V_{GS}=0\text{V}$ , $f=1.0\text{MHz}$		1570	2040	pF
Output Capacitance	$C_{OSS}$			166	215	pF
Reverse Transfer Capacitance	$C_{RSS}$			18	24	pF
Gate Resistance	$R_G$	$V_{DS}=0\text{V}$ , $V_{GS}=0\text{V}$ , $f=1\text{MHz}$	0.25		1.4	$\Omega$

■ ELECTRICAL CHARACTERISTICS(Cont.)

PARAMETER	SYMBOL	TEST CONDITIONS	MIN	TYP	MAX	UNIT
<b>SWITCHING CHARACTERISTICS</b>						
Turn-On Delay Time	$t_{D(ON)}$	$V_{DD}=300V, I_D=10A,$ $R_G=25\Omega$ (Note 1, 2)		23	55	ns
Turn-On Rise Time	$t_R$			69	150	ns
Turn-Off Delay Time	$t_{D(OFF)}$			144	300	ns
Turn-Off Fall Time	$t_F$			77	165	ns
Total Gate Charge	$Q_G$	$V_{DS}=480V, I_D=10A,$ $V_{GS}=10V$ (Note 1, 2)		44	57	nC
Gate-Source Charge	$Q_{GS}$			6.7		nC
Gate-Drain Charge	$Q_{GD}$			18.5		nC
<b>DRAIN-SOURCE DIODE CHARACTERISTICS AND MAXIMUM RATINGS</b>						
Drain-Source Diode Forward Voltage	$V_{SD}$	$V_{GS} = 0V, I_S = 10A$			1.4	V
Maximum Continuous Drain-Source Diode Forward Current	$I_S$				10	A
Maximum Pulsed Drain-Source Diode Forward Current	$I_{SM}$				38	A
Reverse Recovery Time	$t_{rr}$	$V_{GS} = 0V, I_S = 10A,$ $di_F / dt = 100 A/\mu s$ (Note 1)		420		ns
Reverse Recovery Charge	$Q_{RR}$			4.2		$\mu C$

Notes: 1. Pulse Test : Pulse width  $\leq 300\mu s$ , Duty cycle  $\leq 2\%$

2. Essentially independent of operating temperature

■ TEST CIRCUITS AND WAVEFORMS

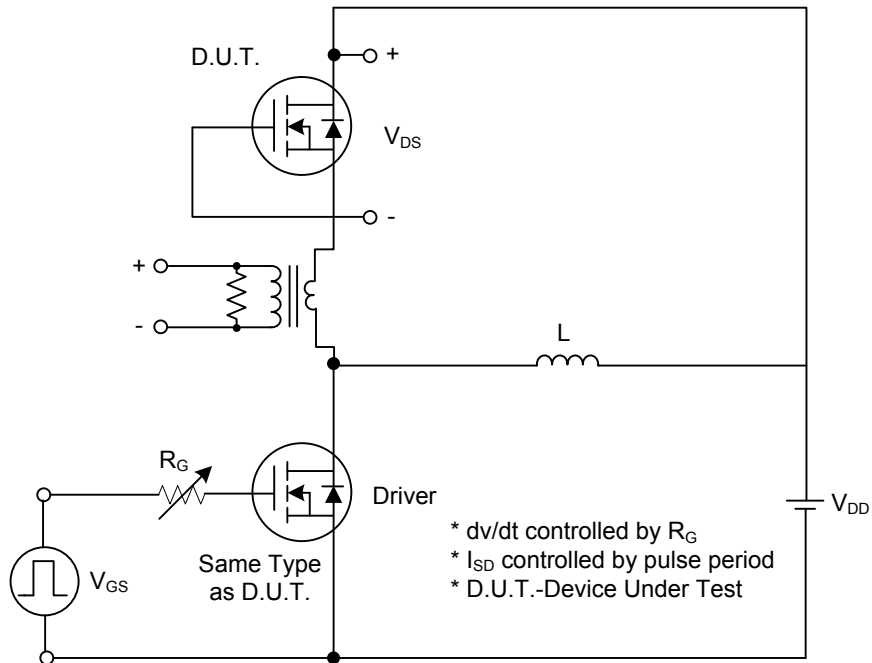

Peak Diode Recovery  $dv/dt$  Test Circuit

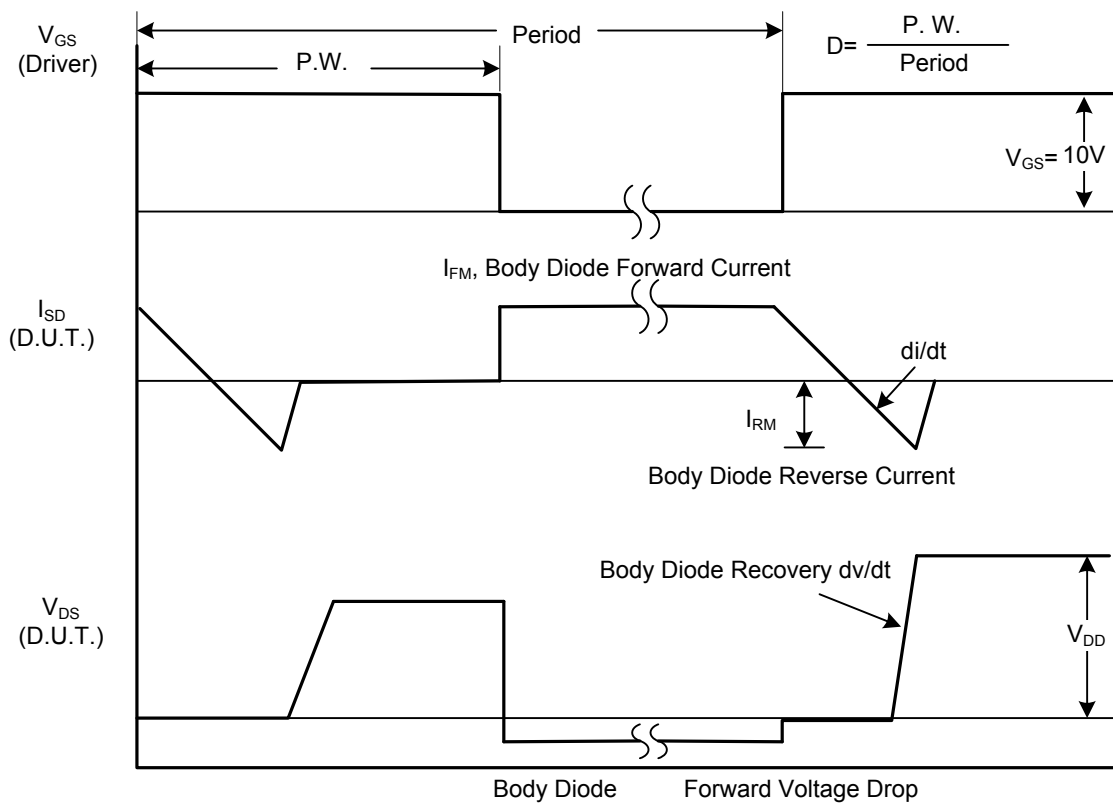

Peak Diode Recovery  $dv/dt$  Waveforms

## TEST CIRCUITS AND WAVEFORMS (Cont.)

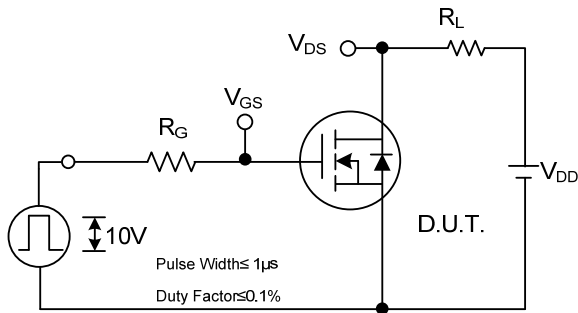

**Switching Test Circuit**

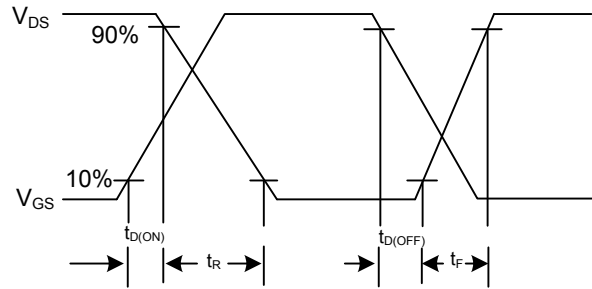

**Switching Waveforms**

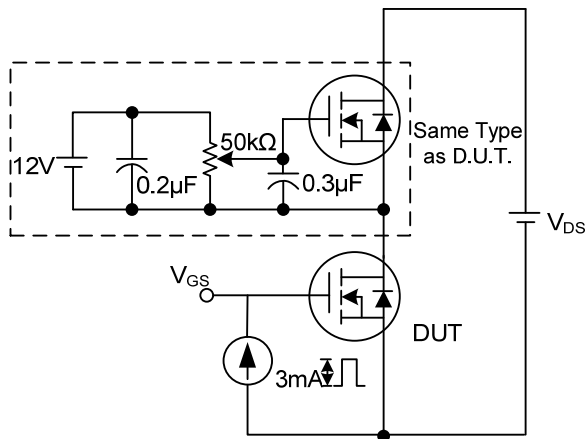

**Gate Charge Test Circuit**

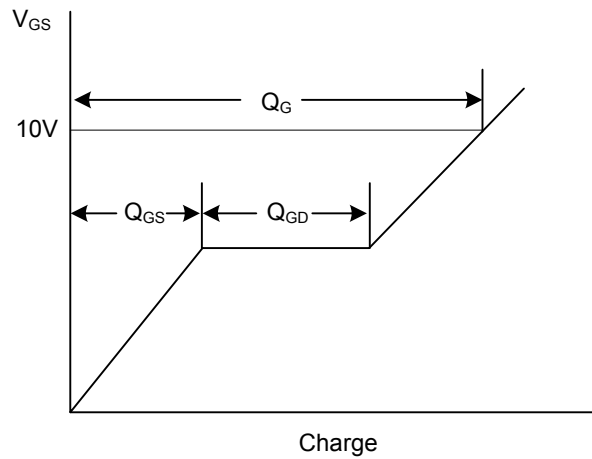

**Gate Charge Waveform**

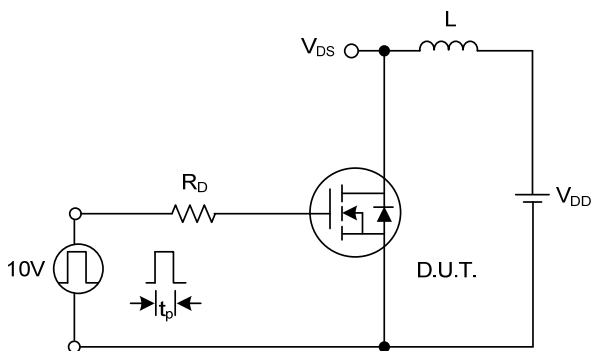

**Unclamped Inductive Switching Test Circuit**

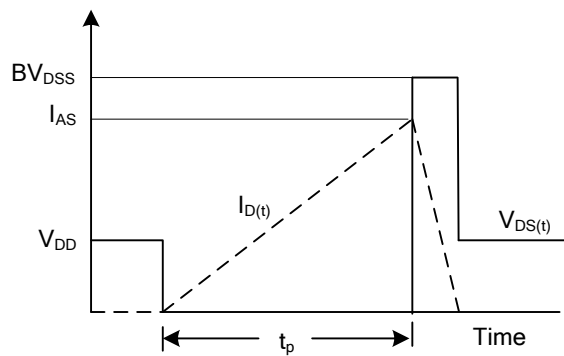

**Unclamped Inductive Switching Waveforms**

## TYPICAL CHARACTERISTICS

### On-Region Characteristics

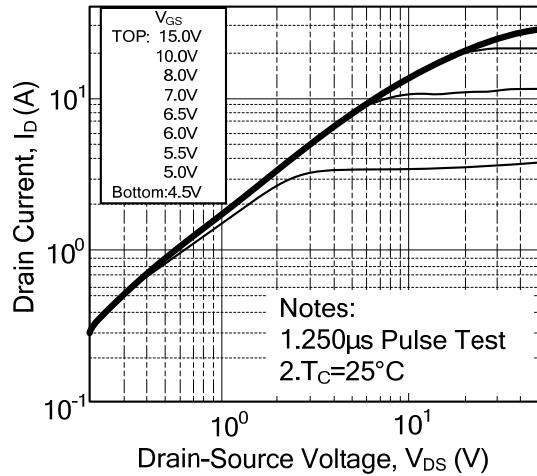

### Transfer Characteristics

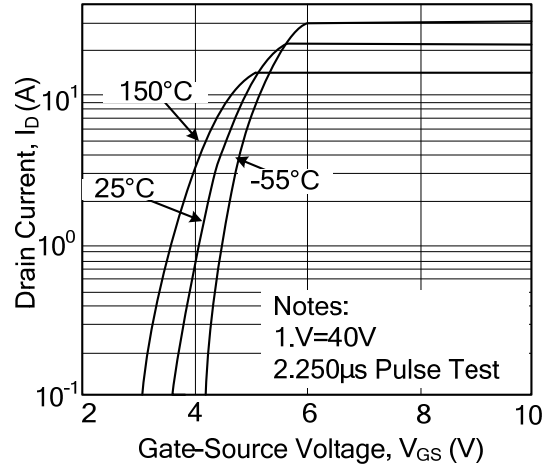

### On-Resistance Variation vs. Drain Current and Gate Voltage

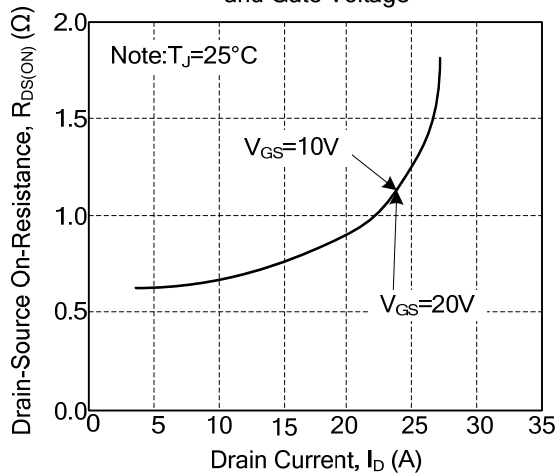

### Body Diode Forward Voltage Variation with Source Current and Temperature

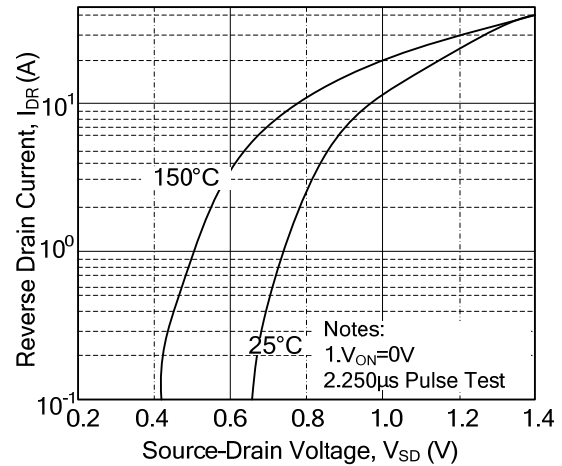

### Capacitance Characteristics

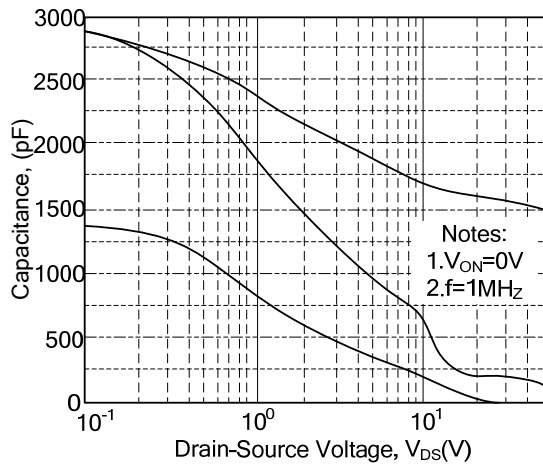

### Gate Charge Characteristics

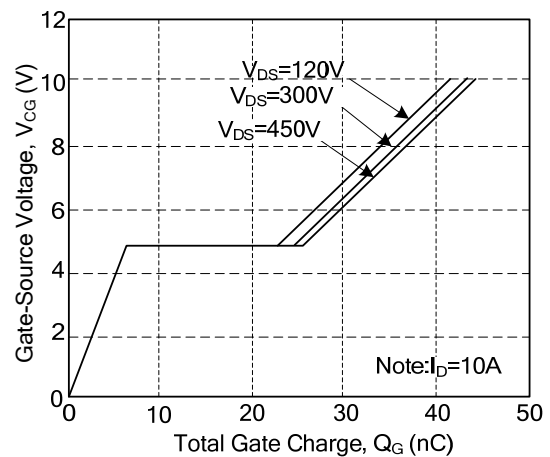

## ■ TYPICAL CHARACTERISTICS(Cont.)

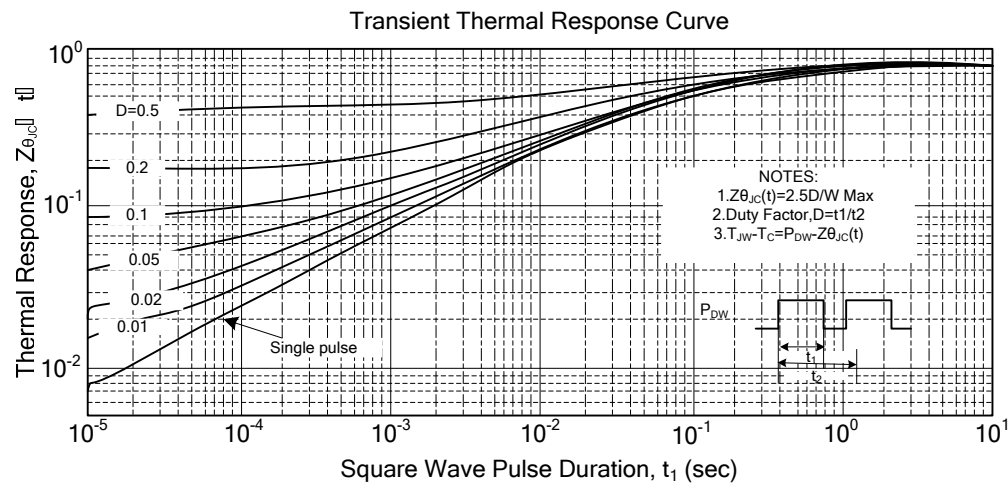
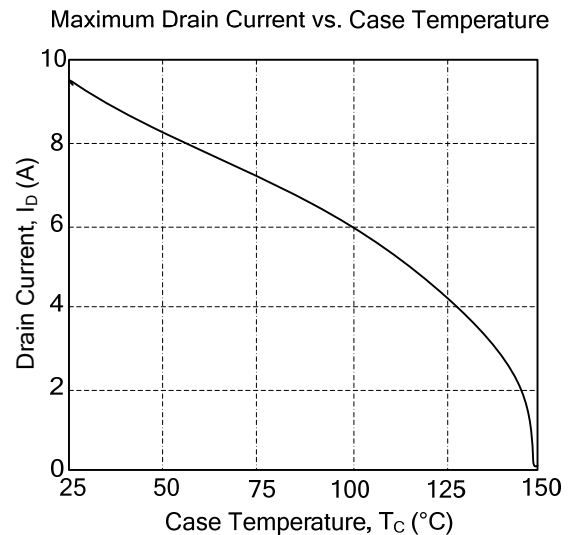
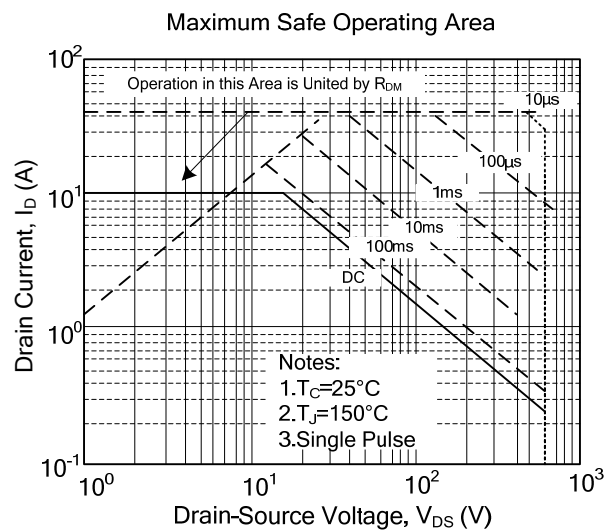
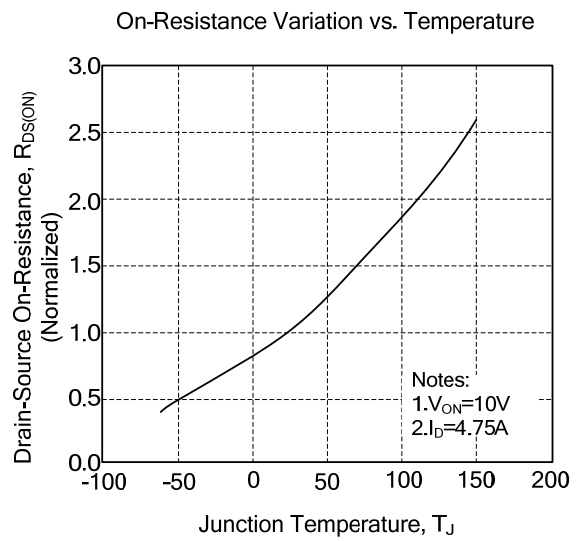
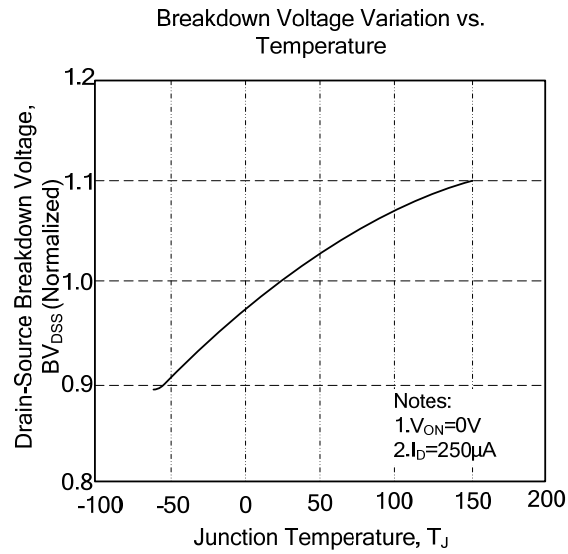

UTC assumes no responsibility for equipment failures that result from using products at values that exceed, even momentarily, rated values (such as maximum ratings, operating condition ranges, or other parameters) listed in products specifications of any and all UTC products described or contained herein. UTC products are not designed for use in life support appliances, devices or systems where malfunction of these products can be reasonably expected to result in personal injury. Reproduction in whole or in part is prohibited without the prior written consent of the copyright owner. The information presented in this document does not form part of any quotation or contract, is believed to be accurate and reliable and may be changed without notice.