

DATA SHEET

TJA1054 Fault-tolerant CAN transceiver

Product specification
Supersedes data of 2001 Nov 20

2004 Mar 23

Fault-tolerant CAN transceiver

TJA1054

FEATURES

Optimized for in-car low-speed communication

- Baud rate up to 125 kBaud
- Up to 32 nodes can be connected
- Supports unshielded bus wires
- Very low ElectroMagnetic Emission (EME) due to built-in slope control function and a very good matching of the CANL and CANH bus outputs
- Good ElectroMagnetic Immunity (EMI) in normal operating mode and in low power modes
- Fully integrated receiver filters
- Transmit Data (TxD) dominant time-out function.

Bus failure management

- Supports single-wire transmission modes with ground offset voltages up to 1.5 V
- Automatic switching to single-wire mode in the event of bus failures, even when the CANH bus wire is short-circuited to V_{CC}
- Automatic reset to differential mode if bus failure is removed
- Full wake-up capability during failure modes.

Protections

- Bus pins short-circuit safe to battery and to ground
- Thermally protected
- Bus lines protected against transients in an automotive environment
- An unpowered node does not disturb the bus lines.

Support for low power modes

- Low current sleep and standby mode with wake-up via the bus lines
- Power-on reset flag on the output.

ORDERING INFORMATION

TYPE NUMBER	PACKAGE		
	NAME	DESCRIPTION	VERSION
TJA1054T	SO14	plastic small outline package; 14 leads; body width 3.9 mm	SOT108-1
TJA1054U	–	bare die; 1990 × 2700 × 375 μm	–

GENERAL DESCRIPTION

The TJA1054 is the interface between the protocol controller and the physical bus wires in a Controller Area Network (CAN). It is primarily intended for low-speed applications up to 125 kBaud in passenger cars. The device provides differential receive and transmit capability but will switch to single-wire transmitter and/or receiver in error conditions.

The TJA1054T is pin and downwards compatible with the PCA82C252T and the TJA1053T. This means that these two devices can be replaced by the TJA1054T with retention of all functions.

The most important improvements of the TJA1054 with respect to the PCA82C252 and the TJA1053 are:

- Very low EME due to a very good matching of the CANL and CANH output signals
- Good EMI, especially in low power modes
- Full wake-up capability during bus failures
- Extended bus failure management including short-circuit of the CANH bus line to V_{CC}
- Support for easy system fault diagnosis
- Two-edge sensitive wake-up input signal via pin \overline{WAKE} .

Fault-tolerant CAN transceiver

TJA1054

QUICK REFERENCE DATA

SYMBOL	PARAMETER	CONDITIONS	MIN.	TYP.	MAX.	UNIT
V_{CC}	supply voltage on pin V_{CC}		4.75	–	5.25	V
V_{BAT}	battery voltage on pin BAT	no time limit	–0.3	–	+40	V
		operating mode; note 1	5.0	–	27	V
		load dump	–	–	40	V
I_{BAT}	battery current on pin BAT	sleep mode; $V_{CC} = 0$ V; $V_{BAT} = 12$ V	–	30	50	μ A
V_{CANH}	CANH bus line voltage	$V_{CC} = 0$ to 5.0 V; $V_{BAT} \geq 0$ V; no time limit	–40	–	+40	V
V_{CANL}	CANL bus line voltage	$V_{CC} = 0$ to 5.0 V; $V_{BAT} \geq 0$ V; no time limit	–40	–	+40	V
ΔV_{CANH}	CANH bus line transmitter voltage drop	$I_{CANH} = -40$ mA	–	–	1.4	V
ΔV_{CANL}	CANL bus line transmitter voltage drop	$I_{CANL} = 40$ mA	–	–	1.4	V
$t_{PD(L)}$	propagation delay TXD (LOW) to RXD (LOW)		–	1	–	μ s
t_r	bus line output rise time	between 10% and 90%; $C1 = 10$ nF; see Fig.5	–	0.6	–	μ s
t_f	bus line output fall time	between 10% and 90%; $C1 = 1$ nF; see Fig.5	–	0.3	–	μ s
T_{vj}	virtual junction temperature		–40	–	+150	$^{\circ}$ C

Note

1. A local or remote wake-up event will be signalled at the transceiver pins RXD and NERR if $V_{BAT} = 5.3$ V to 27 V (see Table 2).

Fault-tolerant CAN transceiver

TJA1054

BLOCK DIAGRAM

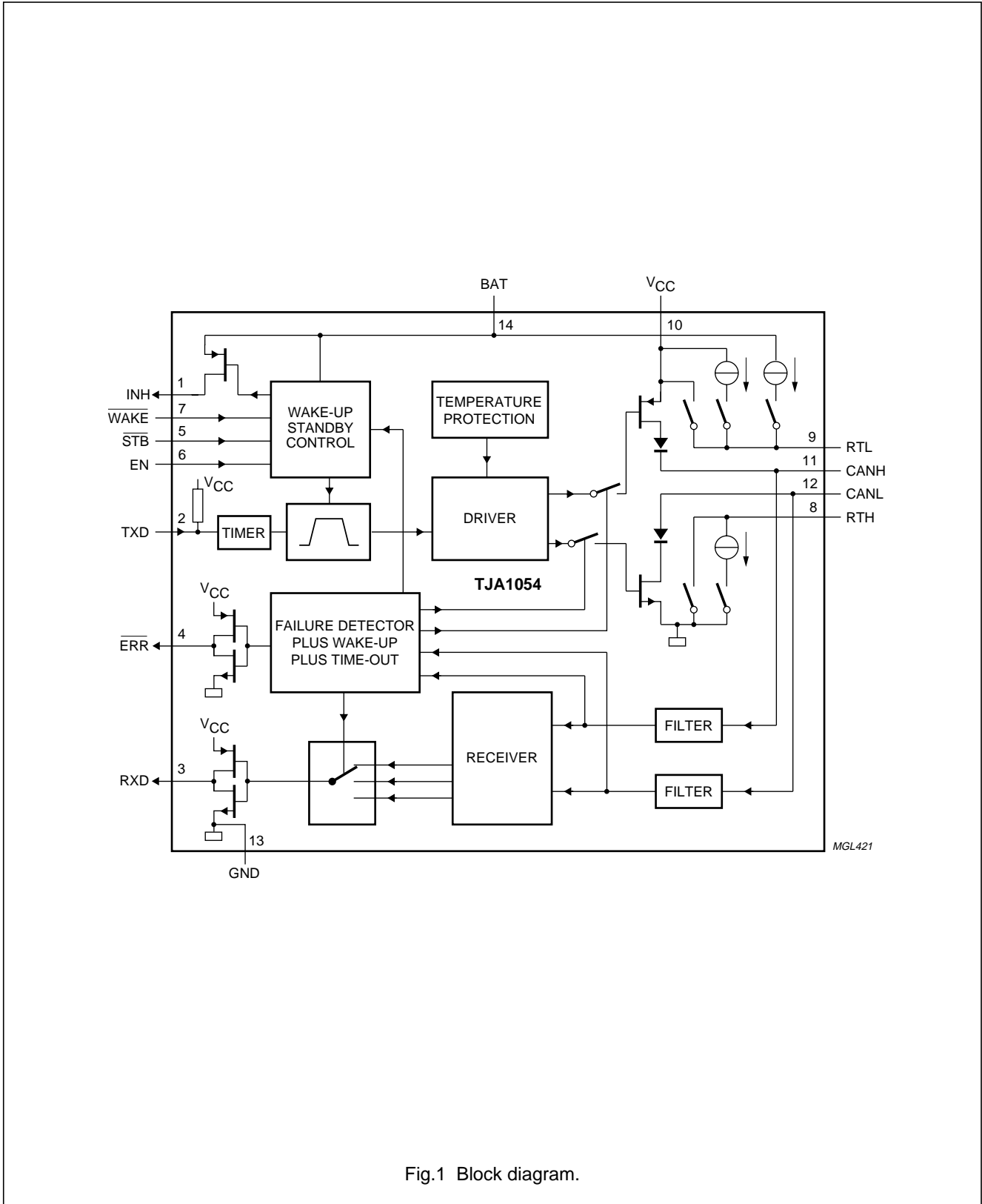

Fig.1 Block diagram.

Fault-tolerant CAN transceiver

TJA1054

PINNING

SYMBOL	PIN	DESCRIPTION
INH	1	inhibit output for switching an external voltage regulator if a wake-up signal occurs
TXD	2	transmit data input for activating the driver to the bus lines
RXD	3	receive data output for reading out the data from the bus lines
ERR	4	error, wake-up and power-on indication output; active LOW in normal operating mode when the bus has a failure, and in low power modes (wake-up signal or in power-on standby)
STB	5	standby digital control signal input (active LOW); together with the input signal on pin EN this input determines the state of the transceiver (in normal and low power modes); see Table 2 and Fig.3
EN	6	enable digital control signal input; together with the input signal on pin \overline{STB} this input determines the state of the transceiver (in normal and low power modes); see Table 2 and Fig.3
WAKE	7	local wake-up signal input (active LOW); both falling and rising edges are detected
RTH	8	termination resistor connection; in case of a CANH bus wire error the line is terminated with a predefined impedance
RTL	9	termination resistor connection; in case of a CANL bus wire the line is terminated with a predefined impedance
V _{CC}	10	supply voltage
CANH	11	HIGH-level CAN bus line
CANL	12	LOW-level CAN bus line
GND	13	ground
BAT	14	battery supply voltage

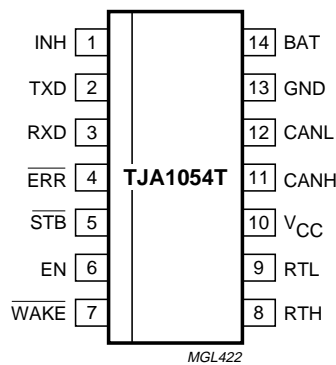

Fig.2 Pin configuration.

Fault-tolerant CAN transceiver

TJA1054

FUNCTIONAL DESCRIPTION

The TJA1054 is the interface between the CAN protocol controller and the physical wires of the CAN bus (see Fig.7). It is primarily intended for low-speed applications, up to 125 kBaud, in passenger cars. The device provides differential transmit capability to the CAN bus and differential receive capability to the CAN controller.

To reduce EME, the rise and fall slopes are limited. This allows the use of an unshielded twisted pair or a parallel pair of wires for the bus lines. Moreover, the device supports transmission capability on either bus line if one of the wires is corrupted. The failure detection logic automatically selects a suitable transmission mode.

In normal operating mode (no wiring failures) the differential receiver is output on pin RXD (see Fig.1). The differential receiver inputs are connected to pins CANH and CANL through integrated filters. The filtered input signals are also used for the single-wire receivers. The receivers connected to pins CANH and CANL have threshold voltages that ensure a maximum noise margin in single-wire mode.

A timer function (TxD dominant time-out function) has been integrated to prevent the bus lines from being driven into a permanent dominant state (thus blocking the entire network communication) due to a situation in which pin TXD is permanently forced to a LOW level, caused by a hardware and/or software application failure.

If the duration of the LOW level on pin TXD exceeds a certain time, the transmitter will be disabled. The timer will be reset by a HIGH level on pin TXD.

Failure detector

The failure detector is fully active in the normal operating mode. After the detection of a single bus failure the detector switches to the appropriate mode (see Table 1). The differential receiver threshold voltage is set at -3.2 V typical ($V_{CC} = 5$ V). This ensures correct reception with a noise margin as high as possible in the normal operating mode and in the event of failures 1, 2, 5 and 6a. These failures, or recovery from them, do not destroy ongoing transmissions. The output drivers remain active, the termination does not change and the receiver remains in differential mode (see Table 1).

Failures 3, 3a and 6 are detected by comparators connected to the CANH and CANL bus lines.

Failures 3 and 3a are detected in a two-step approach. If the CANH bus line exceeds a certain voltage level, the differential comparator signals a continuous dominant condition. Because of inter operability reasons with the predecessor products PCA82C252 and TJA1053, after a first time-out the transceiver switches to single-wire operation through CANH. If the CANH bus line is still exceeding the CANH detection voltage for a second time-out, the TJA1054 switches to CANL operation; the CANH driver is switched off and the RTH bias changes to the pull-down current source. The time-outs (delays) are needed to avoid false triggering by external RF fields.

Table 1 Bus failures

FAILURE	DESCRIPTION	TERMINATION CANH (RTH)	TERMINATION CANL (RTL)	CANH DRIVER	CANL DRIVER	RECEIVER MODE
1	CANH wire interrupted	on	on	on	on	differential
2	CANL wire interrupted	on	on	on	on	differential
3	CANH short-circuited to battery	weak; note 1	on	off	on	CANL
3a	CANH short-circuited to V_{CC}	weak; note 1	on	off	on	CANL
4	CANL short-circuited to ground	on	weak; note 2	on	off	CANH
5	CANH short-circuited to ground	on	on	on	on	differential
6	CANL short-circuited to battery	on	weak; note 2	on	off	CANH
6a	CANL short-circuited to V_{CC}	on	on	on	on	differential
7	CANL and CANH mutually short-circuited	on	weak; note 2	on	off	CANH

Notes

1. A weak termination implies a pull-down current source behaviour of 75 μ A typical.
2. A weak termination implies a pull-up current source behaviour of 75 μ A typical.

Fault-tolerant CAN transceiver

TJA1054

Failure 6 is detected if the CANL bus line exceeds its comparator threshold for a certain period of time. This delay is needed to avoid false triggering by external RF fields. After detection of failure 6, the reception is switched to the single-wire mode through CANH; the CANL driver is switched off and the RTL bias changes to the pull-up current source.

Recovery from failures 3, 3a and 6 is detected automatically after reading a consecutive recessive level by corresponding comparators for a certain period of time.

Failures 4 and 7 initially result in a permanent dominant level on pin RXD. After a time-out the CANL driver is switched off and the RTL bias changes to the pull-up current source. Reception continues by switching to the single-wire mode via pins CANH or CANL. When failures 4 or 7 are removed, the recessive bus levels are restored. If the differential voltage remains below the recessive threshold level for a certain period of time, reception and transmission switch back to the differential mode.

If any of the wiring failure occurs, the output signal on pin ERR will be set to LOW. On error recovery, the output signal on pin ERR will be set to HIGH again. In case of an interrupted open bus wire, this failure will be detected and signalled only if there is an open wire between the transmitting and receiving node(s). Thus, during open wire failures, pin ERR typically toggles.

During all single-wire transmissions, EMC performance (both immunity and emission) is worse than in the differential mode. The integrated receiver filters suppress any HF noise induced into the bus wires. The cut-off frequency of these filters is a compromise between propagation delay and HF suppression. In single-wire mode, LF noise cannot be distinguished from the required signal.

Low power modes

The transceiver provides three low power modes which can be entered and exited via pins STB and EN (see Table 2 and Fig.3).

The sleep mode is the mode with the lowest power consumption. Pin INH is switched to HIGH-impedance for deactivation of the external voltage regulator. Pin CANL is biased to the battery voltage via pin RTL. If the supply voltage is provided, pins RXD and ERR will signal the wake-up interrupt.

The standby mode operates in the same way as the sleep mode but with a HIGH level on pin INH.

The power-on standby mode is the same as the standby mode, however, in this mode the battery power-on flag is shown on pin ERR instead of the wake-up interrupt signal. The output on pin RXD will show the wake-up interrupt. This mode is only for reading out the power-on flag.

Table 2 Normal operating and low power modes

MODE	PIN STB	PIN EN	PIN ERR		PIN RXD		PIN RTL SWITCHED TO
			LOW	HIGH	LOW	HIGH	
Goto-sleep command	LOW	HIGH	wake-up interrupt signal; notes 1 2 and 3		wake-up interrupt signal; notes 1 2 and 3		V _{BAT}
Sleep	LOW	LOW ⁽⁴⁾					
Standby	LOW	LOW					
Power-on standby	HIGH	LOW	V _{BAT} power-on flag; notes 1 and 5		wake-up interrupt signal; notes 1 2 and 3		V _{BAT}
Normal operating	HIGH	HIGH	error flag	no error flag	dominant received data	recessive received data	V _{CC}

Notes

1. If the supply voltage V_{CC} is present.
2. Wake-up interrupts are released when entering normal operating mode.

Fault-tolerant CAN transceiver

TJA1054

3. A local or remote wake-up event will be signalled at the transceiver pins RXD and NERR if $V_{BAT} = 5.3\text{ V}$ to 27 V .
4. In case the goto-sleep command was used before. When V_{CC} drops, pin EN will become LOW, but due to the fail-safe functionality this does not effect the internal functions.
5. V_{BAT} power-on flag will be reset when entering normal operating mode.

Wake-up requests are recognized by the transceiver through two possible channels:

- The bus lines for remote wake-up
- Pin \overline{WAKE} for local wake-up.

In order to wake-up the transceiver remotely through the bus lines, a filter mechanism is integrated. This mechanism makes sure that noise and any present bus failure conditions do not result into an erroneous wake-up. Because of this mechanism it is not sufficient to simply pull the CANH or CANL bus lines to a dominant level for a certain time. To guarantee a successful remote wake-up under all conditions, a message frame with a dominant phase of at least the maximum specified t_{CANH} or t_{CANL} in it is required.

A local wake-up through pin \overline{WAKE} is detected by a rising or falling edge with a consecutive level with the maximum specified t_{WAKE} .

On a wake-up request the transceiver will set the output on pin INH to HIGH which can be used to activate the external supply voltage regulator.

If V_{CC} is provided the wake-up request can be read on the ERR or RXD outputs, so the external microcontroller can activate the transceiver (switch to normal operating mode) via pins STB and EN.

To prevent a false remote wake-up due to transients or RF fields, the wake-up voltage levels have to be maintained for a certain period of time. In the low power modes the failure detection circuit remains partly active to prevent an increased power consumption in the event of failures 3, 3a, 4 and 7.

To prevent a false local wake-up during an open wire at pin \overline{WAKE} , this pin has a weak pull-up current source towards V_{BAT} . However, in order to prevent EMC issues, it is recommended to connect a not used pin \overline{WAKE} to pin BAT. INH is set to floating only if the goto-sleep command is entered successfully. To enter a successful goto-sleep command under all conditions, this command must be kept stable for the maximum specified $t_{h(sleep)}$.

Pin INH will be set to a HIGH level again by the following events only:

- V_{BAT} power-on (cold start)
- Rising or falling edge on pin \overline{WAKE}
- A message frame with a dominant phase of at least the maximum specified t_{CANH} or t_{CANL} , while pin EN or pin STB is at a LOW level
- Pin \overline{STB} goes to a HIGH level with V_{CC} active.

To provide fail-safe functionality, the signals on pins \overline{STB} and EN will internally be set to LOW when V_{CC} is below a certain threshold voltage ($V_{CC(stb)}$).

Power-on

After power-on (V_{BAT} switched on) the signal on pin INH will become HIGH and an internal power-on flag will be set. This flag can be read in the power-on standby mode through pin ERR ($STB = 1$; $EN = 0$) and will be reset by entering the normal operating mode.

Protections

A current limiting circuit protects the transmitter output stages against short-circuit to positive and negative battery voltage.

If the junction temperature exceeds the typical value of $165\text{ }^{\circ}\text{C}$, the transmitter output stages are disabled. Because the transmitter is responsible for the major part of the power dissipation, this will result in a reduced power dissipation and hence a lower chip temperature. All other parts of the device will continue to operate.

The pins CANH and CANL are protected against electrical transients which may occur in an automotive environment.

Fault-tolerant CAN transceiver

TJA1054

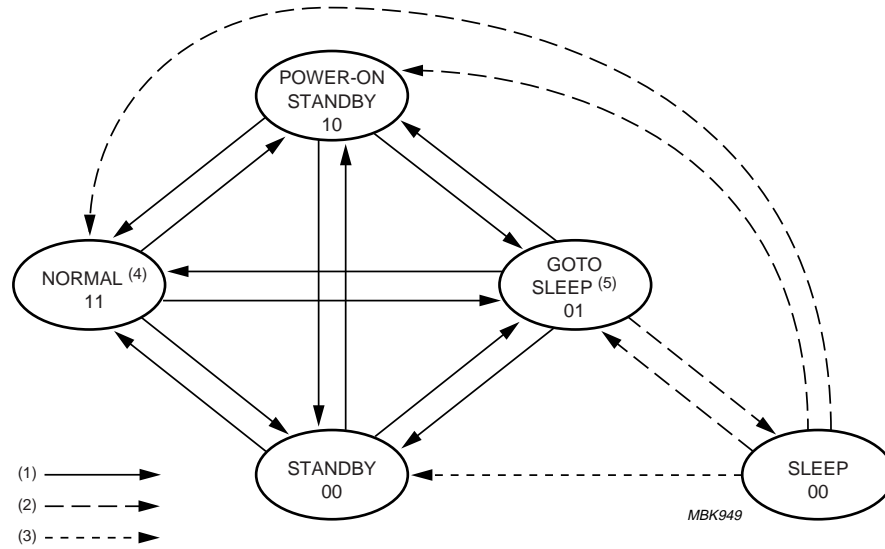

Mode 10 stands for: pin \overline{STB} = HIGH and pin EN = LOW.

- (1) Mode change via input pins \overline{STB} and EN.
- (2) Mode change via input pins \overline{STB} and EN; it should be noted that in the sleep mode pin INH is inactive and possibly there is no V_{CC} . Mode control is only possible if V_{CC} of the transceiver is active.
- (3) Pin INH is activated after wake-up via bus or input pin WAKE.
- (4) Transitions to normal mode clear the internal wake-up: interrupt and battery fail flag are cleared.
- (5) Transitions to sleep mode: pin INH is deactivated.

Fig.3 Mode control.

Fault-tolerant CAN transceiver

TJA1054

LIMITING VALUES

In accordance with the Absolute Maximum Rating System (IEC 60134); note 1.

SYMBOL	PARAMETER	CONDITIONS	MIN.	MAX.	UNIT
V _{CC}	supply voltage on pin V _{CC}		-0.3	+6	V
V _{BAT}	battery voltage on pin BAT		-0.3	+40	V
V _n	DC voltage on pins TXD, RXD, ERR, STB and EN		-0.3	V _{CC} + 0.3	V
V _{CANH}	CANH bus line voltage		-40	+40	V
V _{CANL}	CANL bus line voltage		-40	+40	V
V _{trt(n)}	transient voltage on pins CANH and CANL	see Fig.6	-150	+100	V
V _{WAKE}	DC input voltage on pin $\overline{\text{WAKE}}$		-	V _{BAT} + 0.3	V
I _{WAKE}	DC input current on pin $\overline{\text{WAKE}}$	note 2	-15	-	mA
V _{INH}	DC output voltage on pin INH		-0.3	V _{BAT} + 0.3	V
V _{RTH}	DC voltage on pin RTH		-0.3	V _{BAT} + 1.2	V
V _{RTL}	DC voltage on pin RTL		-0.3	V _{BAT} + 1.2	V
R _{RTH}	termination resistance on pin RTH		500	16000	Ω
R _{RTL}	termination resistance on pin RTL		500	16000	Ω
T _{vj}	virtual junction temperature	note 3	-40	+150	°C
T _{stg}	storage temperature		-55	+150	°C
V _{esd}	electrostatic discharge voltage	human body model; note 4	-2	+2	kV
		machine model; note 5	-175	+175	V

Notes

- All voltages are defined with respect to pin GND. Positive current flows into the device.
- Only relevant if V_{WAKE} < V_{GND} - 0.3 V; current will flow into pin GND.
- Junction temperature in accordance with IEC 60747-1. An alternative definition is: T_{vj} = T_{amb} + P × R_{th(vj-a)} where R_{th(vj-a)} is a fixed value to be used for the calculation of T_{vj}. The rating for T_{vj} limits the allowable combinations of power dissipation (P) and operating ambient temperature (T_{amb}).
- Equivalent to discharging a 100 pF capacitor through a 1.5 kΩ resistor.
- Equivalent to discharging a 200 pF capacitor through a 10 Ω resistor and a 0.75 μH coil.

THERMAL CHARACTERISTICS

SYMBOL	PARAMETER	CONDITIONS	VALUE	UNIT
R _{th(j-a)}	thermal resistance from junction to ambient	in free air	120	K/W
R _{th(j-s)}	thermal resistance from junction to substrate bare die	in free air	40	K/W

QUALITY SPECIFICATION

Quality specification in accordance with "SNW-FQ-611".

Fault-tolerant CAN transceiver

TJA1054

DC CHARACTERISTICS

$V_{CC} = 4.75$ to 5.25 V; $V_{BAT} = 5.0$ to 27 V; $V_{STB} = V_{CC}$; $T_{vj} = -40$ to $+150$ °C; all voltages are defined with respect to ground; positive currents flow into the device; unless otherwise specified; notes 1 2 and 3.

SYMBOL	PARAMETER	CONDITIONS	MIN.	TYP.	MAX.	UNIT
Supplies (pins V_{CC} and BAT)						
V_{CC}	supply voltage on pin V_{CC}		4.75	–	5.25	V
$V_{CC(stb)}$	supply voltage for forced standby mode (fail-safe)		2.75	–	4.5	V
I_{CC}	supply current	normal operating mode; $V_{TXD} = V_{CC}$ (recessive)	4	7	11	mA
		normal operating mode; $V_{TXD} = 0$ V (dominant); no load	10	17	27	mA
		low power modes; $V_{TXD} = V_{CC}$	0	0	10	μ A
V_{BAT}	battery voltage on pin BAT	no time limit	–0.3	–	+40	V
		operating mode	5.0	–	27	V
		load dump	–	–	40	V
I_{BAT}	battery current on pin BAT	all modes and in low power modes at $V_{RTL} = V_{WAKE} = V_{INH} = V_{BAT}$ $V_{BAT} = 12$ V $V_{BAT} = 5.0$ to 27 V $V_{BAT} = 3.5$ V $V_{BAT} = 1$ V	10	30	50	μ A
			5	30	125	μ A
			5	20	30	μ A
			0	0	10	μ A
$V_{BAT(Pwon)}$	power-on flag voltage on pin BAT	low power modes power-on flag set	–	–	1	V
		power-on flag not set	3.5	–	–	V
I_{tot}	supply current plus battery current	low power modes; $V_{CC} = 5$ V; $V_{BAT} = V_{WAKE} = V_{INH} = 12$ V	–	30	60	μ A
Pins STB, EN and TXD						
V_{IH}	HIGH-level input voltage		$0.7V_{CC}$	–	$V_{CC} + 0.3$	V
V_{IL}	LOW-level input voltage		–0.3	–	$0.3V_{CC}$	V
I_{IH}	HIGH-level input current pins \overline{STB} and EN pin TXD	$V_I = 4$ V	–	9	20	μ A
			–200	–80	–25	μ A
I_{IL}	LOW-level input current pins \overline{STB} and EN pin TXD	$V_I = 1$ V	4	8	–	μ A
			–800	–320	–100	μ A

Fault-tolerant CAN transceiver

TJA1054

SYMBOL	PARAMETER	CONDITIONS	MIN.	TYP.	MAX.	UNIT
Pins RXD and ERR						
V _{OH}	HIGH-level output voltage on pin $\overline{\text{ERR}}$ on pin RXD	I _O = -100 μA	V _{CC} - 0.9	-	V _{CC}	V
		I _O = -1 mA	V _{CC} - 0.9	-	V _{CC}	V
V _{OL}	LOW-level output voltage on pins $\overline{\text{ERR}}$ and RXD	I _O = 1.6 mA	0	-	0.4	V
		I _O = 7.5 mA	0	-	1.5	V
Pin $\overline{\text{WAKE}}$						
I _{IL}	LOW-level input current	V _{WAKE} = 0 V; V _{BAT} = 27 V	-10	-4	-1	μA
V _{th(wake)}	wake-up threshold voltage	V _{STB} = 0 V	2.5	3.2	3.9	V
Pin INH						
ΔV_H	HIGH-level voltage drop	I _{INH} = -0.18 mA	-	-	0.8	V
I _L	leakage current	sleep mode; V _{INH} = 0 V	-	-	5	μA
Pins CANH and CANL						
V _{th(dif)}	differential receiver threshold voltage	no failures and bus failures 1, 2, 5 and 6a; see Fig.4				
		V _{CC} = 5 V	-3.5	-3.2	-2.9	V
		V _{CC} = 4.75 to 5.25 V	-0.70V _{CC}	-0.64V _{CC}	-0.58V _{CC}	V
V _{O(reces)}	recessive output voltage on pin CANH on pin CANL	V _{TXD} = V _{CC}	-	-	0.2	V
		R _{RTH} < 4 k Ω R _{RTL} < 4 k Ω	V _{CC} - 0.2	-	-	V
V _{O(dom)}	dominant output voltage on pin CANH on pin CANL	V _{TXD} = 0 V; V _{EN} = V _{CC}	V _{CC} - 1.4	-	-	V
		I _{CANH} = -40 mA I _{CANL} = 40 mA	-	-	1.4	V
I _{O(CANH)}	output current on pin CANH	normal operating mode; V _{CANH} = 0 V; V _{TXD} = 0 V	-110	-80	-45	mA
		low power modes; V _{CANH} = 0 V; V _{CC} = 5 V	-	-0.25	-	μA
I _{O(CANL)}	output current on pin CANL	normal operating mode; V _{CANL} = 14 V; V _{TXD} = 0 V	45	70	100	mA
		low power modes; V _{CANL} = 12 V; V _{BAT} = 12 V	-	0	-	μA
V _{d(CANH)(sc)}	detection voltage for short-circuit to battery voltage on pin CANH	normal operating mode	1.5	1.7	1.85	V
		low power modes	1.1	1.8	2.5	V
V _{d(CANL)(sc)}	detection voltage for short-circuit to battery voltage on pin CANL	normal operating mode				
		V _{CC} = 5 V	6.6	7.2	7.8	V
		V _{CC} = 4.75 to 5.25 V	1.32V _{CC}	1.44V _{CC}	1.56V _{CC}	V
V _{th(wake)}	wake-up threshold voltage on pin CANL on pin CANH	low power modes	2.5	3.2	3.9	V
		low power modes	1.1	1.8	2.5	V

Fault-tolerant CAN transceiver

TJA1054

SYMBOL	PARAMETER	CONDITIONS	MIN.	TYP.	MAX.	UNIT
$\Delta V_{th(wake)}$	difference of wake-up threshold voltages	low power modes	0.8	1.4	–	V
$V_{th(CANH)(se)}$	single-ended receiver threshold voltage on pin CANH	normal operating mode and failures 4, 6 and 7 $V_{CC} = 5\text{ V}$ $V_{CC} = 4.75\text{ to }5.25\text{ V}$	1.5 $0.30V_{CC}$	1.7 $0.34V_{CC}$	1.85 $0.37V_{CC}$	V V
$V_{th(CANL)(se)}$	single-ended receiver threshold voltage on pin CANL	normal operating mode and failures 3 and 3a $V_{CC} = 5\text{ V}$ $V_{CC} = 4.75\text{ to }5.25\text{ V}$	3.15 $0.63V_{CC}$	3.3 $0.66V_{CC}$	3.45 $0.69V_{CC}$	V V
$R_{i(CANH)(se)}$	single-ended input resistance on pin CANH	normal operating mode	110	165	270	k Ω
$R_{i(CANL)(se)}$	single-ended input resistance on pin CANL	normal operating mode	110	165	270	k Ω
$R_{i(dif)}$	differential input resistance	normal operating mode	220	330	540	k Ω
Pins RTH and RTL						
$R_{sw(RTL)}$	switch-on resistance between pin RTL and V_{CC}	normal operating mode; $ I_O < 10\text{ mA}$	–	50	100	Ω
$R_{sw(RTH)}$	switch-on resistance between pin RTH and ground	normal operating mode; $ I_O < 10\text{ mA}$	–	50	100	Ω
$V_{O(RTH)}$	output voltage on pin RTH	low power modes; $I_O = 1\text{ mA}$	–	0.7	1.0	V
$I_{O(RTL)}$	output current on pin RTL	low power modes; $V_{RTL} = 0\text{ V}$	–1.25	–0.65	–0.3	mA
$I_{pu(RTL)}$	pull-up current on pin RTL	normal operating mode and failures 4, 6 and 7	–	75	–	μA
$I_{pd(RTH)}$	pull-down current on pin RTH	normal operating mode and failures 3 and 3a	–	75	–	μA
Thermal shutdown						
$T_{j(sd)}$	junction temperature for shutdown		155	165	180	$^{\circ}\text{C}$

Notes

- All parameters are guaranteed over the virtual junction temperature range by design, but only 100% tested at $T_{amb} = 125\text{ }^{\circ}\text{C}$ for dies on wafer level, and above this for cased products 100% tested at $T_{amb} = 25\text{ }^{\circ}\text{C}$, unless otherwise specified.
- For bare die, all parameters are only guaranteed if the back side of the die is connected to ground.
- A local or remote wake-up event will be signalled at the transceiver pins RXD and NERR if $V_{BAT} = 5.3\text{ V to }27\text{ V}$ (see Table 2).

Fault-tolerant CAN transceiver

TJA1054

TIMING CHARACTERISTICS

$V_{CC} = 4.75$ to 5.25 V; $V_{BAT} = 5.0$ to 27 V; $V_{STB} = V_{CC}$; $T_{vj} = -40$ to $+150$ °C; all voltages are defined with respect to ground; unless otherwise specified; notes 1 2 and 3.

SYMBOL	PARAMETER	CONDITIONS	MIN.	TYP.	MAX.	UNIT
$t_{t(r-d)}$	CANL and CANH output transition time for recessive to dominant	between 10% and 90%; R1 = 100 Ω ; C1 = 10 nF; C2 = not present; see Fig.5	0.35	0.60	–	μ s
$t_{t(d-r)}$	CANL and CANH output transition time for dominant to recessive	between 10% and 90%; R1 = 100 Ω ; C1 = 1 nF; C2 = not present; see Fig.5	0.2	0.3	–	μ s
$t_{PD(L)}$	propagation delay TXD (LOW) to RXD (LOW)	no failures and failures 1, 2, 5 and 6a; R1 = 100 Ω ; see Figs 4 and 5 C1 = 1 nF; C2 = not present	–	0.75	1.5	μ s
		C1 = C2 = 3.3 nF	–	1	1.75	μ s
		failures 3, 3a, 4, 6 and 7; R1 = 100 Ω ; see Figs 4 and 5 C1 = 1 nF; C2 = not present	–	0.85	1.4	μ s
C1 = C2 = 3.3 nF	–	1.1	1.7	μ s		
$t_{PD(H)}$	propagation delay TXD (HIGH) to RXD (HIGH)	no failures and failures 1, 2, 5 and 6a; R1 = 100 Ω ; see Figs 4 and 5 C1 = 1 nF; C2 = not present	–	1.2	1.9	μ s
		C1 = C2 = 3.3 nF	–	2.5	3.3	μ s
		failures 3, 3a, 4, 6 and 7; R1 = 100 Ω ; see Figs 4 and 5 C1 = 1 nF; C2 = not present	–	1.1	1.7	μ s
C1 = C2 = 3.3 nF	–	1.5	2.2	μ s		
$t_{react(sleep)}$	reaction time of goto-sleep command	note 4	5	–	50	μ s
$t_{dis(TxD)}$	disable time of TxD permanent dominant timer	normal operating mode; $V_{TxD} = 0$ V	0.75	–	4	ms
t_{CANH}	dominant time for remote wake-up on pin CANH	low power modes; $V_{BAT} = 12$ V; note 4	7	–	38	μ s
t_{CANL}	dominant time for remote wake-up on pin CANL	low power modes; $V_{BAT} = 12$ V; note 4	7	–	38	μ s
t_{WAKE}	required time on pin \overline{WAKE} for local wake-up	low power modes; $V_{BAT} = 12$ V; for wake-up after receiving a falling or rising edge; note 4	7	–	38	μ s
t_{det}	failure detection time	normal operating mode				
		failures 3 and 3a	1.6	–	8.0	ms
		failures 4, 6 and 7	0.3	–	1.6	ms
	low power modes; $V_{BAT} = 12$ V					
	failures 3 and 3a	1.6	–	8.0	ms	
	failures 4 and 7	0.1	–	1.6	ms	

Fault-tolerant CAN transceiver

TJA1054

SYMBOL	PARAMETER	CONDITIONS	MIN.	TYP.	MAX.	UNIT
t_{rec}	failure recovery time	normal operating mode				
		failures 3 and 3a	0.3	–	1.6	ms
		failures 4 and 7	7	–	38	μ s
		failure 6	125	–	750	μ s
		low power modes; $V_{BAT} = 12$ V				
		failures 3, 3a, 4 and 7	0.3	–	1.6	ms
N_{det}	pulse-count difference between CANH and CANL for failure detection	normal operating mode and failures 1, 2, 5 and 6a; pin ERR becomes LOW	–	4	–	
N_{rec}	number of consecutive pulses on CANH and CANL simultaneously for failure recovery	failures 1, 2, 5 and 6a	–	4	–	

Notes

1. All parameters are guaranteed over the virtual junction temperature range by design, but only 100% tested at $T_{amb} = 125$ °C for dies on wafer level, and above this for cased products 100% tested at $T_{amb} = 25$ °C, unless otherwise specified.
2. For bare die, all parameters are only guaranteed if the back side of the die is connected to ground.
3. A local or remote wake-up event will be signalled at the transceiver pins RXD and NERR if $V_{BAT} = 5.3$ V to 27 V (see Table 2).
4. To guarantee a successful mode transition under all conditions, the maximum specified time must be applied.

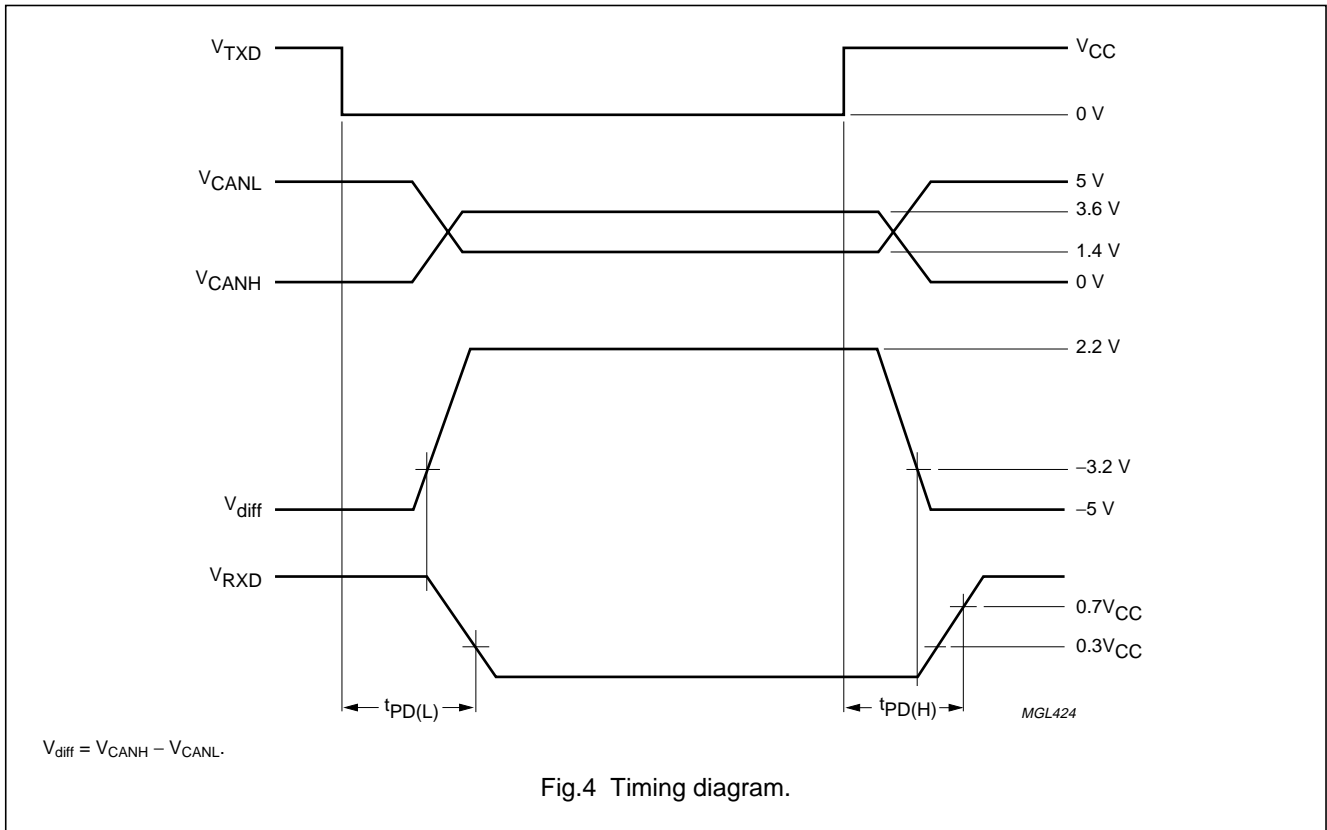

Fault-tolerant CAN transceiver

TJA1054

TEST AND APPLICATION INFORMATION

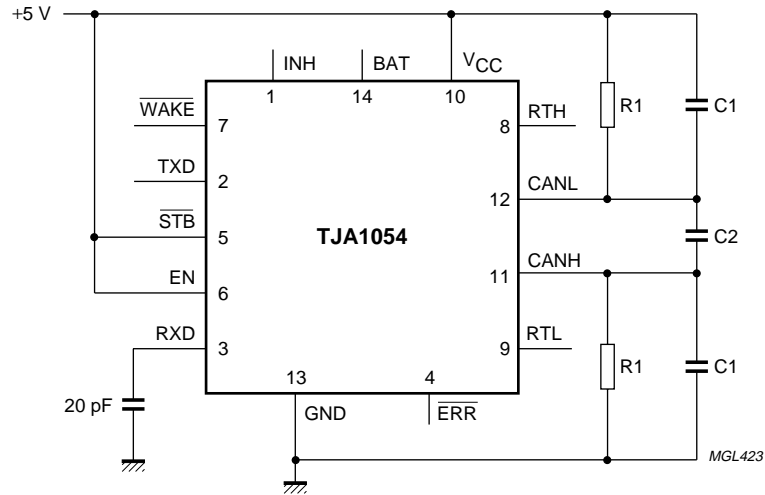

Termination resistors R1 (100 Ω) are not connected to pin RTH or pin RTL for testing purposes because the minimum load allowed on the CAN bus lines is 500 Ω per transceiver.
 The capacitive bus load of 10 nF is split into 3 equal capacitors (3.3 nF) to simulate the bus cable.

Fig.5 Test circuit for dynamic characteristics.

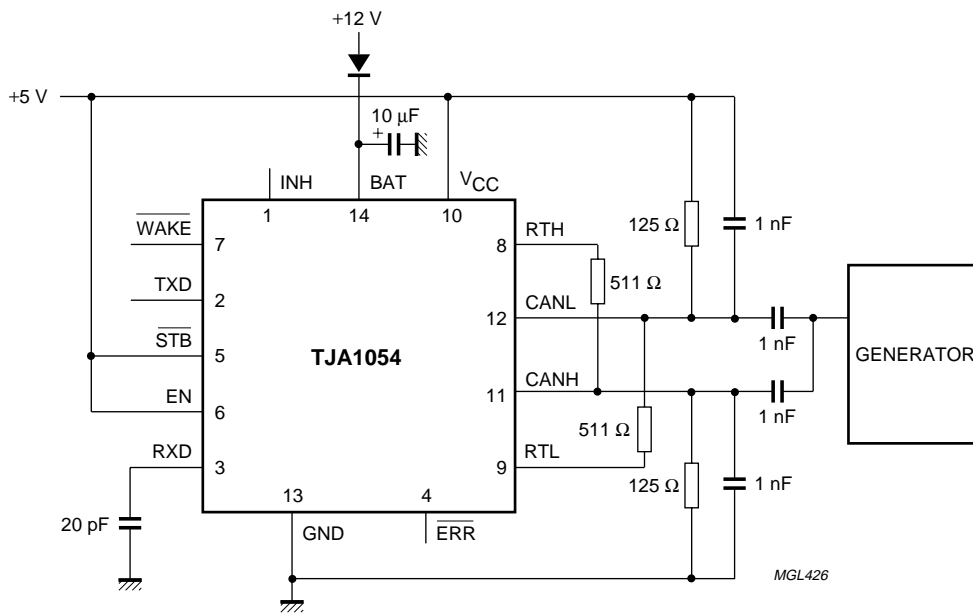

The waveforms of the applied transients on pins CANH and CANL will be in accordance with ISO 7637 part 1: test pulses 1, 2, 3a and 3b.

Fig.6 Test circuit for automotive transients.

Fault-tolerant CAN transceiver

TJA1054

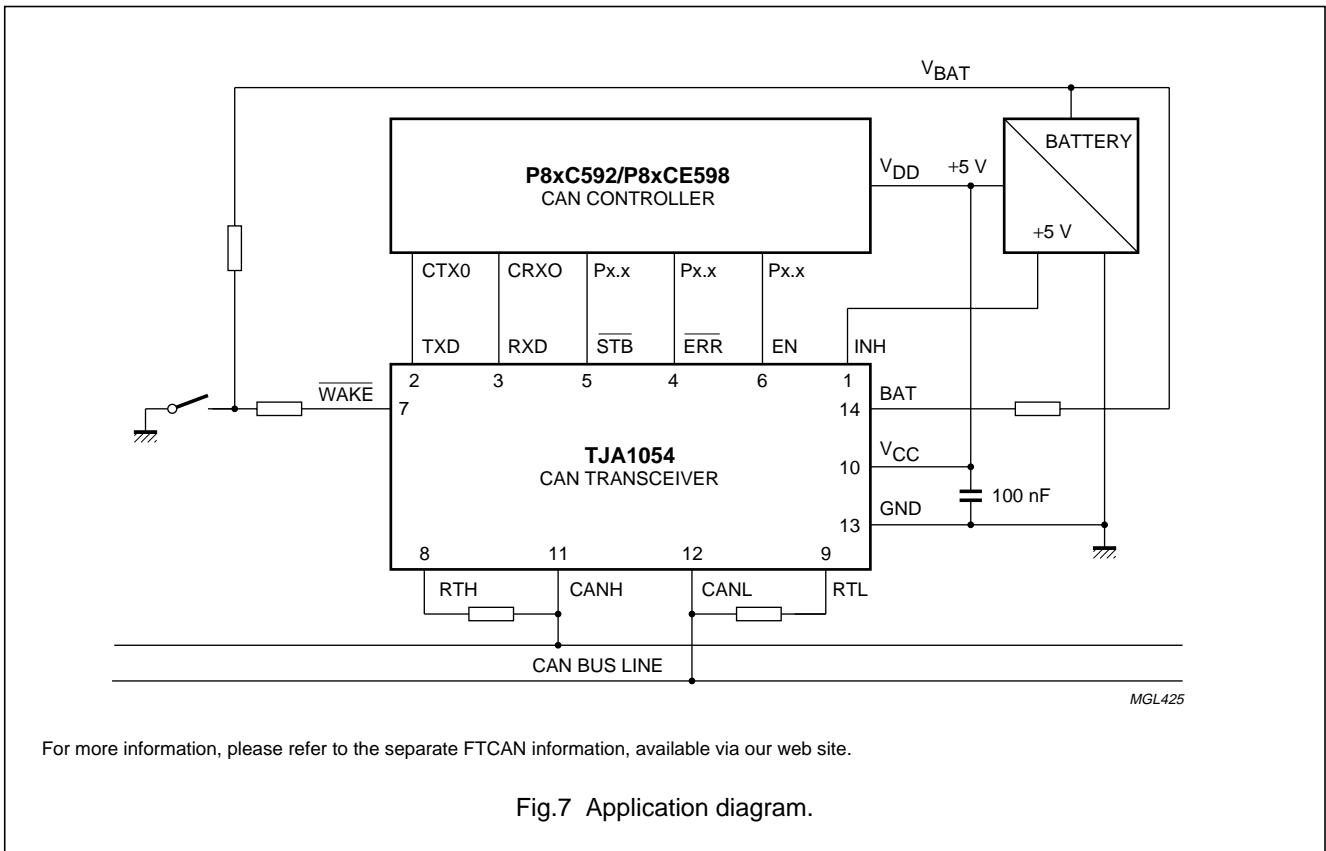

Fault-tolerant CAN transceiver

TJA1054

BONDING PAD LOCATIONS

SYMBOL	PAD	COORDINATES ⁽¹⁾	
		x	y
INH	1	106	317
TXD	2	111	169
RXD	3	750	111
ERR	4	1347	111
STB	5	2248	103
EN	6	2521	240
WAKE	7	2521	381
RTH	8	2550	1269
RTL	9	2359	1840
V _{CC}	10	1886	1809
CANH	11	872	1840
CANL	12	437	1840
GND	13a	80	1356
GND	13b	80	1241
BAT	14	106	772

Note

1. All coordinates (μm) represent the position of the centre of each pad with respect to the bottom left-hand corner of the top aluminium layer (see Fig.8).

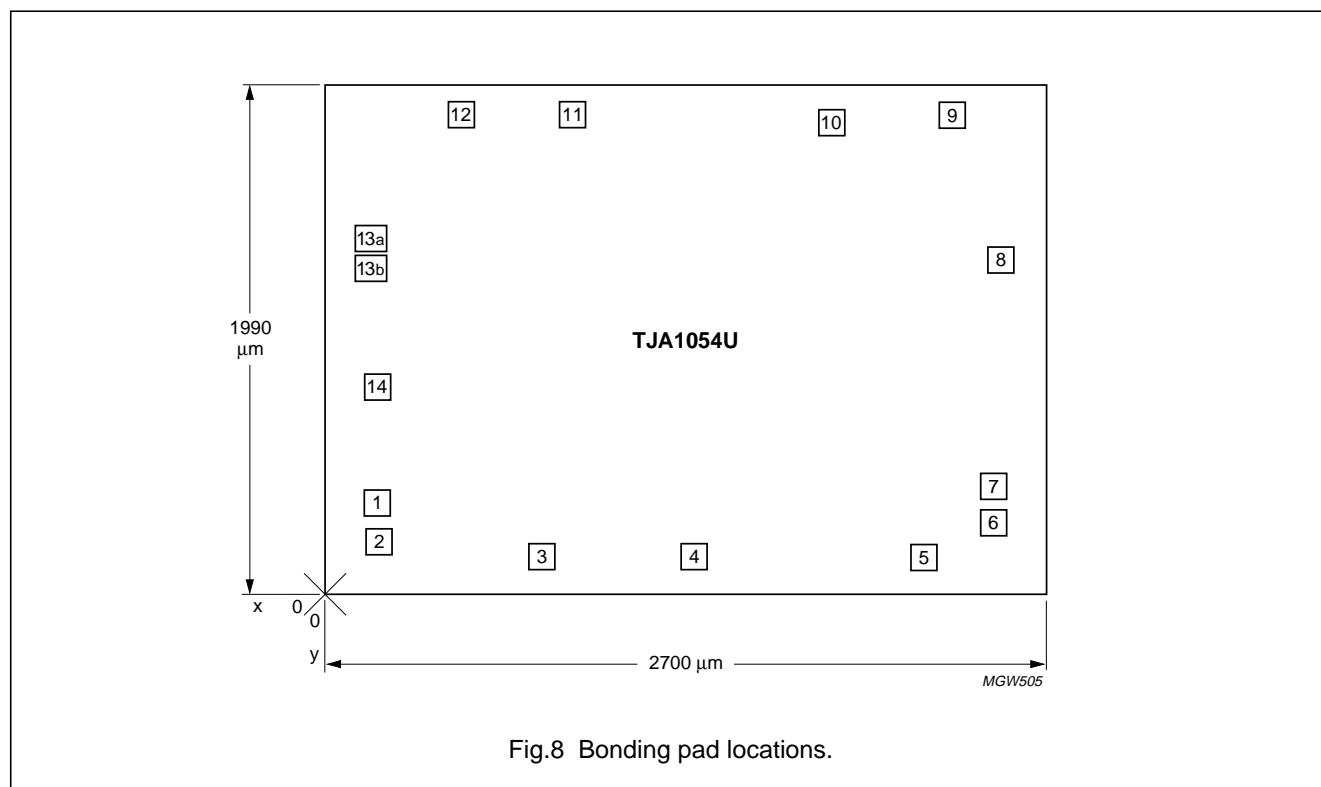

Fig.8 Bonding pad locations.

Fault-tolerant CAN transceiver

TJA1054

PACKAGE OUTLINE

SO14: plastic small outline package; 14 leads; body width 3.9 mm

SOT108-1

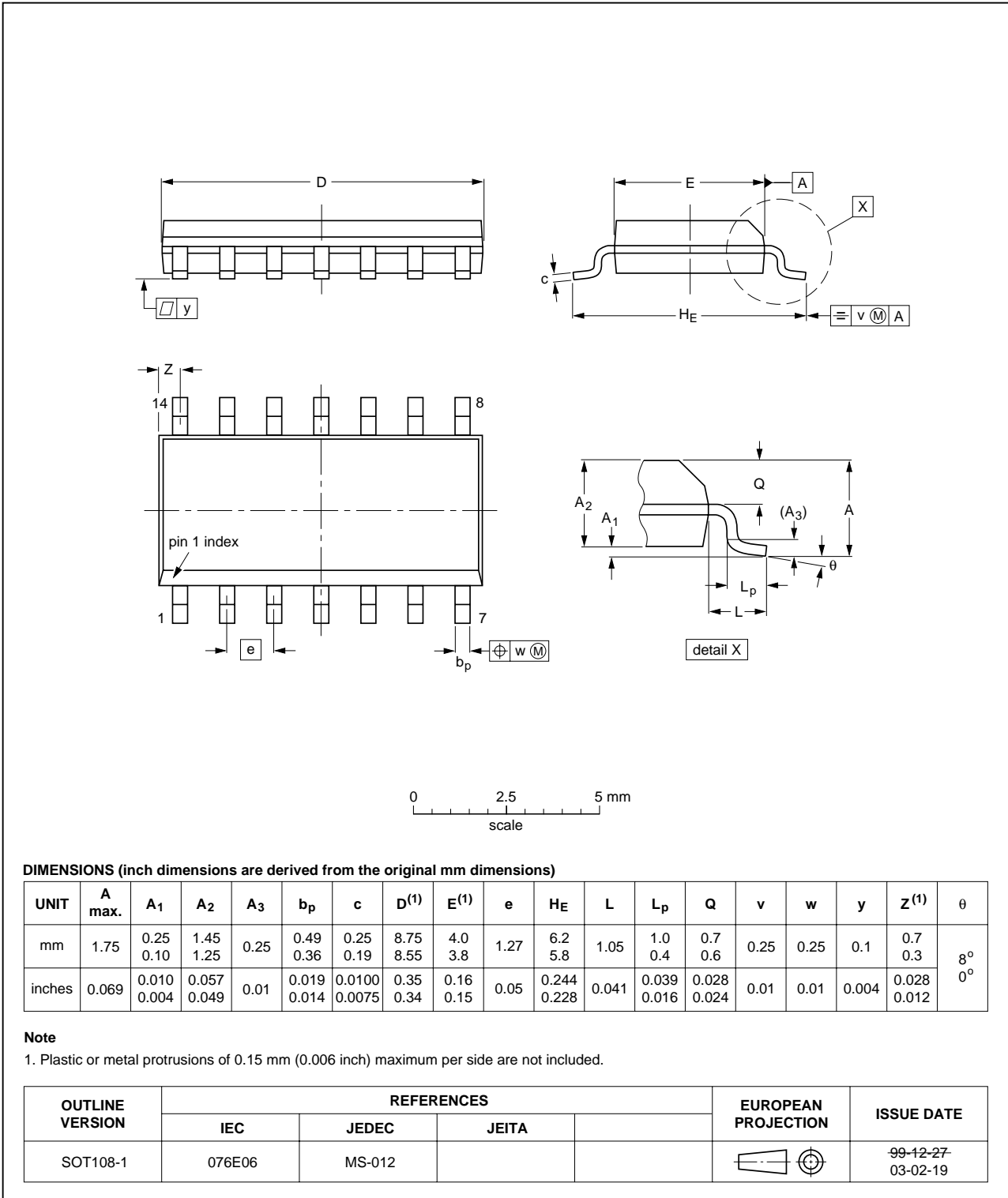

Fault-tolerant CAN transceiver

TJA1054

SOLDERING

Introduction to soldering surface mount packages

This text gives a very brief insight to a complex technology. A more in-depth account of soldering ICs can be found in our *"Data Handbook IC26; Integrated Circuit Packages"* (document order number 9398 652 90011).

There is no soldering method that is ideal for all surface mount IC packages. Wave soldering can still be used for certain surface mount ICs, but it is not suitable for fine pitch SMDs. In these situations reflow soldering is recommended.

Reflow soldering

Reflow soldering requires solder paste (a suspension of fine solder particles, flux and binding agent) to be applied to the printed-circuit board by screen printing, stencilling or pressure-syringe dispensing before package placement. Driven by legislation and environmental forces the worldwide use of lead-free solder pastes is increasing.

Several methods exist for reflowing; for example, convection or convection/infrared heating in a conveyor type oven. Throughput times (preheating, soldering and cooling) vary between 100 and 200 seconds depending on heating method.

Typical reflow peak temperatures range from 215 to 270 °C depending on solder paste material. The top-surface temperature of the packages should preferably be kept:

- below 225 °C (SnPb process) or below 245 °C (Pb-free process)
 - for all BGA, HTSSON-T and SSOP-T packages
 - for packages with a thickness ≥ 2.5 mm
 - for packages with a thickness < 2.5 mm and a volume ≥ 350 mm³ so called thick/large packages.
- below 240 °C (SnPb process) or below 260 °C (Pb-free process) for packages with a thickness < 2.5 mm and a volume < 350 mm³ so called small/thin packages.

Moisture sensitivity precautions, as indicated on packing, must be respected at all times.

Wave soldering

Conventional single wave soldering is not recommended for surface mount devices (SMDs) or printed-circuit boards with a high component density, as solder bridging and non-wetting can present major problems.

To overcome these problems the double-wave soldering method was specifically developed.

If wave soldering is used the following conditions must be observed for optimal results:

- Use a double-wave soldering method comprising a turbulent wave with high upward pressure followed by a smooth laminar wave.
- For packages with leads on two sides and a pitch (e):
 - larger than or equal to 1.27 mm, the footprint longitudinal axis is **preferred** to be parallel to the transport direction of the printed-circuit board;
 - smaller than 1.27 mm, the footprint longitudinal axis **must** be parallel to the transport direction of the printed-circuit board.

The footprint must incorporate solder thieves at the downstream end.

- For packages with leads on four sides, the footprint must be placed at a 45° angle to the transport direction of the printed-circuit board. The footprint must incorporate solder thieves downstream and at the side corners.

During placement and before soldering, the package must be fixed with a droplet of adhesive. The adhesive can be applied by screen printing, pin transfer or syringe dispensing. The package can be soldered after the adhesive is cured.

Typical dwell time of the leads in the wave ranges from 3 to 4 seconds at 250 °C or 265 °C, depending on solder material applied, SnPb or Pb-free respectively.

A mildly-activated flux will eliminate the need for removal of corrosive residues in most applications.

Manual soldering

Fix the component by first soldering two diagonally-opposite end leads. Use a low voltage (24 V or less) soldering iron applied to the flat part of the lead. Contact time must be limited to 10 seconds at up to 300 °C.

When using a dedicated tool, all other leads can be soldered in one operation within 2 to 5 seconds between 270 and 320 °C.

Fault-tolerant CAN transceiver

TJA1054

Suitability of surface mount IC packages for wave and reflow soldering methods

PACKAGE ⁽¹⁾	SOLDERING METHOD	
	WAVE	REFLOW ⁽²⁾
BGA, HTSSON..T ⁽³⁾ , LBGA, LFBGA, SQFP, SSOP..T ⁽³⁾ , TFBGA, USON, VFBGA	not suitable	suitable
DHVQFN, HBCC, HBGA, HLQFP, HSO, HSOP, HSQFP, HSSON, HTQFP, HTSSOP, HVQFN, HVSON, SMS	not suitable ⁽⁴⁾	suitable
PLCC ⁽⁵⁾ , SO, SOJ	suitable	suitable
LQFP, QFP, TQFP	not recommended ⁽⁵⁾⁽⁶⁾	suitable
SSOP, TSSOP, VSO, VSSOP	not recommended ⁽⁷⁾	suitable
CWQCCN..L ⁽⁸⁾ , PMFP ⁽⁹⁾ , WQCCN..L ⁽⁸⁾	not suitable	not suitable

Notes

- For more detailed information on the BGA packages refer to the “(LF)BGA Application Note” (AN01026); order a copy from your Philips Semiconductors sales office.
- All surface mount (SMD) packages are moisture sensitive. Depending upon the moisture content, the maximum temperature (with respect to time) and body size of the package, there is a risk that internal or external package cracks may occur due to vaporization of the moisture in them (the so called popcorn effect). For details, refer to the Drypack information in the “Data Handbook IC26; Integrated Circuit Packages; Section: Packing Methods”.
- These transparent plastic packages are extremely sensitive to reflow soldering conditions and must on no account be processed through more than one soldering cycle or subjected to infrared reflow soldering with peak temperature exceeding $217\text{ °C} \pm 10\text{ °C}$ measured in the atmosphere of the reflow oven. The package body peak temperature must be kept as low as possible.
- These packages are not suitable for wave soldering. On versions with the heatsink on the bottom side, the solder cannot penetrate between the printed-circuit board and the heatsink. On versions with the heatsink on the top side, the solder might be deposited on the heatsink surface.
- If wave soldering is considered, then the package must be placed at a 45° angle to the solder wave direction. The package footprint must incorporate solder thieves downstream and at the side corners.
- Wave soldering is suitable for LQFP, TQFP and QFP packages with a pitch (e) larger than 0.8 mm; it is definitely not suitable for packages with a pitch (e) equal to or smaller than 0.65 mm.
- Wave soldering is suitable for SSOP, TSSOP, VSO and VSSOP packages with a pitch (e) equal to or larger than 0.65 mm; it is definitely not suitable for packages with a pitch (e) equal to or smaller than 0.5 mm.
- Image sensor packages in principle should not be soldered. They are mounted in sockets or delivered pre-mounted on flex foil. However, the image sensor package can be mounted by the client on a flex foil by using a hot bar soldering process. The appropriate soldering profile can be provided on request.
- Hot bar or manual soldering is suitable for PMFP packages.

Fault-tolerant CAN transceiver

TJA1054

REVISION HISTORY

REV	DATE	CPCN	DESCRIPTION
3	20040323	200310013C	Product specification (9397 750 11721) Modification: <ul style="list-style-type: none"> • Add $V_{BAT} = 5.3\text{ V}$ to 27 V condition for correct signalling of local or remote wake-up event at transceiver pins RXD and \overline{ERR}. • Mode control diagram, Fig.3, completed. • Recommendation added, to connect a not used pin \overline{WAKE} to pin BAT. • Reference of bond pad coordinates changed from the bottom left-hand corner of the die, to the bottom left-hand corner of the top aluminium layer. • Change of bare die dimension. • Add Chapter REVISION HISTORY.
2	20011120	–	Product specification (9397 750 08965)

DATA SHEET STATUS

LEVEL	DATA SHEET STATUS ⁽¹⁾	PRODUCT STATUS ⁽²⁾⁽³⁾	DEFINITION
I	Objective data	Development	This data sheet contains data from the objective specification for product development. Philips Semiconductors reserves the right to change the specification in any manner without notice.
II	Preliminary data	Qualification	This data sheet contains data from the preliminary specification. Supplementary data will be published at a later date. Philips Semiconductors reserves the right to change the specification without notice, in order to improve the design and supply the best possible product.
III	Product data	Production	This data sheet contains data from the product specification. Philips Semiconductors reserves the right to make changes at any time in order to improve the design, manufacturing and supply. Relevant changes will be communicated via a Customer Product/Process Change Notification (CPCN).

Notes

1. Please consult the most recently issued data sheet before initiating or completing a design.
2. The product status of the device(s) described in this data sheet may have changed since this data sheet was published. The latest information is available on the Internet at URL <http://www.semiconductors.philips.com>.
3. For data sheets describing multiple type numbers, the highest-level product status determines the data sheet status.

Fault-tolerant CAN transceiver

TJA1054

DEFINITIONS

Short-form specification — The data in a short-form specification is extracted from a full data sheet with the same type number and title. For detailed information see the relevant data sheet or data handbook.

Limiting values definition — Limiting values given are in accordance with the Absolute Maximum Rating System (IEC 60134). Stress above one or more of the limiting values may cause permanent damage to the device. These are stress ratings only and operation of the device at these or at any other conditions above those given in the Characteristics sections of the specification is not implied. Exposure to limiting values for extended periods may affect device reliability.

Application information — Applications that are described herein for any of these products are for illustrative purposes only. Philips Semiconductors make no representation or warranty that such applications will be suitable for the specified use without further testing or modification.

DISCLAIMERS

Life support applications — These products are not designed for use in life support appliances, devices, or systems where malfunction of these products can reasonably be expected to result in personal injury. Philips Semiconductors customers using or selling these products for use in such applications do so at their own risk and agree to fully indemnify Philips Semiconductors for any damages resulting from such application.

Right to make changes — Philips Semiconductors reserves the right to make changes in the products - including circuits, standard cells, and/or software - described or contained herein in order to improve design and/or performance. When the product is in full production (status 'Production'), relevant changes will be communicated via a Customer Product/Process Change Notification (CPCN). Philips Semiconductors assumes no responsibility or liability for the use of any of these products, conveys no licence or title under any patent, copyright, or mask work right to these products, and makes no representations or warranties that these products are free from patent, copyright, or mask work right infringement, unless otherwise specified.

Bare die — All die are tested and are guaranteed to comply with all data sheet limits up to the point of wafer sawing for a period of ninety (90) days from the date of Philips' delivery. If there are data sheet limits not guaranteed, these will be separately indicated in the data sheet. There are no post packing tests performed on individual die or wafer. Philips Semiconductors has no control of third party procedures in the sawing, handling, packing or assembly of the die. Accordingly, Philips Semiconductors assumes no liability for device functionality or performance of the die or systems after third party sawing, handling, packing or assembly of the die. It is the responsibility of the customer to test and qualify their application in which the die is used.

Philips Semiconductors – a worldwide company

Contact information

For additional information please visit <http://www.semiconductors.philips.com>. Fax: +31 40 27 24825

For sales offices addresses send e-mail to: sales.addresses@www.semiconductors.philips.com.

© Koninklijke Philips Electronics N.V. 2004

SCA76

All rights are reserved. Reproduction in whole or in part is prohibited without the prior written consent of the copyright owner.

The information presented in this document does not form part of any quotation or contract, is believed to be accurate and reliable and may be changed without notice. No liability will be accepted by the publisher for any consequence of its use. Publication thereof does not convey nor imply any license under patent- or other industrial or intellectual property rights.

Printed in The Netherlands

R16/03/pp24

Date of release: 2004 Mar 23

Document order number: 9397 750 11721

Let's make things better.

**Philips
Semiconductors**



PHILIPS