

FEATURES

- 72-pin industry standard 4-byte single-in-line memory module
- JEDEC compliant: 21-C, Fig. 4-18 A,B (Release 6); No.95 MO-116
- Supports 90°, 40° and 22.5° connectors
- High performance, CMOS
- Single 5V ± 10% power supply
- TTL-compatible inputs and outputs
- EXTENDED DATA OUT (EDO) MODE access cycle
- Refresh modes: RAS-ONLY, CAS-BEFORE-RAS, HIDDEN
- Refresh: 2048 refresh cycles every 32 ms
- Dimensions: 4.25" (length) x 1.00" (height) x 0.360" (max thickness)

PERFORMANCE RANGE

SYMBOL	PARAMETER	Rating	
		60 ns	70 ns
t _{RAC}	RAS Access Time	60 ns (max)	70 ns (max)
t _{CAC}	CAS Access Time	15 ns (max)	20 ns (max)
t _{AA}	Access Time from Column Address	30 ns (max)	35 ns (max)
t _{RC}	Random Read or Write Cycle Time	104 ns (min)	124 ns (min)
t _{HPC}	EDO Mode Cycle Time	25 ns (min)	30 ns (min)

ORDERING INFORMATION

DESCRIPTION	PART NUMBER	ENGINEERING DESCRIPTOR
8M x 32, 60 ns, Gold Tabs, SOJ	20023C	CL001E08325B0DJ-60
8M x 32, 60 ns, Gold Tabs, TSOP	20551C	CL001E08325B0DT-60
8M x 32, 60 ns, Tin/Lead Tabs, SOJ	12000C	CL001D08325B0DJ-60
8M x 32, 60 ns, Tin/Lead Tabs, TSOP	20552C	CL001D08325B0DT-60
8M x 32, 70 ns, Gold Tabs, SOJ	20553C	CL001E08325B0DJ-70
8M x 32, 70 ns, Gold Tabs, TSOP	20554C	CL001E08325B0DT-70
8M x 32, 70 ns, Tin/Lead Tabs, SOJ	20555C	CL001D08325B0DJ-70
8M x 32, 70 ns, Tin/Lead Tabs, TSOP	20556C	CL001D08325B0DT-70
8M x 32, 60 ns, Gold Tabs, SOJ	20084C	CL001E08325B0EJ-60
8M x 32, 60 ns, Tin/Lead Tabs, SOJ	20073C	CL001D08325B0EJ-60
8M x 32, 70 ns, Gold Tabs, SOJ	20086C	CL001E08325B0EJ-70
8M x 32, 70 ns, Tin/Lead Tabs, SOJ	20087C	CL001D08325B0EJ-70

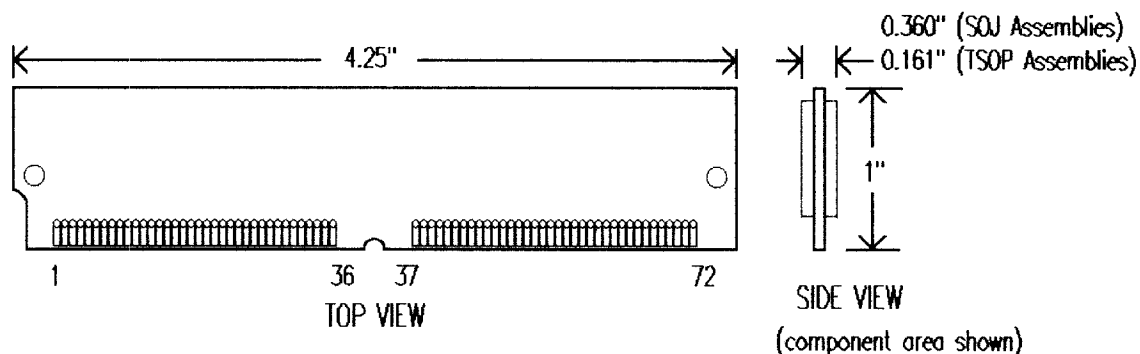
CARD OUTLINE

GENERAL DESCRIPTION

The 8M x 32 SIMM uses EDO dynamic RAM devices and is designed for use as a general-purpose 4-byte wide memory assembly with 8 data bits per byte. The SIMM is populated with sixteen 4M x 4 DRAMs.

Presence Detect (PD) bits provide information about SIMM density, addressing, performance and features.

During Read or Write Cycles, each byte may be uniquely addressed via 22 address bits, with the first eleven bits (A0~A10) latched on \overline{RAS} and the latter eleven bits (A0~A10) latched on \overline{CAS} . READ or WRITE cycles are selected with the \overline{WE} input, with a logic low indicating a WRITE cycle and a logic HIGH indicating a READ cycle. During a WRITE cycle, data-in is latched by the falling edge of \overline{WE} or \overline{CAS} , whichever occurs last.

EXTENDED DATA OUT (EDO) MODE operation allows for faster READs or WRITEs within a row-address-defined page boundary. EDO MODE is an enhanced FAST PAGE MODE method of operation. Because data output time is extended, the \overline{CAS} cycle can be shorter than it is for FAST PAGE MODE. This allows for a reduction in READ or WRITE cycle time. An EDO MODE cycle is initiated with \overline{RAS} followed by \overline{CAS} , then strobing \overline{CAS} to latch different column addresses while holding \overline{RAS} LOW.

Returning \overline{RAS} and \overline{CAS} high terminates a memory cycle and returns the DRAMs to a reduced-current STANDBY state.

Memory cell data is retained in its correct state by maintaining power and executing any \overline{RAS} cycle (READ, WRITE) or \overline{RAS} refresh cycle (\overline{RAS} -ONLY, CBR, or HIDDEN) so that all 2048 combinations of \overline{RAS} addresses (A0~A10) are executed at least every 32 ms. The CBR refresh and HIDDEN refresh cycles will invoke the on-chip refresh address counters for automatic \overline{RAS} addressing.

PIN DESCRIPTION

RAS0~RAS3	Row Address Strobe
CAS0~CAS3	Column Address Strobe
WE	Write Enable
A0~A10	Address Inputs
DQ0~7,DQ9~16, DQ18~25,DQ27~34	Data In/Out
VCC	Power (+5.0V)
VSS	Ground
NC	No Connection
PD1~4	Presence Detects

PRESENCE DETECT

PIN SYMBOL	CONFIGURATION	
	60 ns	70 ns
PD1	NC	NC
PD2	VSS	VSS
PD3	NC	VSS
PD4	NC	NC

PIN CONFIGURATION

#	Name	#	Name	#	Name	#	Name	#	Name	#	Name
1	VSS	13	A1	25	DQ24	37	NC	49	DQ9	61	DQ14
2	DQ0	14	A2	26	DQ7	38	NC	50	DQ27	62	DQ33
3	DQ18	15	A3	27	DQ25	39	VSS	51	DQ10	63	DQ15
4	DQ1	16	A4	28	A7	40	CAS0	52	DQ28	64	DQ34
5	DQ19	17	A5	29	NC	41	CAS2	53	DQ11	65	DQ16
6	DQ2	18	A6	30	VCC	42	CAS3	54	DQ29	66	NC
7	DQ20	19	A10	31	A8	43	CAS1	55	DQ12	67	PD1
8	DQ3	20	DQ4	32	A9	44	RAS0	56	DQ30	68	PD2
9	DQ21	21	DQ22	33	RAS3	45	RAS1	57	DQ13	69	PD3
10	VCC	22	DQ5	34	RAS2	46	NC	58	DQ31	70	PD4
11	NC	23	DQ23	35	NC	47	WE	59	VCC	71	NC
12	A0	24	DQ6	36	NC	48	NC	60	DQ32	72	VSS

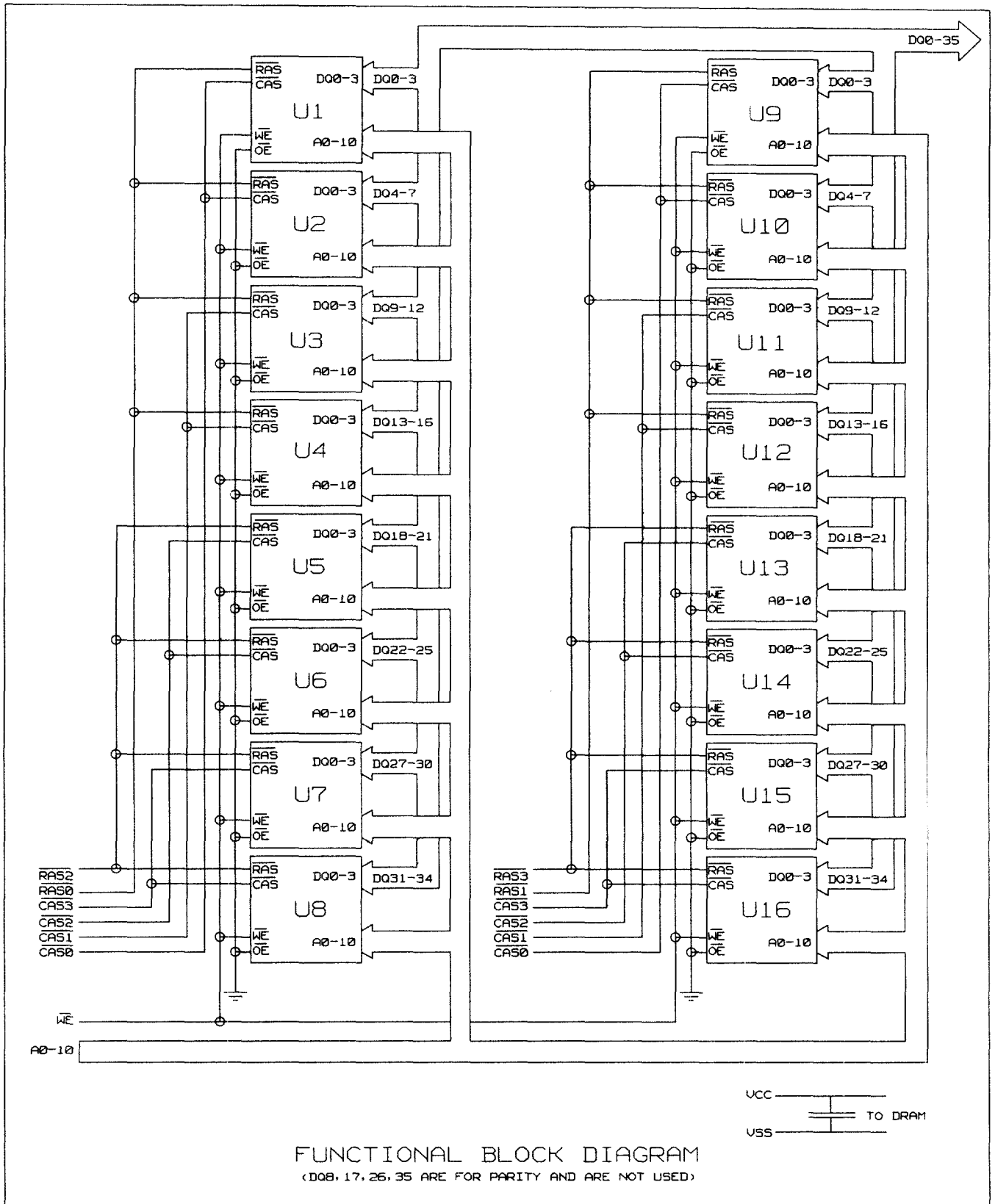

TRUTH TABLE

FUNCTION		RAS	CAS	WE	ROW ADDR	COL ADDR	DATA IN/OUT
Standby		H	H-X	X	X	X	Hi-Z
Read		L	L	H	ROW	COL	Valid D _{OUT}
Early-Write		L	L	L	ROW	COL	Valid D _{IN}
EDO Mode-Read	1st Cycle	L	H-L	H	ROW	COL	Valid D _{OUT}
	2nd Cycle	L	H-L	H	N/A	COL	Valid D _{OUT}
EDO Mode-Read (WE Control)	1st Cycle	L	H-L	L	ROW	COL	Valid D _{OUT}
	2nd Cycle	L	H-L	H-L-H	N/A	COL	Valid D _{OUT}
EDO Mode-Write	1st Cycle	L	H-L	L	ROW	COL	Valid D _{IN}
	2nd Cycle	L	H-L	L	N/A	COL	Valid D _{IN}
RAS-Only Refresh		L	H	X	ROW	N/A	Hi-Z
Hidden Refresh	Read	L-H-L	L	H	ROW	COL	Valid D _{OUT}
	Write	L-H-L	L	L	ROW	COL	Valid D _{IN}
CAS-Before-RAS Refresh		H-L	L	H	X	X	Hi-Z

X:"H" or "L" D_{IN}:Data In D_{OUT}:Data Out Hi-Z:High Impedance N/A:Not Applicable

ABSOLUTE MAXIMUM RATINGS (Note 1,22)

SYMBOL	PARAMETER	RATING	UNITS	NOTES
V _{CC}	Power Supply Voltage	-1.0 to 7.0	V	2
V _{IN}	Voltage on any Pin Relative to V _{SS}	-1.0 to 7.0	V	2
V _{OUT}		-1.0 to 7.0	V	2
T _{opr}	Operating Temperature	0 to 70	°C	
T _{stg}	Storage Temperature	-55 to 125	°C	
P _D	Power Dissipation	16.0	W	17,31
I _{os}	Short Circuit Output Current	50	mA	17

RECOMMENDED OPERATING CONDITIONS ($T_A = 0$ to 70 °C) (Note 2)

SYMBOL	PARAMETER	MIN.	TYP.	MAX.	UNITS	NOTES
V_{CC}	Supply Voltage	4.5	5.0	5.5	V	
V_{SS}	Ground	0	0	0	V	
V_{IH}	Input High Voltage	2.4	-	$V_{CC}+1.0$	V	22
V_{IL}	Input Low Voltage	-1.0	-	0.8	V	22

 T_A : Ambient temperature

CAPACITANCE ($f = 1$ MHz; $T_A = 25$ °C) (Note 22)

SYMBOL	PARAMETER	MAX.	UNITS	NOTES
C_{I1}	Input Capacitance (A0-A10)	80	pF	
C_{I2}	Input Capacitance (RAS0-RAS3)	28	pF	
C_{I3}	Input Capacitance (CAS0-CAS3)	28	pF	
C_{I4}	Input Capacitance (WE)	112	pF	
C_{O1}	Output Capacitance (Data In/Out)	14	pF	

 T_A : Ambient temperature

DC CHARACTERISTICS

(Recommended operating conditions unless otherwise noted.) (Note 18,22)

SYMBOL	PARAMETER	SPEED	MIN.	MAX.	NOTES	
I _{CC1}	OPERATING CURRENT: Average Power Supply Operating Current ($\overline{RAS}, \overline{CAS}$, Address Cycling @ $t_{RC} = t_{RC(min)}, V_{CC} = V_{CC(max)}$) (mA)	60 ns	-	896	3,4,5, 6,16	
		70 ns	-	816		
I _{CC2}	STANDBY CURRENT (TTL): Power Supply Standby Current ($\overline{RAS} = \overline{CAS} = V_{CC}$, Data out is disabled (Hi-Z), all other inputs = V_{CC} , $V_{CC} = V_{CC(max)}$) (mA)	Don't Care	-	32		
I _{CC3}	\overline{RAS} -ONLY REFRESH CURRENT: Average Power Supply Current, \overline{RAS} -Only Mode (\overline{RAS} , Address Cycling, $\overline{CAS} = V_{IH}$ @ $t_{RC} = t_{RC(min)}, V_{CC} = V_{CC(max)}$) (mA)	60 ns	-	1760	3,4,5,6,16, 31	
		70 ns	-	1600		
I _{CC4}	EXTENDED DATA OUT MODE CURRENT: Average Power Supply Current, EDO ($\overline{RAS} = V_{IL}, \overline{CAS}$, Address Cycling @ $t_{PC} = t_{PC(min)}, V_{CC} = V_{CC(max)}$) (mA)	60 ns	-	816	3,4,5,7,16	
		70 ns	-	736		
I _{CC5}	STANDBY CURRENT (CMOS): Power Supply Standby Current ($\overline{RAS} = \overline{CAS} = V_{CC} - 0.2V$, Data Out is disabled (Hi-Z), $V_{CC} = V_{CC(max)}$) (mA)	Don't Care	-	16		
I _{CC6}	\overline{CAS} -BEFORE- \overline{RAS} , REFRESH CURRENT: Average Power Supply Current, \overline{CAS} -Before- \overline{RAS} Mode ($\overline{RAS}, \overline{CAS}$ Cycling @ $t_{RC} = t_{RC(min)}, V_{CC} = V_{CC(max)}$) (mA)	60 ns	-	1760	3,4,5,6,16, 31	
		70 ns	-	1600		
I _{LI}	INPUT LEAKAGE CURRENT: Input Leakage Current, any input ($0 \leq V_{IN} \leq V_{CC}$, all other pins not under test = 0V, $V_{CC} = V_{CC(max)}$) (μA)	A0-A10, WE		-160	160	
		RAS0-RAS3		-40	40	
		CAS0-CAS3		-40	40	
I _{LO}	OUTPUT LEAKAGE CURRENT: (Data Out is disabled (Hi-Z), $0 \leq V_{OUT} \leq V_{CC}$) (μA)		-20	20		
V _{OH}	OUTPUT HIGH LEVEL: Output "H" Level Voltage ($I_{OUT} = -5mA$) (V)		2.4	-	2	
V _{OL}	OUTPUT LOW LEVEL: Output "L" Level Voltage ($I_{OUT} = +4.2mA$) (V)		-	0.4	2	

AC CHARACTERISTICS
READ, WRITE, AND REFRESH CYCLES (COMMON PARAMETERS)

(Recommended operating conditions unless otherwise noted.) (Note 8,18)

SYMBOL	PARAMETER	60 ns		70 ns		NOTES
		MIN.	MAX.	MIN.	MAX.	
t_{RC}	Random READ or WRITE Cycle Time (ns)	104	-	124	-	
t_{RP}	RAS Precharge Time (ns)	40	-	50	-	
t_{CP}	CAS Precharge Time (ns)	10	-	10	-	
t_{RAS}	RAS Pulse Width (ns)	60	10000	70	10000	23
t_{CAS}	CAS Pulse Width (ns)	10	10000	15	10000	23
t_{ASR}	Row Address Setup Time (ns)	0	-	0	-	22
t_{RAH}	Row Address Hold Time (ns)	10	-	10	-	
t_{ASC}	Column Address Setup Time (ns)	0	-	0	-	22
t_{CAH}	Column Address Hold Time (ns)	10	-	15	-	22
t_{RCD}	RAS to CAS Delay Time (ns)	20	45	20	50	10
t_{RAD}	RAS to Col. Address Delay Time (ns)	15	30	15	35	15,23
t_{RSH}	RAS Hold Time (ns)	15	-	20	-	22
t_{CSH}	CAS Hold Time (ns)	50	-	55	-	
t_{CRP}	CAS to RAS Precharge Time (ns)	5	-	5	-	22
t_{RPC}	RAS Precharge to CAS hold Time (ns)	5	-	5	-	22
t_T	Transition Time (Rise and Fall) (ns)	2	30	2	30	22
t_{AR}	Column Address Hold Time Referenced to RAS (ns)	-	-	-	-	

READ CYCLES (Note 8,18)

SYMBOL	PARAMETER	60 ns		70 ns		NOTES
		MIN.	MAX.	MIN.	MAX.	
t_{RAC}	Access Time from \overline{RAS} (ns)	-	60	-	70	9,10,15,30
t_{CAC}	Access Time from \overline{CAS} (ns)	-	15	-	20	9,10,30
t_{AA}	Access Time from Address (ns)	-	30	-	35	9,15,30
t_{RCS}	Read Command Setup Time (ns)	0	-	0	-	22
t_{RCH}	Read Command Hold Time to \overline{CAS} (ns)	0	-	0	-	14,22
t_{RRH}	Read Command Hold Time to \overline{RAS} (ns)	0	-	0	-	14,22
t_{RAL}	Column Address to \overline{RAS} Lead Time(ns)	30	-	35	-	22
t_{CLZ}	\overline{CAS} to Output in Low-Z (ns)	0	-	0	-	9,22
t_{DZC}	Data to \overline{CAS} Low Delay Time (ns)	-	-	-	-	

WRITE CYCLES (Note 8,18)

SYMBOL	PARAMETER	60 ns		70 ns		NOTES
		MIN.	MAX.	MIN.	MAX.	
t_{WCS}	Write Command Set Up Time (ns)	0	-	0	-	13
t_{WCH}	Write Command Hold Time (ns)	10	-	15	-	
t_{WP}	Write Command Pulse Width (ns)	10	-	15	-	22
t_{RWL}	Write Command to \overline{RAS} Lead Time (ns)	15	-	20	-	22
t_{CWL}	Write Command to \overline{CAS} Lead Time (ns)	10	-	15	-	22
t_{DS}	D_{IN} Setup Time (ns)	0	-	0	-	25
t_{DH}	D_{IN} Hold Time (ns)	10	-	15	-	22,25
t_{WCR}	Write Command Hold Time Referenced to \overline{RAS} (ns)	-	-	-	-	
t_{DHR}	Data in Hold Time Referenced to \overline{RAS} (ns)	-	-	-	-	

EXTENDED DATA OUT MODE CYCLES (Note 8,9,18)

SYMBOL	PARAMETER	60 ns		70 ns		NOTES
		MIN.	MAX.	MIN.	MAX.	
t_{HPC}	EDO Mode Cycle Time (ns)	25	-	30	-	22
t_{RASP}	EDO Mode RAS Pulse Width (ns)	60	100000	70	100000	
t_{HCAS}	EDO MODE CAS Pulse Width (ns)	10	10000	15	10000	22
t_{CPRH}	RAS Hold Time from CAS Precharge (ns)	35	-	40	-	22
t_{CPA}	Access Time from CAS Precharge (ns)	-	35	-	40	21,22,30
t_{WPZ}	EDO Mode Write Command Pulse Width (ns)	-	-	-	-	
t_{DOH}	D _{OUT} Hold Time (ns)	3	-	3	-	22
t_{WHZ}	Output Buffer Turn-Off Delay from WE (ns)	3	-	3	-	12,22
t_{CPW}	WE Delay Time From CAS Precharge (ns)	54	-	64	-	

REFRESH CYCLE (Note 8,18)

SYMBOL	PARAMETER	60 ns		70 ns		NOTES
		MIN.	MAX.	MIN.	MAX.	
t_{CHR}	CAS Hold Time (CAS-before-RAS Refresh Cycle) (ns)	15	-	15	-	22
t_{CSR}	CAS Setup Time (CAS-before-RAS Refresh Cycle) (ns)	5	-	5	-	
t_{WRP}	WE Setup Time (CAS-before-RAS Refresh Cycle) (ns)	10	-	10	-	22
t_{WRH}	WE Hold Time (CAS-before-RAS Refresh Cycle) (ns)	10	-	10	-	22
t_{REF}	Refresh Period (2048 cycles) (ms)	-	32	-	32	

NOTES

1. Permanent damage to the device may occur if "ABSOLUTE MAXIMUM RATINGS" are exceeded. Functional operation should be restricted to the conditions as detailed in this data sheet. Exposure to absolute maximum rating conditions for extended periods may affect reliability.
2. All voltages referenced to V_{SS} .
3. I_{CC} is specified as an average current.
4. This parameter depends on output loading and/or cycle rates.
5. Specified values are obtained with the output open.
6. Address can be changed a maximum of once while $\overline{RAS}=V_{IL}$.
7. Address can be changed a maximum of once while $\overline{CAS}=V_{IH}$.
8. $V_{IH(min)}$ and $V_{IL(max)}$ are reference levels for measuring timing of input signals. Transition time (t_T) is measured between $V_{IH(min)}$ and $V_{IL(max)}$, and is assumed to be 2ns for all inputs. All input signals must transit between V_{IH} and V_{IL} (or V_{IL} and V_{IH}) without slope reversal.
9. Measured with a load equivalent to 2 TTL loads and 100pF.
10. Operation within the $t_{RCD(max)}$ limit ensures that $t_{RAC(max)}$ can be met. $t_{RCD(max)}$ is specified as a reference point only. If t_{RCD} is greater than the specified $t_{RCD(max)}$ limit, then access time is controlled exclusively by t_{CAC} .
11. Assumes that $t_{RCD} \geq t_{RCD(max)}$, $t_{RAD} \leq t_{RAD(max)}$.
12. This parameter defines the time at which the output achieves the open circuit condition and is not referenced to V_{OH} or V_{OL} .
13. This is a non-restrictive operating parameter. It is included in the data sheet as an electrical characteristic only. If $t_{WCS} \geq t_{WCS(min)}$ the cycle is an early write cycle and the data out pins will remain high impedance (open circuit) for the duration of the cycle. If the above condition is not satisfied, the condition of the data out (at access time) is indeterminate.
14. Either t_{RCH} or t_{RRH} must be satisfied for a read cycle.
15. Operation within the $t_{RAD(max)}$ limit ensures that $t_{RAC(max)}$ can be met. $t_{RAD(max)}$ is specified as a reference point only. If t_{RAD} is greater than the specified $t_{RAD(max)}$ limit, then access time is controlled exclusively by t_{AA} .
16. Specified values are obtained with minimum cycle time.
17. Specified values are obtained with $T_A = 25^\circ C$.

18. An initial pause of 200 μ s is required after power-up followed by a minimum of eight initialization cycles (any 8 $\overline{\text{CAS}}$ -before- $\overline{\text{RAS}}$ or $\overline{\text{RAS}}$ -only Refresh cycles with $\overline{\text{WE}}$ high) before proper device operation is assured. Also, any 8 $\overline{\text{CAS}}$ -before- $\overline{\text{RAS}}$ or $\overline{\text{RAS}}$ -only Refresh cycles with $\overline{\text{WE}}$ high are required after prolonged periods (greater than t_{REF}) of $\overline{\text{RAS}}$ inactivity before proper device operation is assured.
19. Measured with a load equivalent to 50pF and 500 ohms.
20. Write cycle is applicable instead of read cycle. Timing requirements for $\overline{\text{RAS}}$, $\overline{\text{CAS}}$ and Address are the same for Hidden Refresh Write Cycle as that shown for Hidden Refresh Read Cycle. $\overline{\text{WE}}$, D_{IN} and D_{OUT} for Hidden Refresh Write Cycle are the same as for Write Cycle.
21. t_{CPA} is access time from $\overline{\text{CAS}}$ precharge (that is caused by changing $\overline{\text{CAS}}$ from "L" to "H"). Therefore, if t_{CP} is long, then t_{CPA} is longer than $t_{\text{CPA}(\text{max})}$.
22. Calculated based on data supplied by the DRAM manufacturer(s).
23. Maximum value is calculated based on data supplied by the DRAM manufacturer(s).
24. Minimum value is calculated based on data supplied by the DRAM manufacturer(s).
25. This parameter is referenced to the $\overline{\text{CAS}}$ leading edge in Early Write cycles and to the $\overline{\text{WE}}$ leading edge in Read-Modify-Write cycles.
26. $V_{\text{IN}} = 0$ Volt.
27. Either t_{CDD} or t_{ODD} must be satisfied.
28. Either t_{DZC} or t_{DZO} must be satisfied.
29. $t_{\text{RASP}(\text{MIN})}$ is specified as two cycles of $\overline{\text{CAS}}$ input are performed.
30. The access time is limited by all four parameters t_{RAC} , t_{CAC} , t_{AA} , t_{CPA} .
31. This assumes all $\overline{\text{RAS}}$ (and all $\overline{\text{CAS}}$ for CBR refresh) are active.

For Timing Diagrams see “**EDO Timing Diagrams**” (Document No. **20431C**).

Available from fax-on-demand and Website: <http://www.celestica.com/memory/>

Celestica Inc. 1996
Contact Information
For further information on this product, please call:

Celestica 1-888-899-9998

The information provided is believed to be accurate and reliable. Celestica reserves the right to make changes to this document and to the product described without notice. No liability is assumed as a result of its use nor for any infringement on the rights of others.

TM Celestica is a trademark of Celestica, Inc.

August 13, 1996