

1612A/B 1310 nm DFB Laser Module

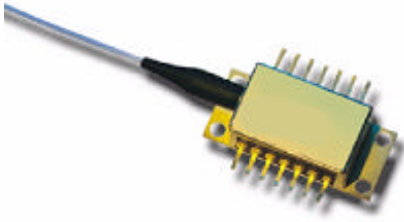

The 1612A/B 1310 nm forward path DFB laser modules are designed for both broadcast and narrowcast analog applications. The highly linear, OC-48 pinout compatible devices feature options up to 31 mW of minimum optical output power with superior distortion performance over an enhanced temperature range of -40°C to +85°C.

Applications

- 1310 nm forward path/return path
- Broadcast and narrowcast networks
- Long distances
- High optical splits

Features

- OC-48 pinout compatible
- *Telcordia Technologies*[™] 468 compliant
- Up to 110 channel count
- Up to 31 mW
- Wide temperature range—stable even in harsh environments

Performance Highlights

	Min	Typical	Max	Units
Wavelength	1300	-	1320	nm
Optical Output Power (multiple versions)	4-31	-	-	mW
Temperature Range	-40	-	+85	°C
Frequency Range	5	-	860	MHz
Carrier to Noise Ratio	51	-	-	dB
Composite Second Order (multiple versions)	55-60	-	-	dB
Composite Triple Beat (multiple versions)	65-68	-	-	dB

See following pages for complete specifications and conditions.

Absolute Maximum Ratings

Stresses in excess of the absolute maximum ratings can cause permanent damage to the device. These are absolute stress ratings only. Functional operation of the device is not implied at these or any other conditions in excess of those given in the operational sections of the data sheet. Exposure to absolute maximum ratings for extended periods can adversely affect device reliability.

Parameter	Symbol	Condition	Min	Max	Units
Operating Case Temperature	T_C	continuous	-40	+85	°C
Storage Temperature	T_{STG}	-	-40	+85	°C
Laser Forward dc Current	-	-	-	150	mA
Photodiode Reverse Voltage	V_{RPD}	-	-	10	V
Laser Reverse Voltage, dc	-	-	-	1	V
ESD	-	HBM: R = 1500 Ohm, C = 100 pF	-500	500	V
TEC Current	I_{TEC}	continuous	-1.9	1.9	A

Electrical/Optical Characteristics

Laser Temperature (T_L) = 25°C, $I_F = I_{OP}$, Beginning of Life (BOL)

Parameter	Symbol	Condition	Min	Typ	Max	Unit
Wavelength	-	-	1300	-	1320	nm
Optical Output Power	-	1612-xxxx-04 version See ordering page for options 1612-xxxx-31 version	4 . 31	-	-	mW mW
Optical Isolation	ISO	-	30	-	-	dB
Sidemode Suppression Ratio	SMSR	-	35	-	-	dB
Threshold Current	I_{TH}	-	-	-	20	mA
Operating Current	I_{OP}	varies with power option	-	-	120	mA
Monitor PD Responsivity	r_{PD}	$V_{RM}=5V$	10	-	200	$\mu A/mW$
Thermistor Resistance	R_{TH}	$T_{OP}=25^\circ C$	9.5	10	10.5	KOhm
Thermistor Temp. Coefficient	TC_{TH}	$T_{OP}=25^\circ C$	-	-4.4	-	%/°C
TEC Current	I_{TEC}	$-40 < T_C < +85^\circ C$, $I_F = 100$ mA	-1.5	-	1.6	A
Fiber Length	-	May include splice	1.0	1.5	-	m
Fiber Buffer	-	-	-	900	-	μm
Fiber Core / Cladding	-	-	-	9/125	-	μm

RF Characteristics

Laser Temperature (T_L) = 25°C, $I_F = I_{OP}$, Beginning of Life (BOL)

Parameter	Symbol	Condition	Min	Typ	Max	Unit
Frequency Range	F	-	5	-	860	MHz
Frequency Response	S21	$I_F = 60$ mA, 5 MHz-860 MHz	-	-	± 0.5	dB
Carrier-to-Noise Ratio	CNR	-	51	-	-	dB
Comp. Second Order, A-option	CSO	4, 6, 8 mW options ≥ 10 mW options	55 57	-	-	dB dB
Comp. Second Order, B-option	CSO	-	60	-	-	dB
Composite Triple Beat	CTB	varies with power option	65-68	-	-	dB
Relative Intensity Noise	RIN	-	-	<-155	-	dB/Hz

3.2% OMI, 112 ch. NTSC

In order to prevent reflection-induced distortion, the laser must be connected to an optical cable having a return loss of at least 55 dB for discrete reflections and 30 dB for distributed reflections.

Electrical Schematics

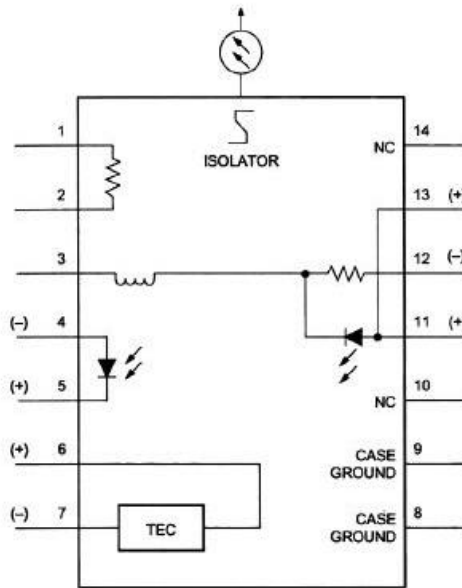

Figure 1. 1612A/B Laser Schematic

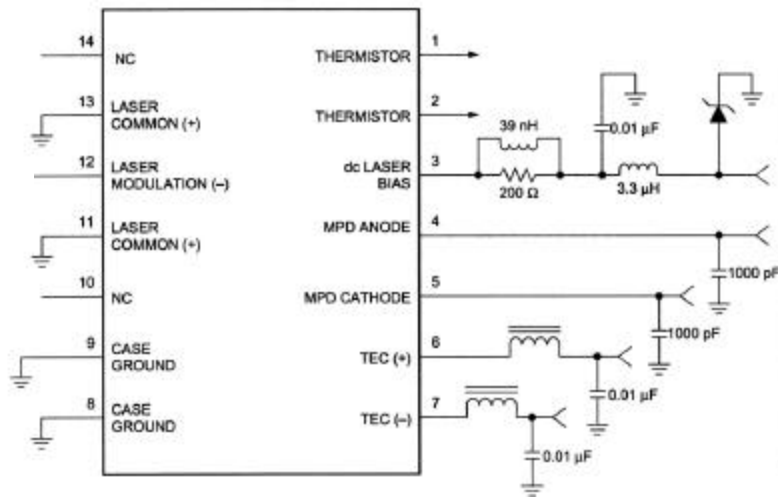
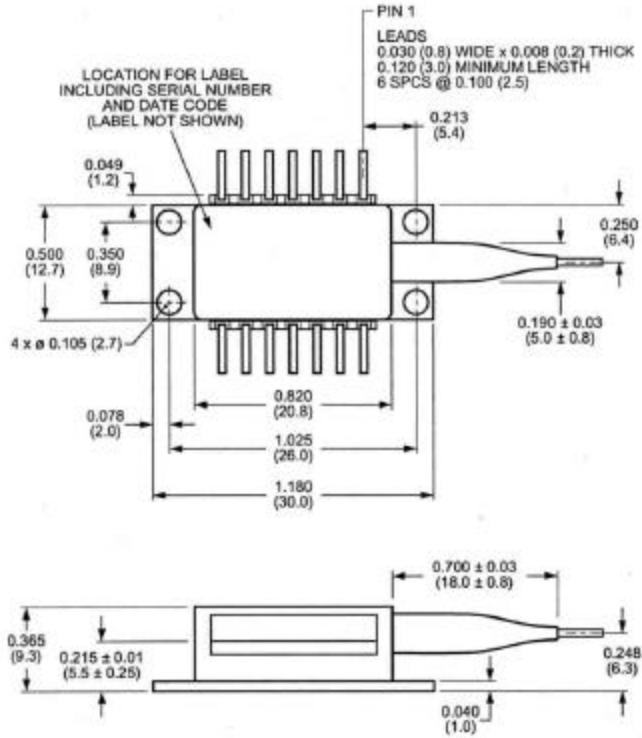

Figure 2. 1612A/B Circuit Schematic

Outline Diagram

Dimensions are in inches and (millimeters)



Pin Information

Pin No.	Description
1	Thermistor
2	Thermistor
3	Dc Laser Bias (-)
4	MPD Anode (-)
5	MPD Cathode (+)
6	Thermal Electric Cooler (+)
7	Thermal Electric Cooler (-)
8	Case Ground
9	Case Ground
10	NC
11	Laser Common (+)
12	Laser Modulation (-)
13	Laser Common (+)
14	NC

Laser Safety

This product meets the appropriate standard in Title 21 of the Code of Federal Regulations (CFR). FDA/CDRH Class IIIb laser product. This device has been classified with the FDA/CDRH under accession number 0220191.

Single-mode fiber pigtail with SC/APC connectors (standard).

Wavelength = 1.3 μm .

Maximum power = 50 mW.

Because of size constraints, laser safety labeling (including an FDA class IIIb label) is not affixed to the module, but attached to the outside of the shipping carton.

Product is not shipped with power supply.

Caution: Use of controls, adjustments and procedures other than those specified herein may result in hazardous laser radiation exposure.

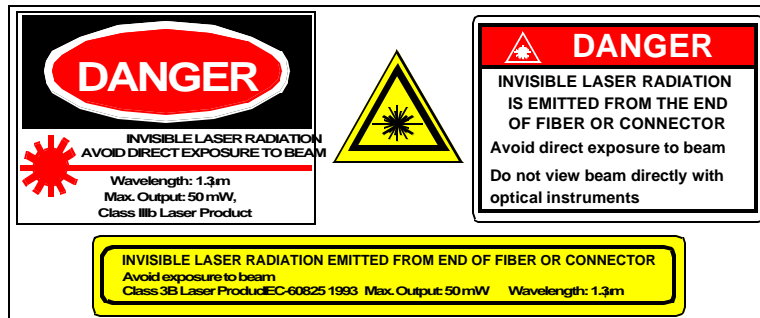

Ordering Information

Contact Ortel for ordering information at 626-293-3400.

Ordering Code Definitions

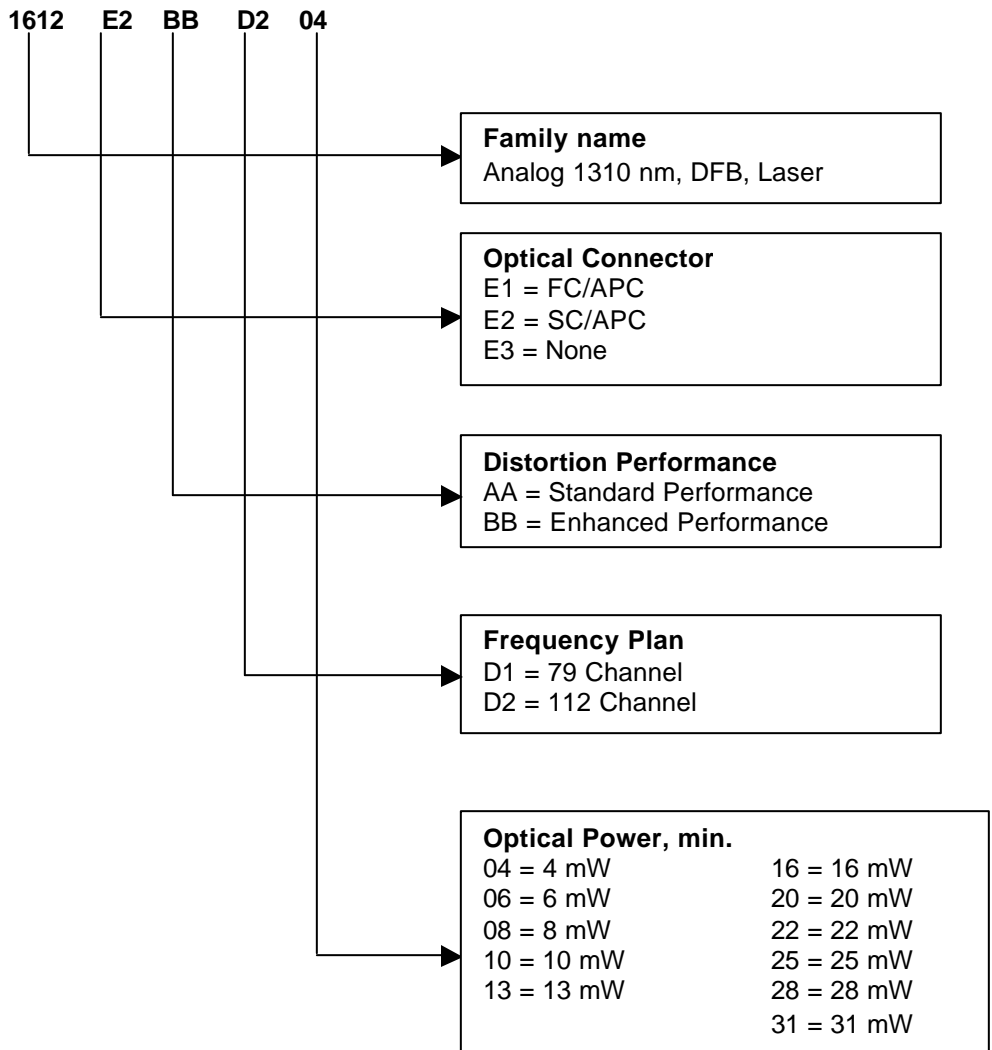

Information contained herein is deemed to be reliable and accurate as of issue date. EMCORE reserves the right to change the design or specifications of the product at any time without notice. Ortel, the Ortel logo, EMCORE, and the EMCORE logo are trademarks of EMCORE Corporation.



Ortel, a division of EMCORE

2015 West Chestnut Street
Alhambra, California 91803-1542
Tel: 626-293-3400
Fax: 626-293-3428
www.emcore.com

