

Surface Mount RF PIN Diodes in SOT-363 (SC-70, 6 Lead)

Technical Data

HSMP-389L/T/U

Features

- **Diodes Optimized for:**
Ultra-Low Distortion Switching
Microwave Frequency
Operation
- **Surface Mount SOT-363
(SC-70)Package**
Single, Pair, and Trio Versions
Tape and Reel Options
Available
- **Low Failure in Time (FIT)
Rate***

* For more information see the
Surface Mount PIN Reliability
Data Sheet.

Package Lead Code Identification (Top View)

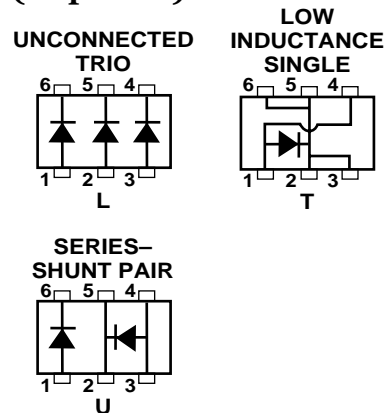

Description/Applications

The HSMP-389L/T/U is optimized for switching applications where low resistance at low current, and low capacitance are required.

Pin Connections and Package Marking

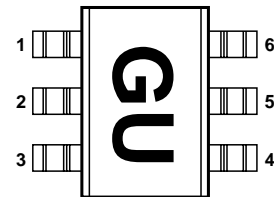

Notes:

1. Package marking provides orientation and identification.
2. See "Electrical Specifications" for appropriate package marking.

Absolute Maximum Ratings^[1], $T_C = + 25^\circ\text{C}$

Symbol	Parameter	Unit	Absolute Maximum
I_f	Forward Current (1 μs Pulse)	Amp	1
P_{IV}	Peak Inverse Voltage	V	Same as V_{BR}
T_J	Junction Temperature	$^\circ\text{C}$	150
T_{STG}	Storage Temperature	$^\circ\text{C}$	-65 to 150
θ_{jc}	Thermal Resistance ^[2]	$^\circ\text{C}/\text{W}$	140

Notes:

1. Operation in excess of any one of these conditions may result in permanent damage to the device.
2. $T_C = 25^\circ\text{C}$, where T_C is defined to be the temperature at the package pins where contact is made to the circuit board.

Electrical Specifications, $T_C = +25^\circ\text{C}$, each diode

PIN Switching Diodes

Part Number HSMP-	Package Marking Code ^[1]	Lead Code	Configuration	Minimum Breakdown Voltage V_{BR} (V)	Maximum Total Resistance R_T (Ω)	Maximum Total Capacitance C_T (pF)
389L 389T 389U	GL GT GU	L T U	Unconnected Trio Low Inductance Single Series-Shunt Pair	100	2.5	0.30
Test Conditions				$V_R = V_{BR}$ Measure $I_R \leq 10 \mu\text{A}$	$I_F = 5 \text{ mA}$ $f = 100 \text{ MHz}$	$V_R = 5 \text{ V}$ $f = 1 \text{ MHz}$

Typical Parameters at $T_C = +25^\circ\text{C}$

Part Number HSMP-	Total Resistance R_T (Ω)	Carrier Lifetime τ (ns)	Reverse Recovery Time T_{rr} (ns)	Total Capacitance (pF)
389A Series	3.8	200	—	—
Test Conditions	$I_F = 1 \text{ mA}$ $f = 100 \text{ MHz}$	$I_F = 10 \text{ mA}$ $I_R = 6 \text{ mA}$	$V_R = 10 \text{ V}$ $I_F = 20 \text{ mA}$ 90% Recovery	50 V

Note:

1. Package marking code is laser marked.

HSMP-389A Series Typical Performance, $T_C = 25^\circ\text{C}$, each diode

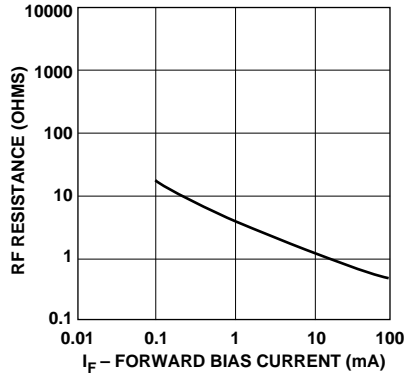

Figure 1. Total RF Resistance at 25°C vs. Forward Bias Current.

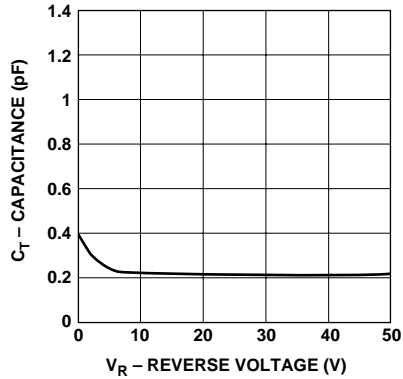

Figure 2. Capacitance vs. Reverse Voltage at 1 MHz.

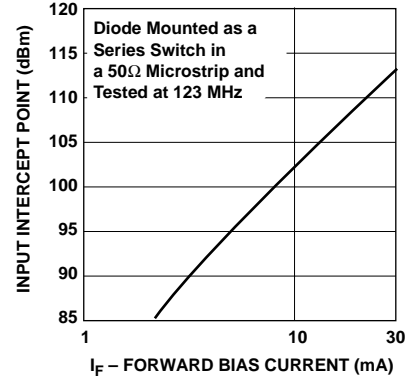

Figure 3. 2nd Harmonic Input Intercept Point vs. Forward Bias Current.

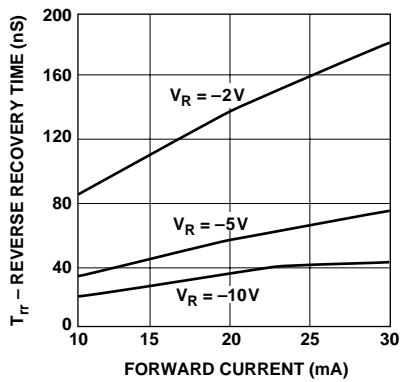

Figure 4. Typical Reverse Recovery Time vs. Reverse Voltage.

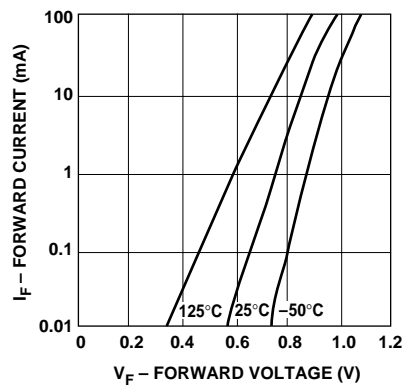

Figure 5. Forward Current vs. Forward Voltage.

Typical Applications for Multiple Diode Products

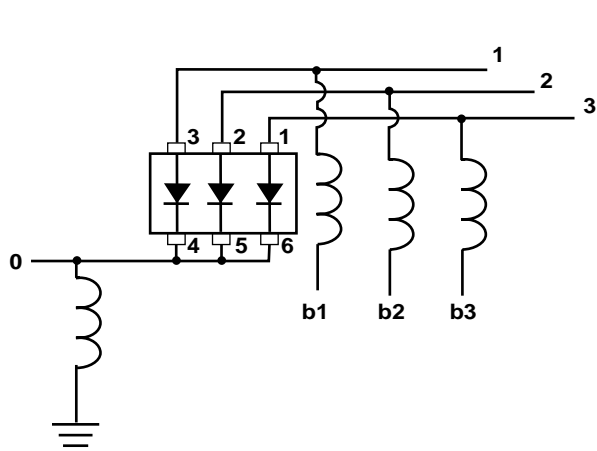

Figure 6. HSMP-389L used in a SP3T Switch.

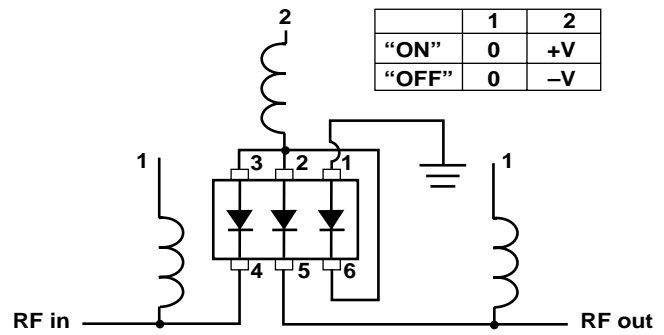

Figure 7. HSMP-389L Unconnected Trio used in a Dual Voltage, High Isolation Switch.

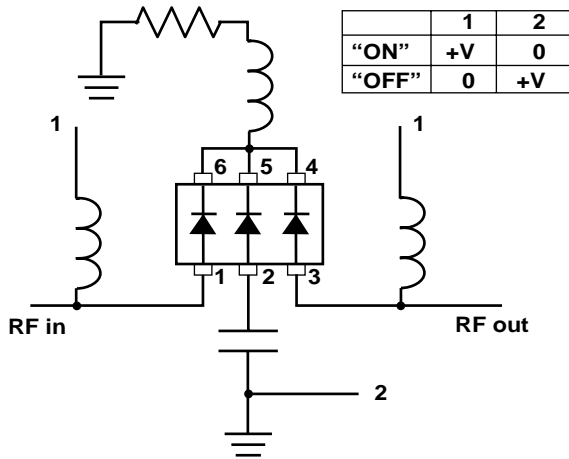

Figure 8. HSMP-389L Unconnected Trio used in a Positive Voltage, High Isolation Switch.

Typical Applications for Multiple Diode Products (continued)

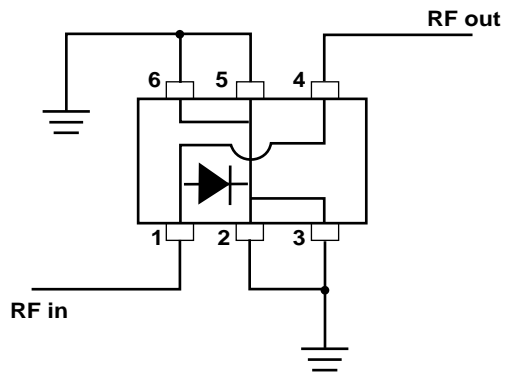

Figure 9. HSMP-389T used in a Low Inductance Shunt Mounted Switch.

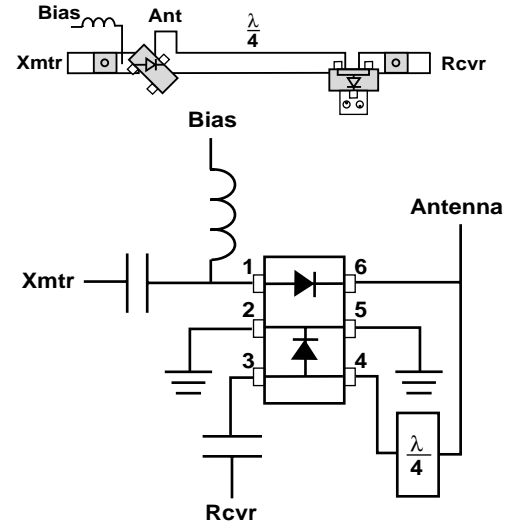

Figure 10. HSMP-389U Series/Shunt Pair used in a Transmit/Receive Switch.

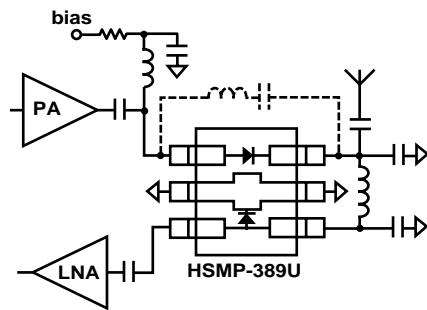

Figure 11. Tx/Rx Switch Configuration.

Assembly Information

SOT-363 PCB Footprint

A recommended PCB pad layout for the miniature SOT-363 (SC-70, 6 lead) package is shown in Figure 12 (dimensions are in inches). This layout provides ample allowance for package placement by automated assembly equipment without adding parasitics that could impair performance.

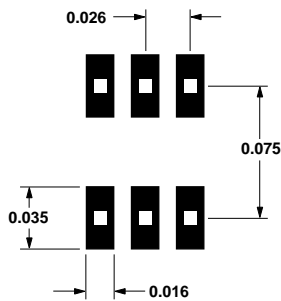

Figure 12. PCB Pad Layout (dimensions in inches).

SMT Assembly

Reliable assembly of surface mount components is a complex process that involves many material, process, and equipment factors, including: method of heating (e.g., IR or vapor phase reflow, wave soldering, etc.) circuit board material, conductor thickness and pattern, type of solder alloy, and the thermal conductivity and thermal mass of components. Components with a low mass, such as the SOT-363 package, will reach solder reflow temperatures faster than those with a greater mass.

HP's SOT-363 diodes have been qualified to the time-temperature profile shown in Figure 13. This profile is representative of an IR reflow type of surface mount assembly process.

After ramping up from room temperature, the circuit board with components attached to it (held in place with solder paste)

passes through one or more preheat zones. The preheat zones increase the temperature of the board and components to prevent thermal shock and begin evaporating solvents from the solder paste. The reflow zone briefly elevates the temperature sufficiently to produce a reflow of the solder.

The rates of change of temperature for the ramp-up and cool-down zones are chosen to be low enough to not cause deformation of the board or damage to components due to thermal shock. The maximum temperature in the reflow zone (T_{MAX}) should not exceed 235 °C.

These parameters are typical for a surface mount assembly process for HP SOT-363 diodes. As a general guideline, the circuit board and components should be exposed only to the minimum temperatures and times necessary to achieve a uniform reflow of solder.

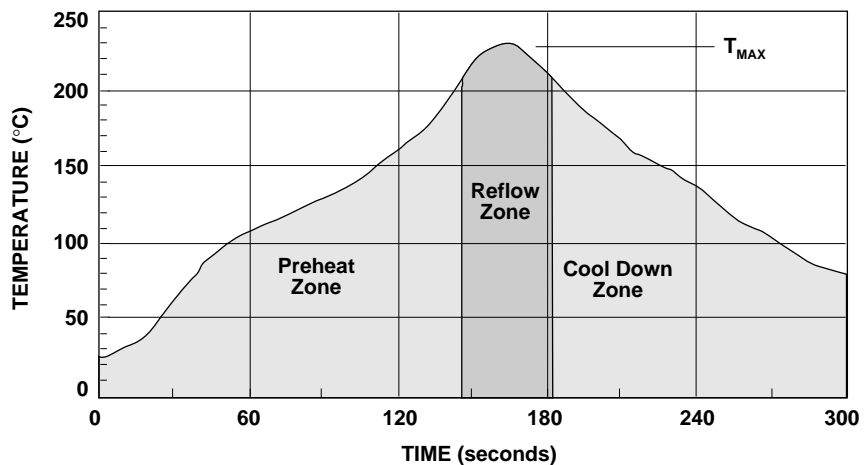
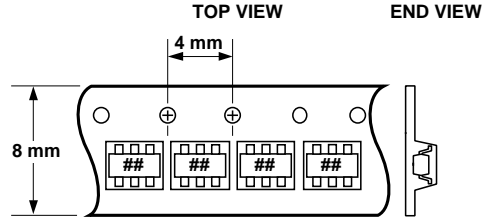
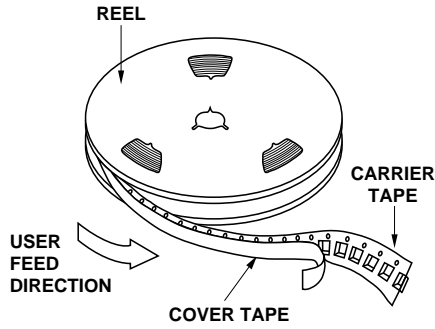

Figure 13. Surface Mount Assembly Profile.

Device Orientation



Note: "##" represents Package Marking Code. Package marking is right side up with carrier tape perforations at top. Conforms to Electronic Industries RS-481, "Taping of Surface Mounted Components for Automated Placement." Standard Quantity is 3,000 Devices per Reel.

Tape Dimensions For Outline SOT-363 (SC-70, 6 Lead)

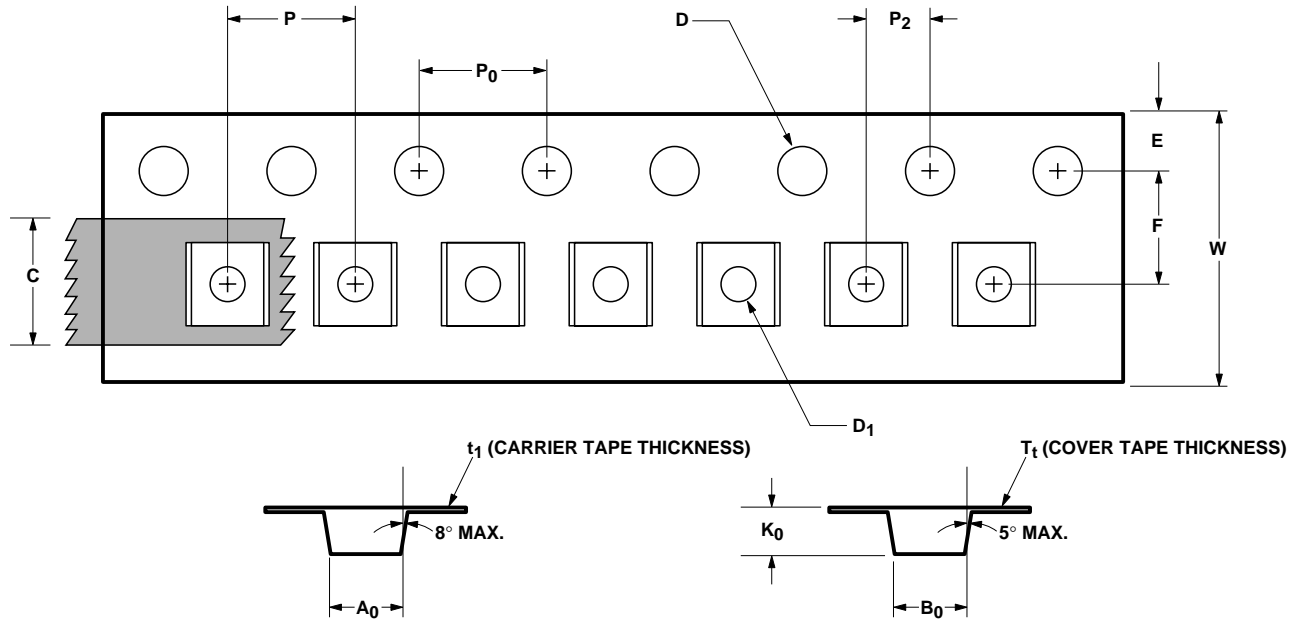

DESCRIPTION		SYMBOL	SIZE (mm)	SIZE (INCHES)
CAVITY	LENGTH	A ₀	2.24 ± 0.10	0.088 ± 0.004
	WIDTH	B ₀	2.34 ± 0.10	0.092 ± 0.004
	DEPTH	K ₀	1.22 ± 0.10	0.048 ± 0.004
	PITCH	P	4.00 ± 0.10	0.157 ± 0.004
	BOTTOM HOLE DIAMETER	D ₁	1.00 + 0.25	0.039 + 0.010
PERFORATION	DIAMETER	D	1.55 ± 0.05	0.061 ± 0.002
	PITCH	P ₀	4.00 ± 0.10	0.157 ± 0.004
	POSITION	E	1.75 ± 0.10	0.069 ± 0.004
CARRIER TAPE	WIDTH	W	8.00 ± 0.30	0.315 ± 0.012
	THICKNESS	t ₁	0.255 ± 0.013	0.010 ± 0.0005
COVER TAPE	WIDTH	C	5.4 ± 0.10	0.205 ± 0.004
	TAPE THICKNESS	T _t	0.062 ± 0.001	0.0025 ± 0.00004
DISTANCE	CAVITY TO PERFORATION (WIDTH DIRECTION)	F	3.50 ± 0.05	0.138 ± 0.002
	CAVITY TO PERFORATION (LENGTH DIRECTION)	P ₂	2.00 ± 0.05	0.079 ± 0.002

Package Dimensions

Outline SOT-363 (SC-70, 6 Lead)

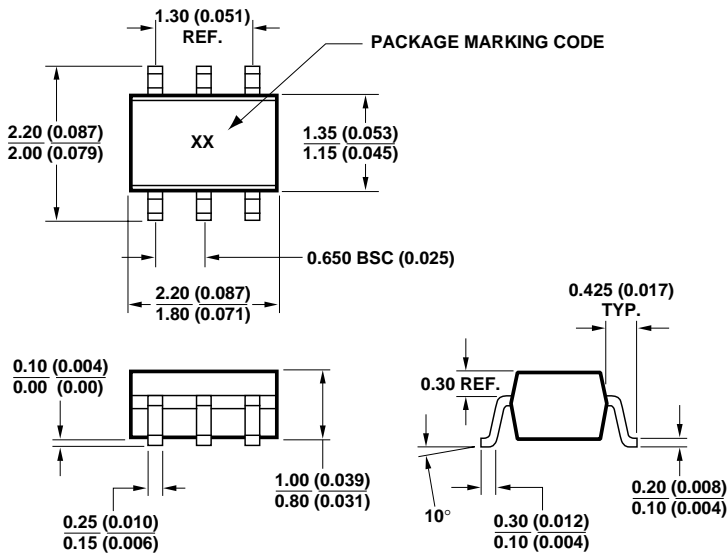

DIMENSIONS ARE IN MILLIMETERS (INCHES)

Package Characteristics

Lead Material Copper
 Lead Finish..... Tin-Lead 85/15%
 Maximum Soldering Temperature 260°C for 5 seconds
 Minimum Lead Strength 2 pounds pull
 Typical Package Inductance 2 nH
 Typical Package Capacitance 0.08 pF (opposite leads)

Part Number Ordering Information

Part Number	No. of Devices	Container
HSMP-389A-TR1*	3000	7" Reel
HSMP-389A-BLK*	100	antistatic bag

* where A = L, T or U

For technical assistance or the location of your nearest Hewlett-Packard sales office, distributor or representative call:

Americas/Canada: 1-800-235-0312 or 408-654-8675

Far East/Australasia: Call your local HP sales office.

Japan: (81 3) 3335-8152

Europe: Call your local HP sales office.

Data subject to change.
 Copyright © 1997 Hewlett-Packard Co.

Printed in U.S.A. 5966-2028E (10/97)