

DO NOT SCALE FROM THIS PRINT

ZF1-XX-XX-XX-WT-XX **D**

No OF POSITIONS  
-04 THRU -30

OPTIONS  
-TR: TAPE AND REEL

LEAD STYLE

-01: CONTACT BOTTOM  
-02: CONTACT TOP  
-03: TOP ENTRY (SEE SHEET 3)

WELD TAB

PLATING SPECIFICATION  
-T: TIN (.000120 MIN TIN OVER  
.000040 MIN NICKEL)  
(TIN/LEAD RATIO IS 9/1)  
**D**-TM: PURE TIN, MATTE FINISH

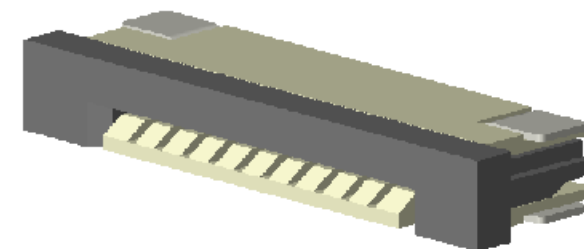
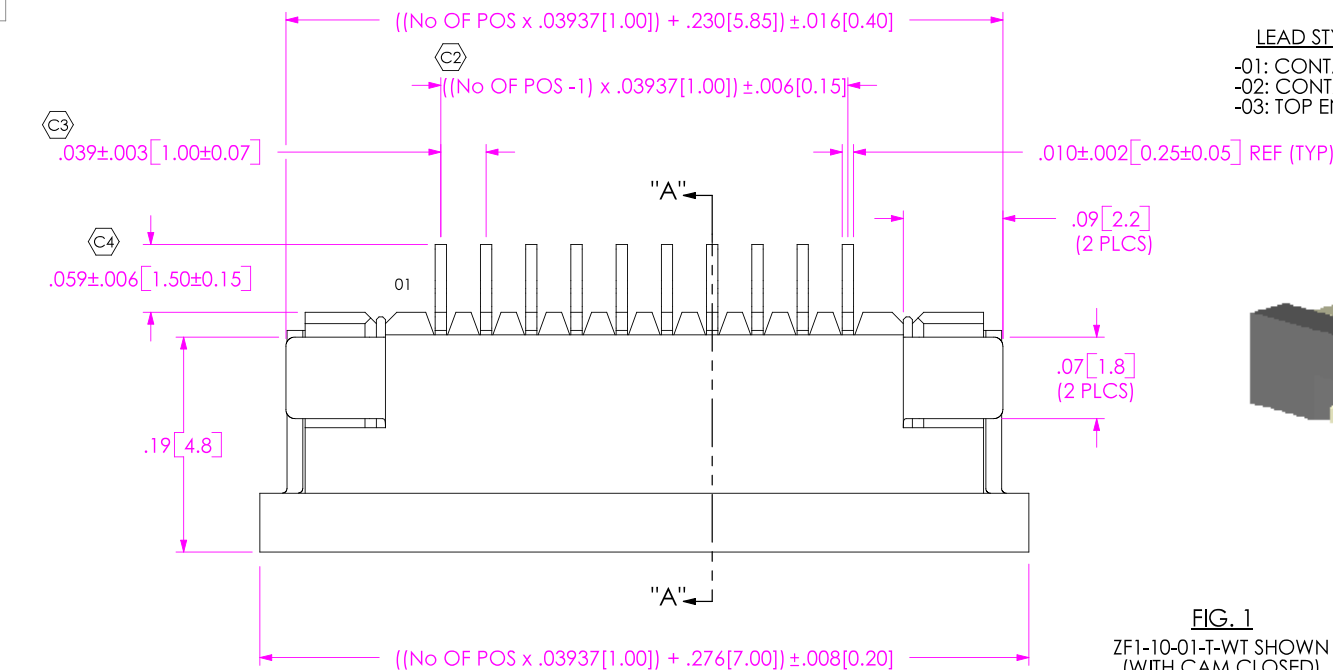
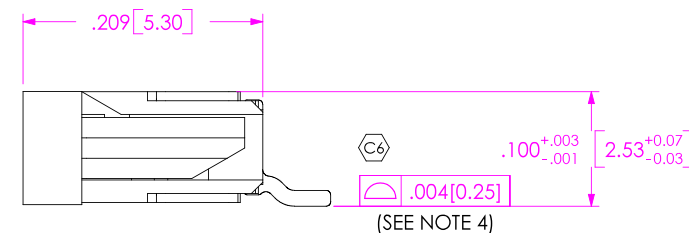
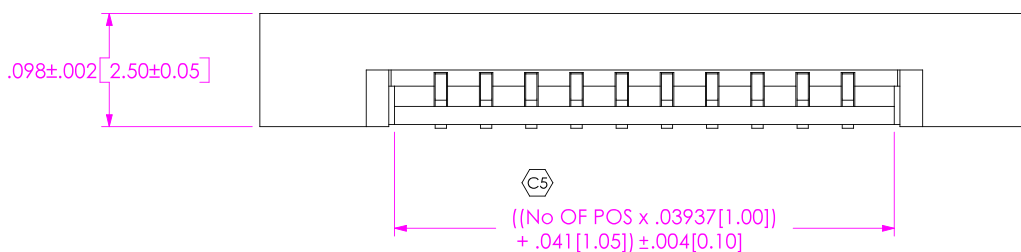

FIG. 1  
ZF1-10-01-T-WT SHOWN  
(WITH CAM CLOSED)



NOTES:

1. © REPRESENTS A CRITICAL DIMENSION.
2. BURR ALLOWANCE: .0010[0.25] MAXIMUM.
3. CONTACT; MINIMUM PUSHOUT FORCE: 6 OZ.
4. COPLANARITY INCLUDES TAILS AND WELD TABS.
5. WELD TAB RETENTION: 12 OZ.
6. BREAKOFF BURR NOT TO EXCEED .007[0.18] & MUST REMAIN ATTACHED.

UNLESS OTHERWISE SPECIFIED, DIMENSIONS ARE IN INCHES.  
TOLERANCES ARE:  
DECIMALS ANGLES  
.XX: ±.014[0.35]  
.XXX: ±.008[0.20]  
.XXXX: ±.0005[0.125]

PROPRIETARY NOTE

THIS DOCUMENT CONTAINS INFORMATION CONFIDENTIAL AND PROPRIETARY TO SAMTEC, INC. AND SHALL NOT BE REPRODUCED OR TRANSFERRED TO OTHER DOCUMENTS OR DISCLOSED TO OTHERS OR USED FOR ANY PURPOSE OTHER THAN THAT WHICH IT WAS OBTAINED WITHOUT THE EXPRESSED WRITTEN CONSENT OF SAMTEC, INC.

MATERIAL: DO NOT SCALE DRAWING  
HOUSING: LCP, COLOR: NATURAL  
CAM SLIDER: PPS, COLOR: BLACK  
CONTACT & WELD TAB:  
PHOS BRONZE  
MAX FLASH ALLOWED: .002  
MAX GATE VESTIGE: .002  
F:\DWG\MISC\MKTG\ZF1-XX-XX-XX-WT-XX-MKT.SLDDRW



SHEET SCALE: 6:1

**SAMTEC**

520 PARK EAST BLVD, NEW ALBANY, IN 47150  
PHONE: 812.944.6733 FAX: 812.948.5047  
e-Mail: [INFO@SAMTEC.COM](mailto:INFO@SAMTEC.COM) CODE: 55322

DESCRIPTION:  
ZERO INSERTION FORCE 1mm ASSEMBLY

DWG. NO. ZF1-XX-XX-XX-WT-XX

BY: KEVIN B 9/20/2002 SHEET 1 OF 3

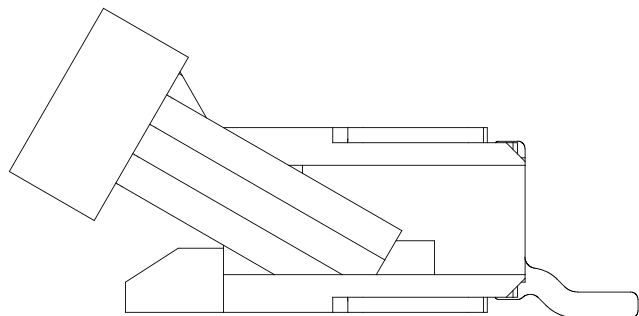

-01 LEAD STYLE [CONTACT BOTTOM]  
(WITH CAM OPEN)

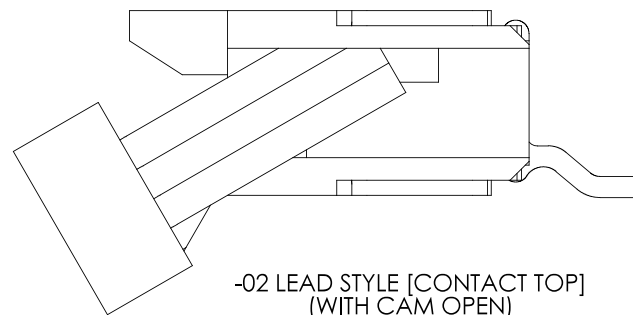

-02 LEAD STYLE [CONTACT TOP]  
(WITH CAM OPEN)

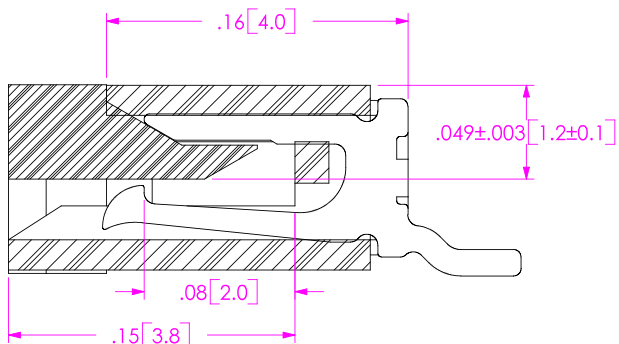

**SECTION "A"-"A"**  
-01 LEAD STYLE  
(WITH CAM CLOSED)

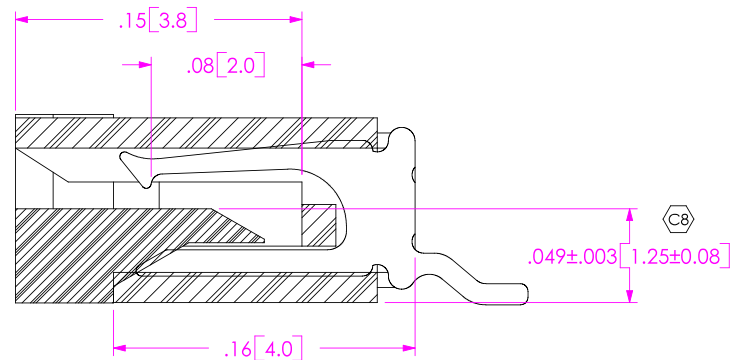

**SECTION "A"-"A"**  
-02 LEAD STYLE  
(WITH CAM CLOSED)

**PACKAGING VIEWS**

[PARTS TO HAVE POSITION #1 LOADED IN  
SAME DIRECTION AS ARROW ON TUBE]

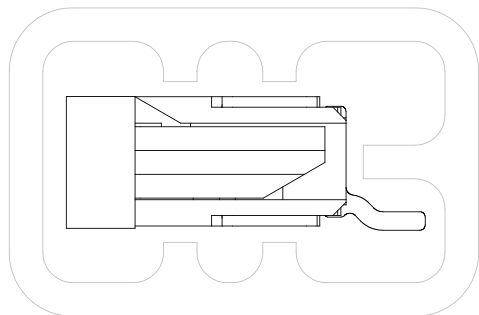

-01 & -02 LEAD STYLE:  
TUBE: PT-1-24-02-117  
PLUG: TP-24

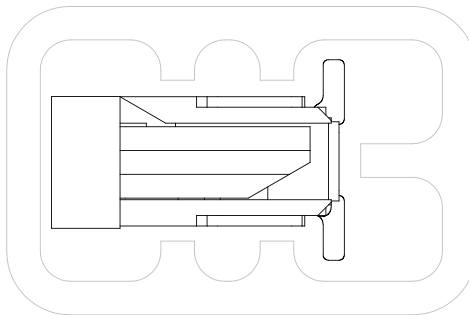

-03 LEAD STYLE:  
TUBE: PT-1-24-02-117  
PLUG: TP-24

**PROPRIETARY NOTE**

THIS DOCUMENT CONTAINS INFORMATION  
CONFIDENTIAL AND PROPRIETARY TO  
SAMTEC, INC. AND SHALL NOT BE REPRODUCED  
OR TRANSFERRED TO OTHER DOCUMENTS OR  
DISCLOSED TO OTHERS OR USED FOR ANY  
PURPOSE OTHER THAN THAT WHICH IT WAS  
OBTAINED WITHOUT THE EXPRESSED WRITTEN  
CONSENT OF SAMTEC, INC.

DO NOT SCALE DRAWING

SHEET SCALE: 10:1

F:\DWG\MISC\MKTG\ZF1-XX-XX-WT-XX-MKT.SLDDRW

**SAMTEC**

520 PARK EAST BLVD, NEW ALBANY, IN 47150  
PHONE: 812.944.6733 FAX: 812.948.5047  
e-Mail: [INFO@SAMTEC.COM](mailto:INFO@SAMTEC.COM) CODE: 55322

DESCRIPTION:  
ZERO INSERTION FORCE 1mm ASSEMBLY

DWG. NO. **ZF1-XX-XX-XX-WT-XX**

BY: KEVIN B 9/20/2002 SHEET 2 OF 3

FIG. 2  
 -03 LEAD STYLE  
 (SAME AS FIG. 1, UNLESS OTHERWISE STATED)  
 (ZF1-10-03-T-WT SHOWN)

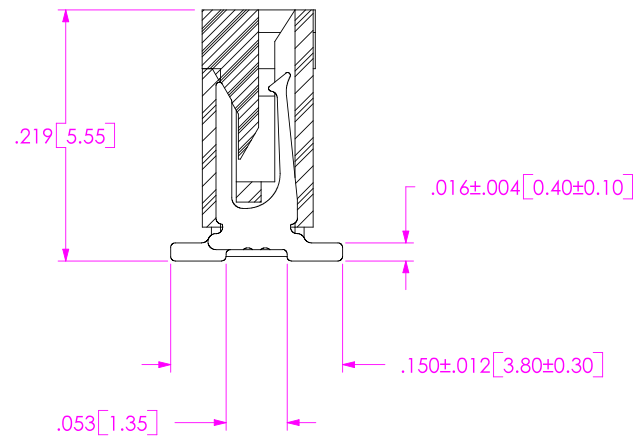
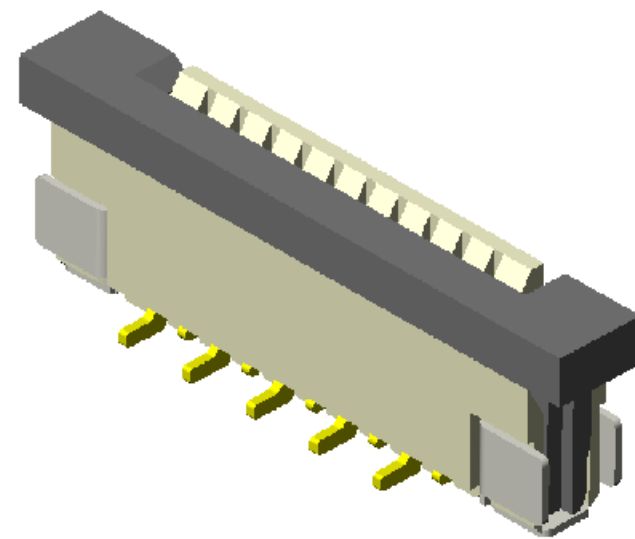
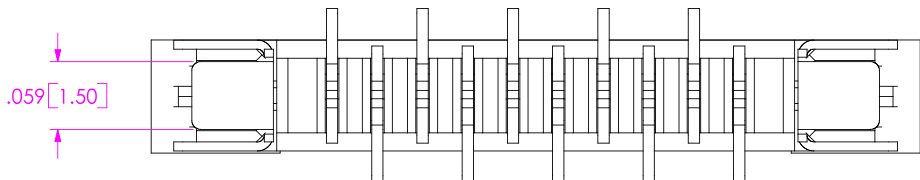
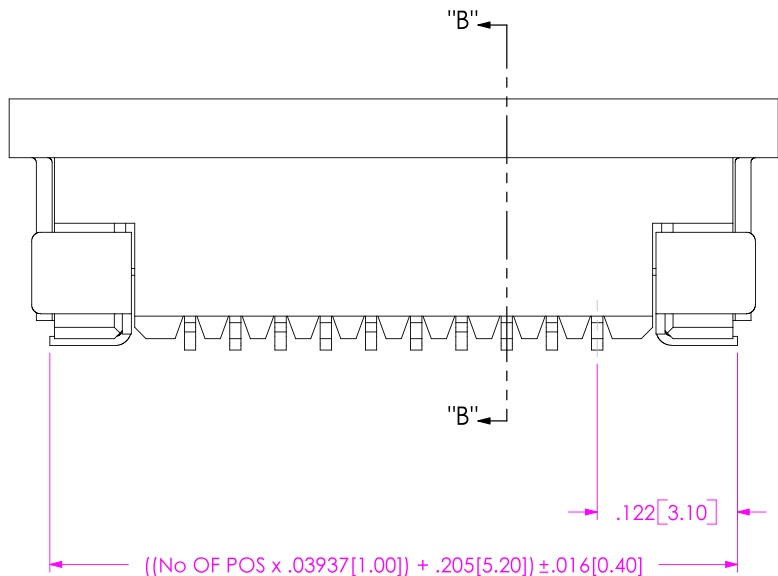
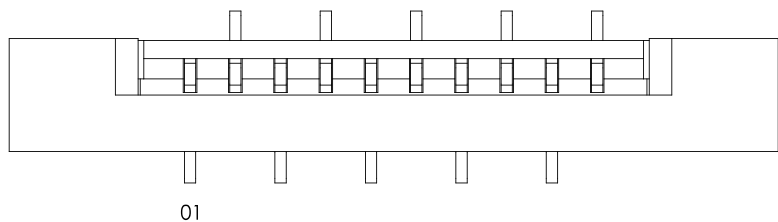

SECTION "B"- "B"

<p><b>PROPRIETARY NOTE</b>                  THIS DOCUMENT CONTAINS INFORMATION CONFIDENTIAL AND PROPRIETARY TO SAMTEC, INC. AND SHALL NOT BE REPRODUCED OR TRANSFERRED TO OTHER DOCUMENTS OR DISCLOSED TO OTHERS OR USED FOR ANY PURPOSE OTHER THAN THAT WHICH IT WAS OBTAINED WITHOUT THE EXPRESSED WRITTEN CONSENT OF SAMTEC, INC.</p> <p>DO NOT SCALE DRAWING</p> <p>SHEET SCALE: 6:1</p>	<p><b>SAMTEC</b></p> <p>520 PARK EAST BLVD, NEW ALBANY, IN 47150                  PHONE: 812.944.6733 FAX: 812.948.5047                  e-Mail: <a href="mailto:INFO@SAMTEC.COM">INFO@SAMTEC.COM</a> CODE: 55322</p>		
	<p>DESCRIPTION:                  ZERO INSERTION FORCE 1mm ASSEMBLY</p> <p>DWG. NO.                  ZF1-XX-XX-XX-WT-XX</p>		
	BY: KEVIN B	9/20/2002	SHEET 3 OF 3