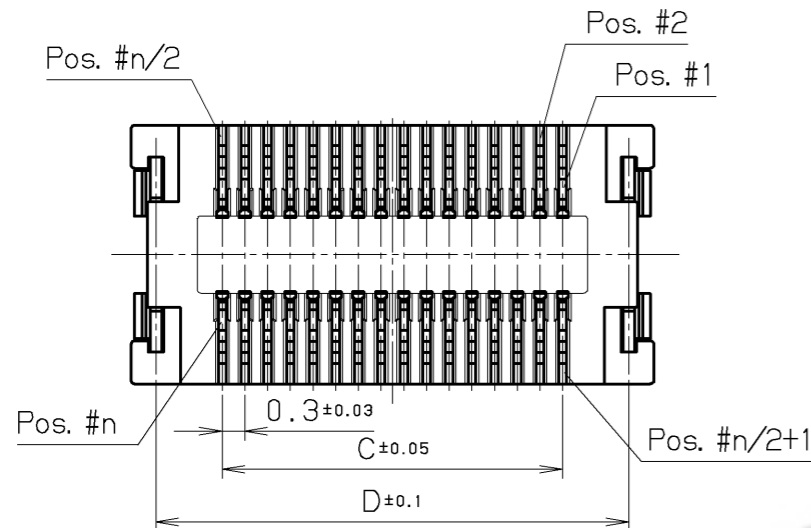
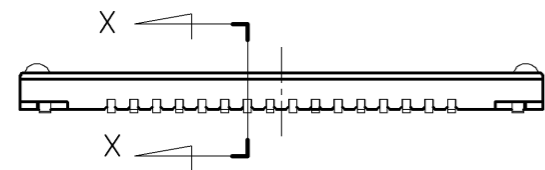
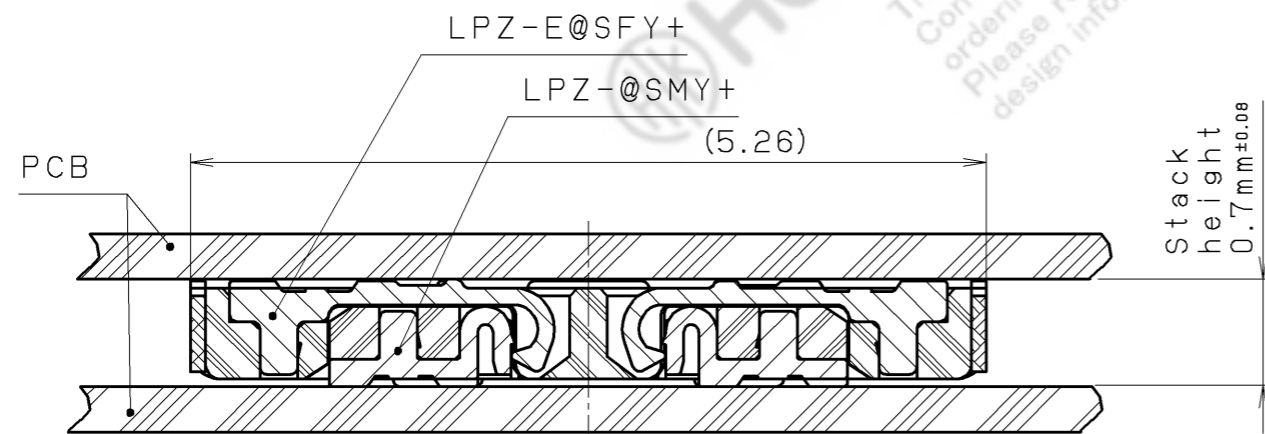
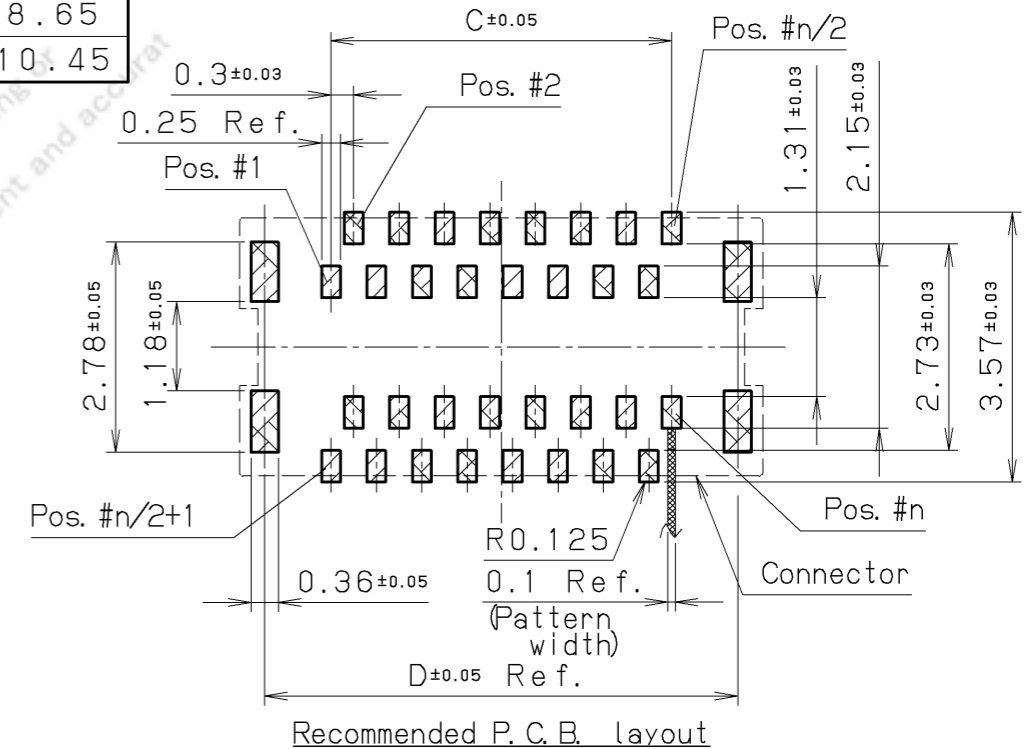

Table-1

Part No.	n	A	B	C	D
LPZ-24SMY+	24	5.71	3.96	3.3	5.05
LPZ-32SMY+	32	6.91	5.16	4.5	6.25
LPZ-40SMY+	40	8.11	6.36	5.7	7.45
LPZ-48SMY+	48	9.31	7.56	6.9	8.65
LPZ-60SMY+	60	11.11	9.36	8.7	10.45



- Note 1. Contact Plating
 Contact area: Gold 0.1μm
 Terminal area: Gold flash
 Underplating: Nickel
 (Under the use of N2-reflow excluded.)
2. Mating Connector
 P/N: LPZ-E()SFY+
3. Contact and Hold down co-planarity is 0.08mm MAX.



△ Mating detail (Reference)

RoHS compliant

△				3	Hold down	Copper alloy	2	Gold flash	
△	Apr. 26 2007	K. K	Pos. 48 added.	2	Contact	Copper alloy	n	See Note #1	
△	Dec. 29 2006	K. K	Mating detail added.	1	Insulator	LCP (GF)	1		UL94V-0 Black
改版	年月日	変更者	変更内容	番号	部品名称	材質	個数	処理	備考
LTR.	DATE	BY	REV. DESCRIPT	No.	PART NAME	MATERIAL	QTY	FINISH	NOTE
年月日	DATE	尺度	SCALE	単位	UNIT	3角法			
Jly. 21 (2006)		10/1		mm (INCH)		3RD. A. P			
製	設	計	検	図	承	本多通信工業株式会社			
DR.	DE.	CHK.	CHK.	APP.		HONDA TSUSHIN KOGYO CO., LTD.			
K. KUWANA	K. KUWANA	K. TAKAHASHI		K. KASAI		名称	0.3mm pitch stacking plus connector SMT termination type (Stack height is 0.7mm)		
						製	番	LPZ-()SMY+	
						PART NO.		REV. 2B	

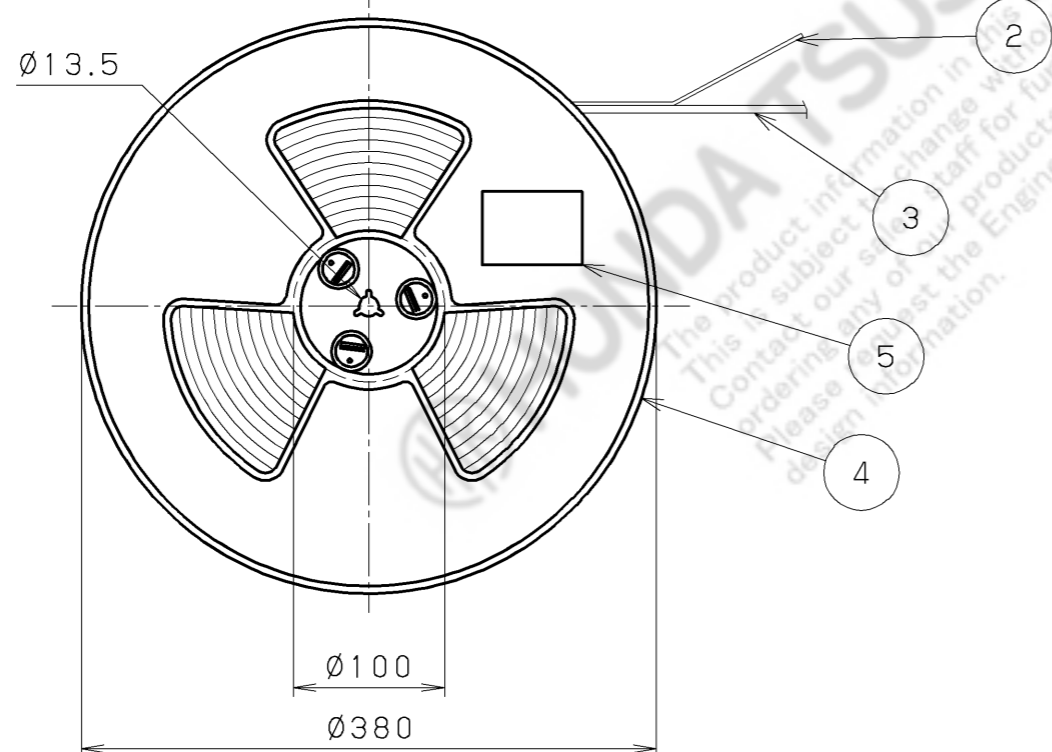
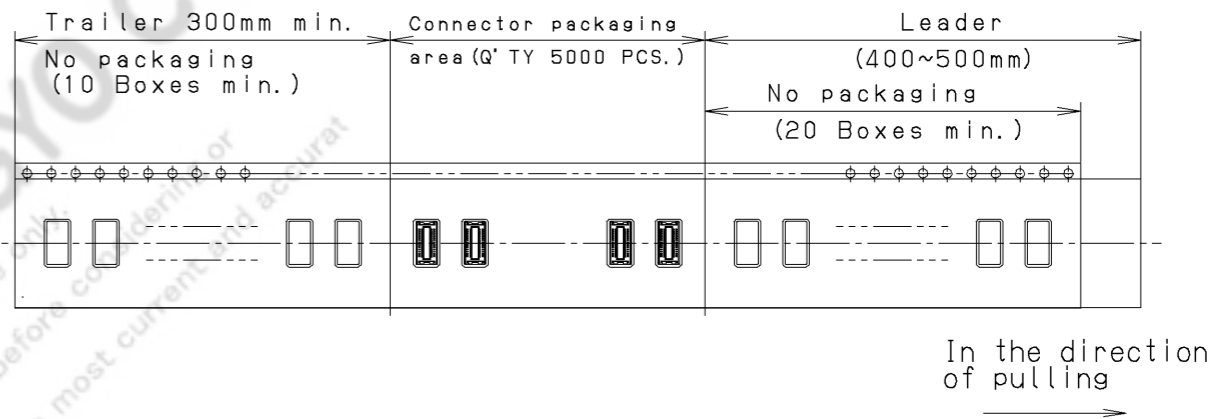
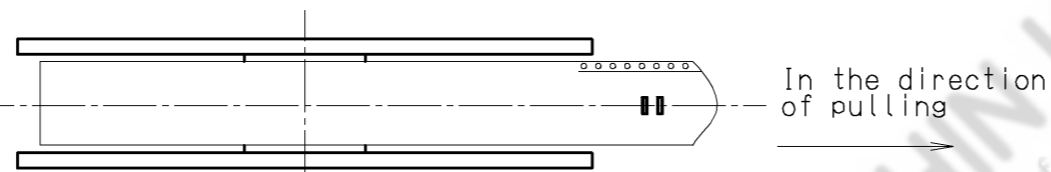
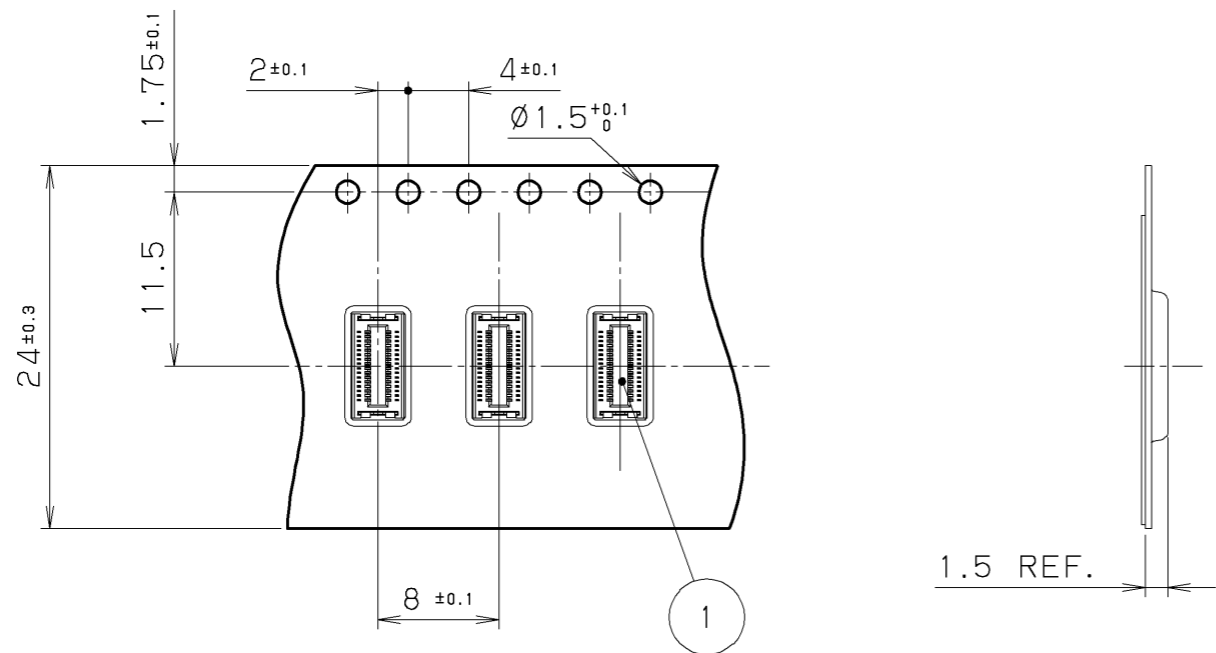

RoHS compliant

△3					5	Label	Paper	1		
△2					4	Reel	PS	1		
△1					3	Embossed tape	PS	1		
					2	Cover tape	PET	1		
					1	Connector		5000		LPZ-32SMY+
改版 LTR.	年月日 DATE	変更者 BY	変更内容 REV. DESCRIPT	番号 No.	部品名称 PART NAME	材質 MATERIAL	個数 QTY	処理 FINISH	備考 NOTE	
年月日 DATE	May.28 (2007)				3角法 3RD. A. P	本多通信工業株式会社 HONDA TSUSHIN KOGYO CO., LTD.				
製図 DR.	設計 DE.	計検 CHK.	図検 CHK.	承認 APP.	名称 NAME	0.3mm Pitch vertical stacking plug connector with embossed tape package (Stacking height is 0.7mm) (RoHS)				
K. KUWANA	K. KUWANA	K. TAKAHASHI		K. KASAI	製番 PART NO.	LPZ-32SMY-TP+ Rev.				

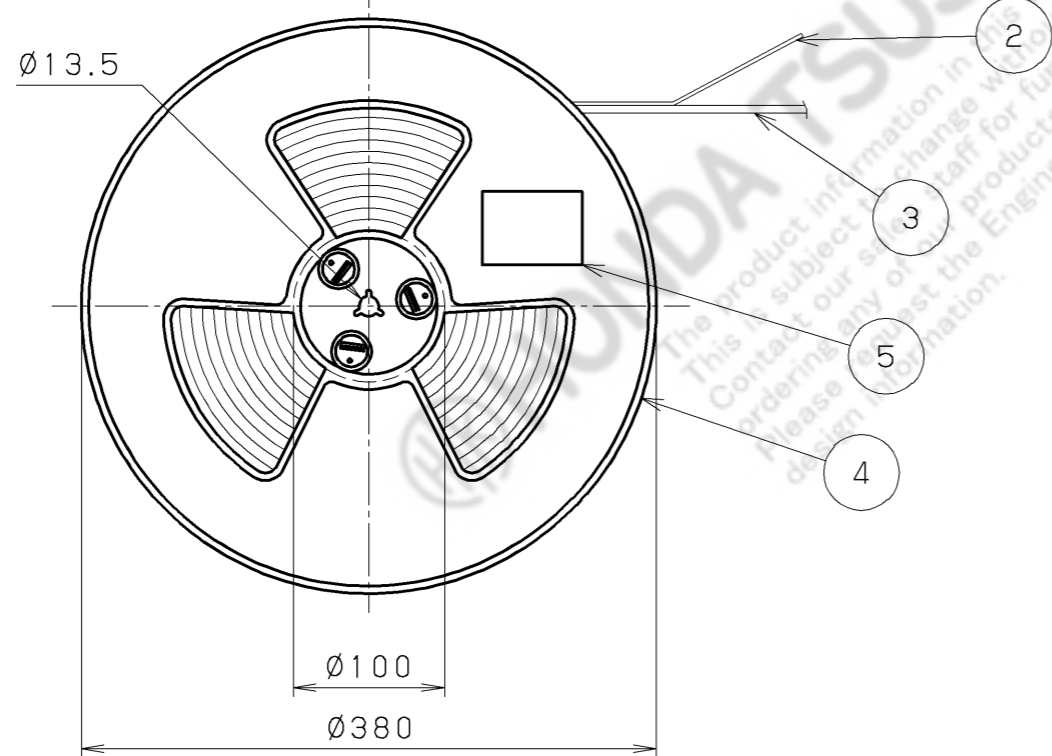
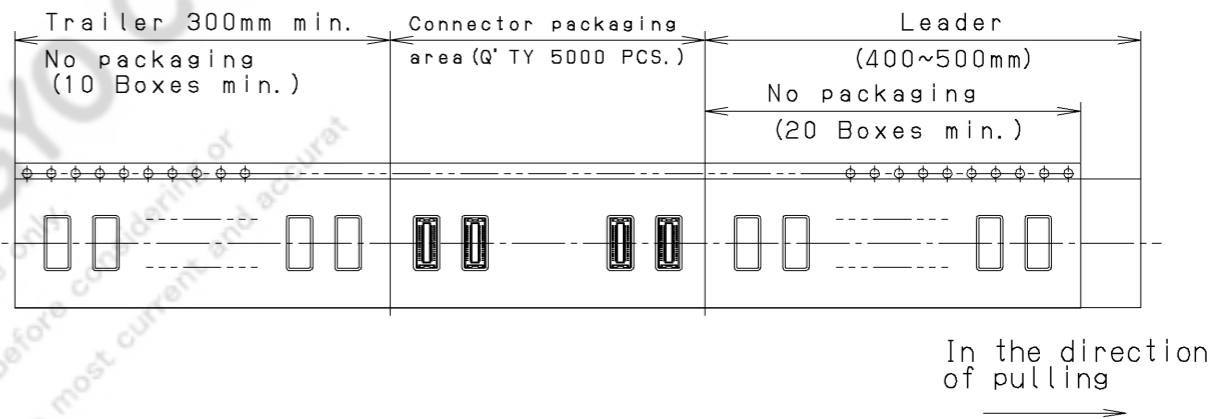
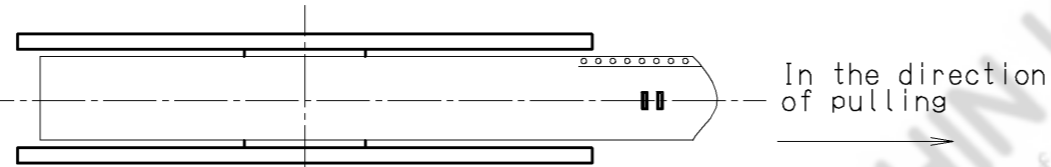
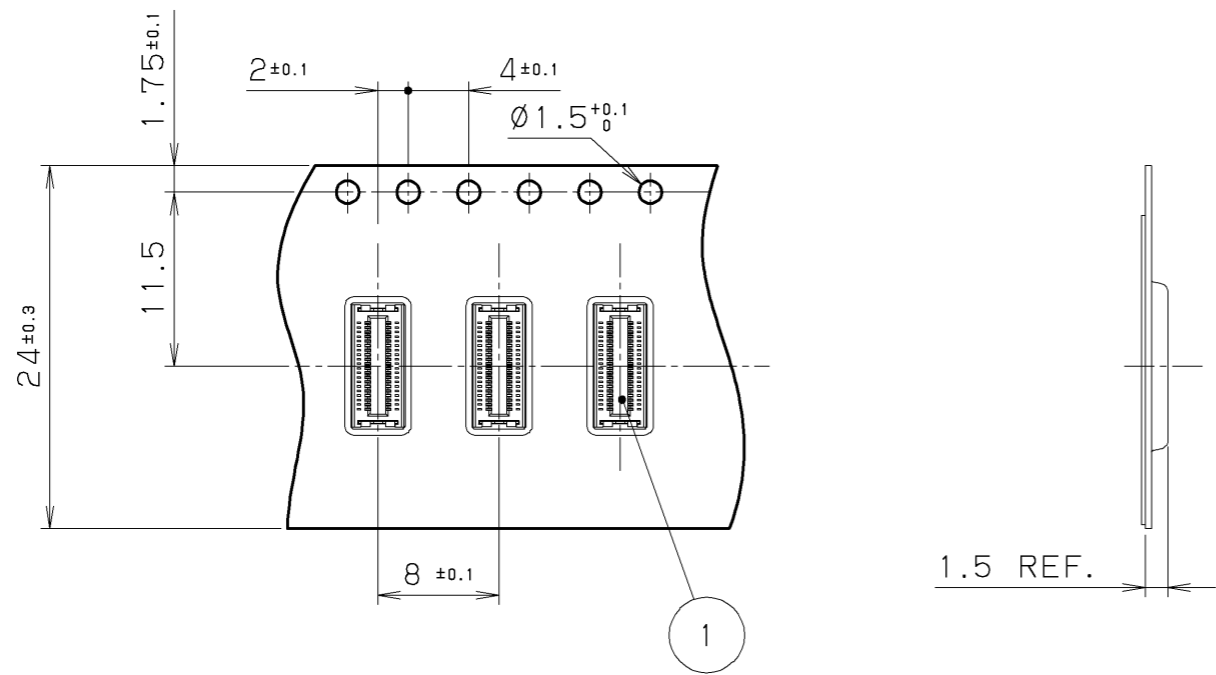

RoHS compliant

△3					5	Label	Paper	1	—	—
△2					4	Reel	PS	1	—	—
△1					3	Embossed tape	PS	1	—	—
					2	Cover tape	PET	1	—	—
					1	Connector	—	5000	—	LPZ-40SMY+
改版 LTR.	年月日 DATE	変更者 BY	変更内容 REV. DESCRIPT	番号 No.	部品名称 PART NAME	材質 MATERIAL	個数 QTY	処理 FINISH	備考 NOTE	
年月日	DATE	尺度	SCALE	単位	UNIT	3角法	本多通信工業株式会社 HONDA TSUSHIN KOGYO CO., LTD.			
Oct.10 (2007)			×	mm (INCH)	3RD. A. P	名称 NAME				
製 DR.	設 DE.	計 CHK.	検 CHK.	承 APP.	0.3mm Pitch vertical stacking plug connector with embossed tape package (Stacking height is 0.7mm) (RoHS)					
K. KUWANA	K. KUWANA	K. TAKAHASHI	—	K. KASAI	製 PART NO.	LPZ-40SMY-TP+		番 Rev.		

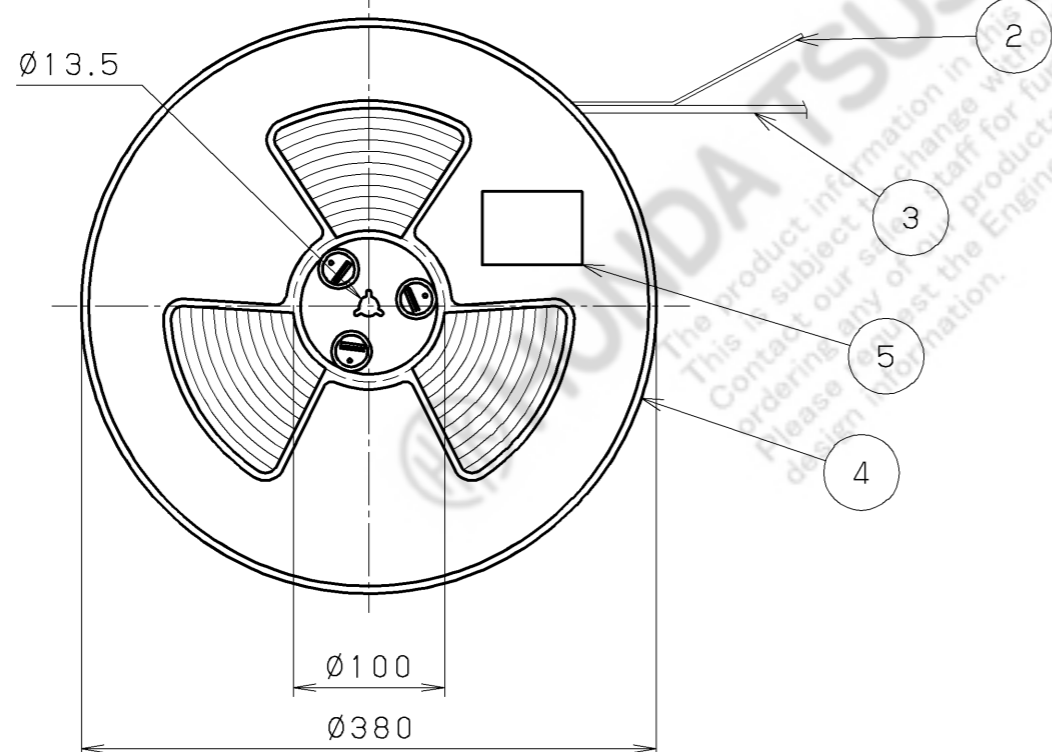
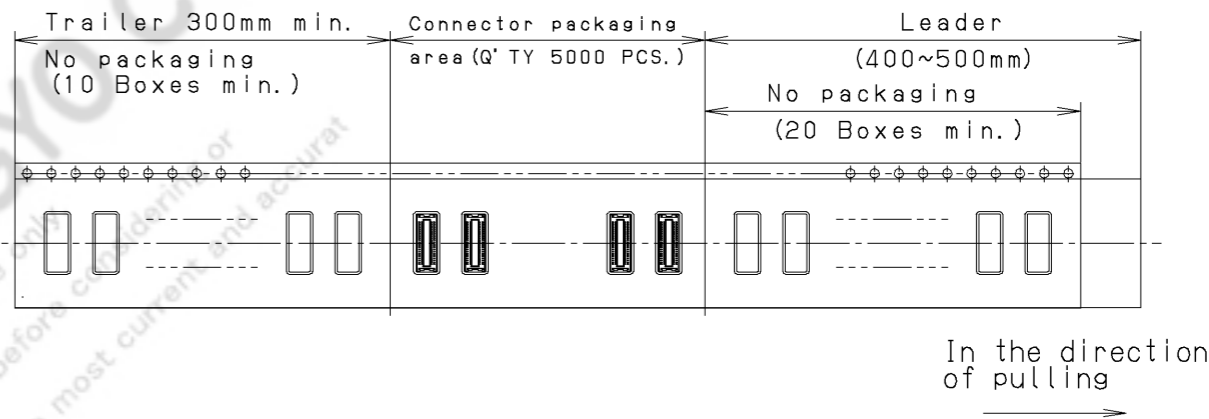
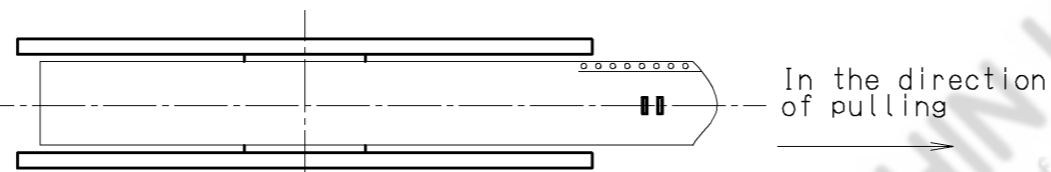
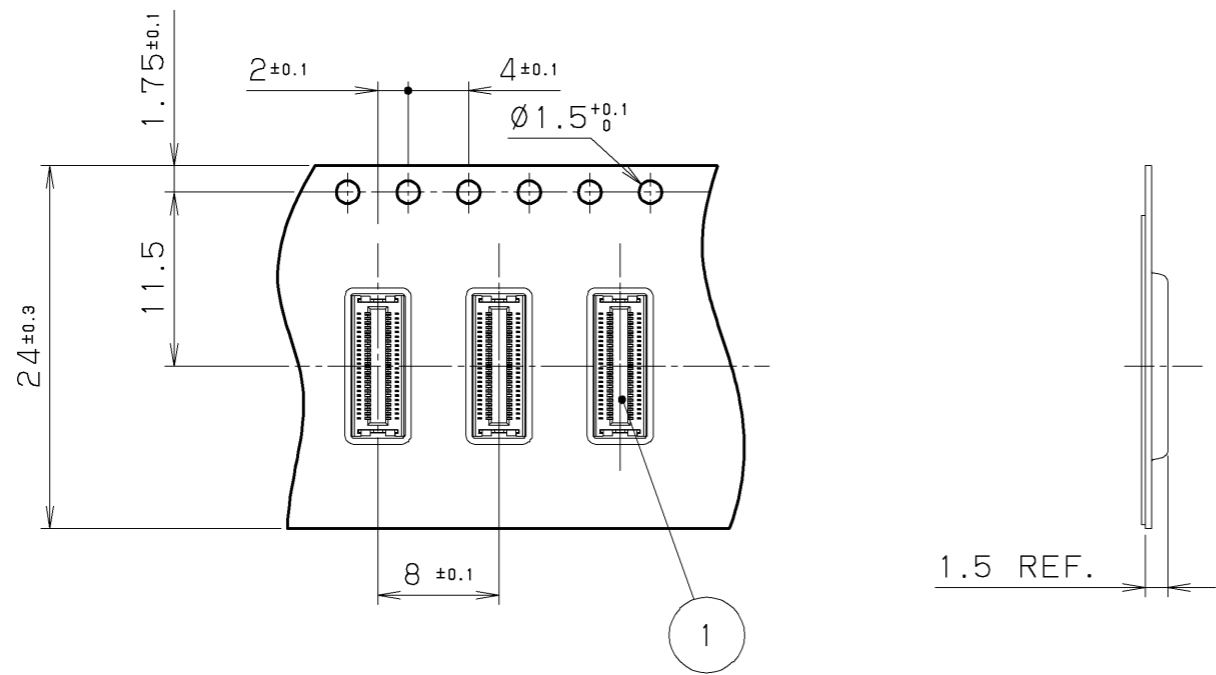

RoHS compliant

△3					5	Label	Paper	1	—	—
△2					4	Reel	PS	1	—	—
△1					3	Embossed tape	PS	1	—	—
					2	Cover tape	PET	1	—	—
					1	Connector	—	5000	—	LPZ-48SMY+
改版 LTR.	年月日 DATE	変更者 BY	変更内容 REV. DESCRIPT	番号 No.	部品名称 PART NAME	材質 MATERIAL	個数 QTY	処理 FINISH	備考 NOTE	
年月日 DATE	尺度 SCALE	単位 UNIT	3角法	本多通信工業株式会社 HONDA TSUSHIN KOGYO CO., LTD.						
Apr.26 (2007)	mm (INCH)	3RD. A. P		名称 0.3mm Pitch vertical stacking plug connector with embossed tape package (Stacking height is 0.7mm) (RoHS)						
製 DR.	設 DE.	計 CHK.	検 CHK.	承 APP.	名 NAME		製 番 PART NO.			
K. KUWANA	K. KUWANA	K. KASAI	—	K. OHNISHI	LPZ-48SMY-TP+		Rev.			

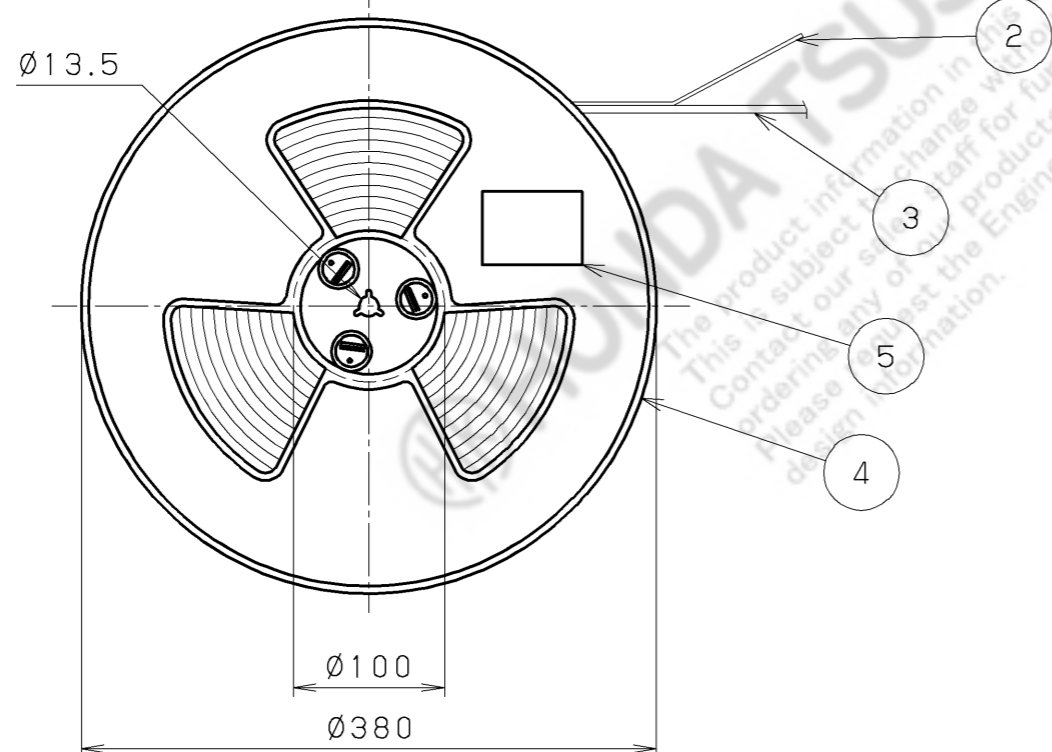
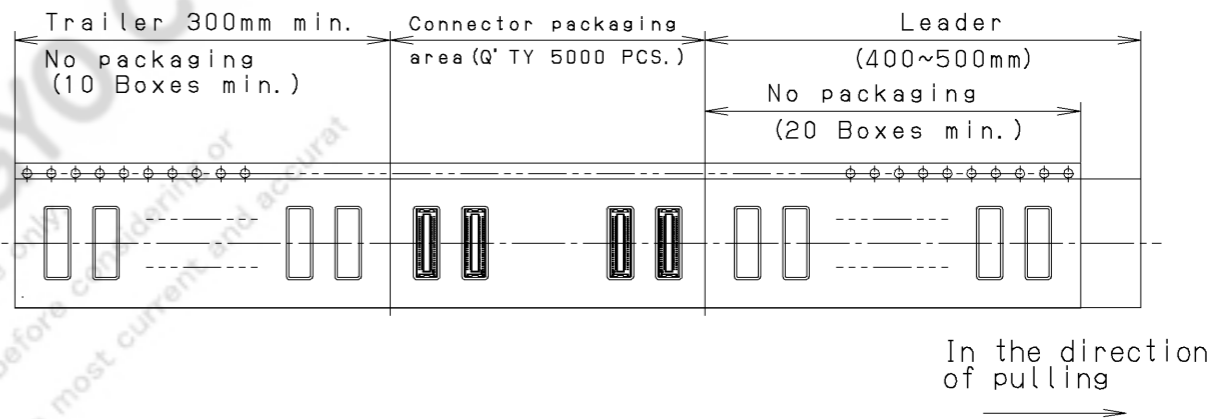
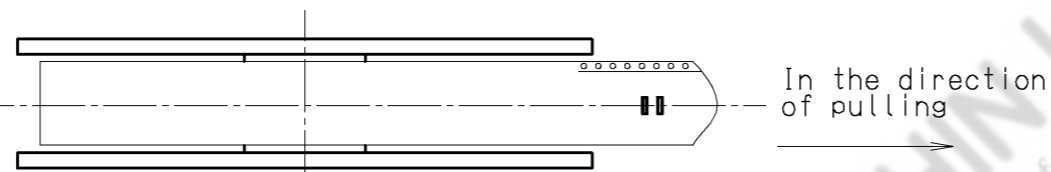
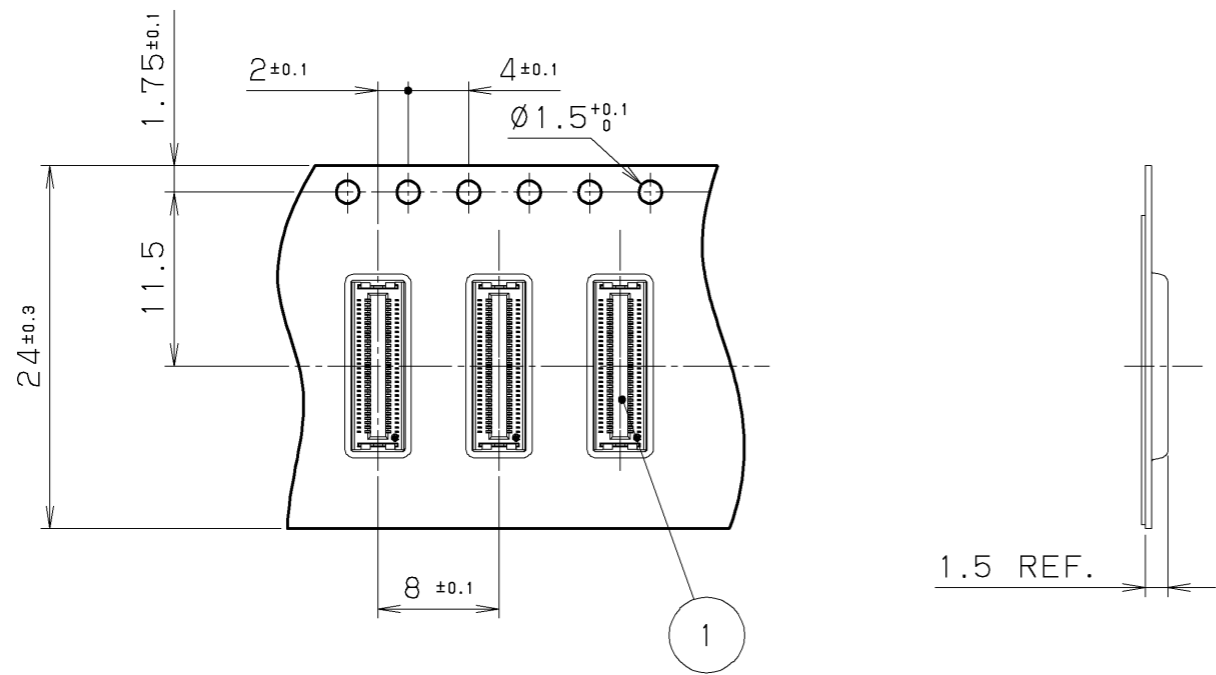

RoHS compliant

					5	Label	Paper	1		
					4	Reel	PS	1		
					3	Embossed tape	PS	1		
					2	Cover tape	PET	1		
					1	Connector		5000		LPZ-60SMY+
改版 LTR.	年月日 DATE	变更者 BY	变更内容 REV. DESCRIPT	番号 No.	部 品 名 称 PART NAME	材 质 MATERIAL	個 数 QTY	処 理 FINISH	備 考 NOTE	
年月日	DATE	尺 度	SCALE	单 位	UNIT	3 角 法	本 多 通 信 工 业 株 式 有 限 公 司 HONDA TSUSHIN KOGYO CO., LTD.			
Feb.21 (2007)				mm (INCH)	3RD. A. P		名 称 NAME			
製 図 DR.	設 計 DE.	計 画 CHK.	検 査 CHK.	承 認 APP.	名 称 NAME		0.3mm Pitch vertical stacking plug connector with embossed tape package (Stacking height is 0.7mm) (RoHS)			
K. KUWANA	K. KUWANA	K. KASAI		K. OHNISHI	製 番 PART NO.	番 号 PART NO.	LPZ-60SMY-TP+	Rev.		