

Self-Cooled High Power Amplifier

LZY-1

50Ω 50W 20 to 512 MHz

Features

- saturated power 50W typ.
- high power with low distortion, -32 dBc typ.
- wide bandwidth, usable 10 - 525 MHz
- high gain, 42 dB typ.
- unconditionally stable
- self protected against excessive drive, high case temp., reverse polarity and shorting/unshorting transients at dc input
- electronic shutoff by grounding the shut-off terminal, reduces output by 50 dB
- open circuiting terminal restores full power within 40 ms
- cool operation with integral fan, 15° C typ. rise
- graceful degradation, +20 to +30V DC
- can withstand short and open circuit at output for 2 minutes while delivering 20 watts

Applications

- AM/FM
- multi-carrier amplification
- broadband swept signal
- feed forward
- linear pulse



CASE STYLE: BT412

Connectors	Model	Price	Qty.
SMA	LZY-1	\$1995.00 ea.	(1-9)

High Power Amplifier Electrical Specifications

MODEL NO.	FREQUENCY (MHz)		GAIN (dB)		MAXIMUM POWER (dBm)			DYNAMIC RANGE		VSWR (:1)		DC POWER	
	f _l	f _u	Min.	Flatness Max.	Output (1 dB Compr.) Min.	Max. Output Typ.	Max. Input (no damage)	NF (dB) Typ.	IP3 (dBm) Typ.	In	Out	Volt (V)	Max. Current** (A)
LZY-1	20	512	39	±1.5	+44	+47	+10	8.6*	+54	2.0	†	+26	7.3

* 80-512 MHz, at 20 MHz 11.6 dB typ.

** At 25W output including operation of fan.

† VSWR, 9.0:1 typ up to 450 MHz, all specifications for 50 ohm load.

Open load is not recommended, potentially can cause damage.



To order without heat sink and fan, add suffix-X to model number. Alternative heat sinking and heat removal must be provided by customer to ensure proper performance. See application note AN-60-004. Deduct \$100 from price list

Maximum Ratings

Operating Temperature -10°C to 50°C

Storage Temperature -55°C to 100°C

DC Voltage +30V Max.

Outline Drawing

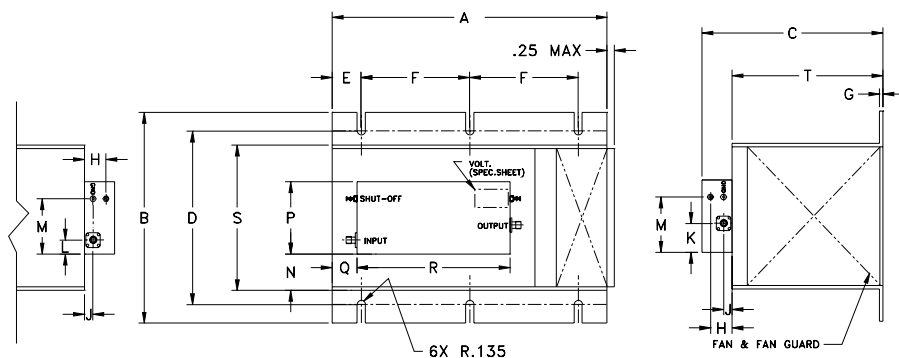

Outline Dimensions (inch/mm)

A	B	C	D	E	F	G	H	J										
9.50	7.3	6.3	6.00	.98	3.75	.13	.75	.30										
241.30	185.42	160.02	152.40	24.89	95.25	3.30	19.05	7.62										
									K	L	M	N	P	Q	R	S	T	wt
									1.00	.48	1.91	1.3	2.50	.9	5.30	5.1	5.2	grams
									25.40	12.19	48.51	33.02	63.50	22.86	134.62	129.54	132.08	4000



INTERNET <http://www.minicircuits.com>

P.O. Box 350166, Brooklyn, New York 11235-0003 (718) 934-4500 Fax (718) 332-4661

Distribution Centers NORTH AMERICA 800-654-7949 • 417-335-5935 • Fax 417-335-5945 • EUROPE 44-1252-832600 • Fax 44-1252-837010

Mini-Circuits ISO 9001 & ISO 14001 Certified

REV. OR
M98211
LZY-1
051208
Page 1 of 2

FREQUENCY (MHz)	GAIN (dB)			DIRECTIVITY (dB)			VSWR (:1)		POUT at 1 dB COMPR. (dBm)	NOISE FIGURE (dB)
	23V	26V	27V	23V	26V	27V	IN	OUT	26V	26V
20.00	44.00	43.91	43.77	23.33	18.53	18.11	1.22	1.30	46.30	11.81
45.00	43.79	43.71	43.57	11.17	10.78	30.20	1.29	1.15	46.42	10.05
70.00	43.61	43.54	43.41	7.23	24.02	14.59	1.35	1.25	47.24	9.37
95.00	43.42	43.36	43.24	17.29	25.52	9.62	1.42	1.33	48.21	9.02
120.00	43.37	43.32	43.20	10.80	28.46	10.74	1.46	1.34	48.69	8.84
145.00	43.32	43.27	43.15	8.42	29.48	13.93	1.48	1.28	48.80	8.75
170.00	43.33	43.27	43.16	10.03	16.43	24.07	1.49	1.15	48.37	8.70
195.00	43.53	43.49	43.37	14.83	12.25	25.41	1.48	1.14	48.45	8.73
220.00	43.62	43.60	43.50	7.23	12.07	28.19	1.48	1.40	47.85	8.82
245.00	43.51	43.53	43.44	9.90	23.38	24.25	1.47	1.81	47.29	8.85
270.00	43.55	43.59	43.50	4.22	16.46	18.21	1.44	2.30	46.84	8.91
295.00	43.65	43.72	43.64	16.19	24.50	14.28	1.37	2.86	46.67	8.96
320.00	43.81	43.89	43.82	21.60	11.91	18.66	1.25	3.48	46.48	8.93
345.00	44.19	44.30	44.23	11.14	17.33	17.71	1.11	4.34	46.19	8.86
370.00	44.32	44.49	44.42	7.98	18.54	17.17	1.07	5.47	45.64	8.80
395.00	43.90	44.09	44.02	17.36	9.91	9.65	1.12	6.03	45.17	8.70
420.00	43.13	43.32	43.25	20.54	15.46	25.19	1.08	5.39	45.17	8.60
445.00	42.65	42.81	42.74	15.90	9.73	17.76	1.06	4.59	45.43	8.40
470.00	42.56	42.68	42.61	16.10	26.90	12.62	1.20	4.41	45.38	8.19
512.00	43.38	43.51	43.42	6.69	15.73	21.49	1.48	13.09	46.00	7.78

