

EDC100

External Digital Controller EDC100

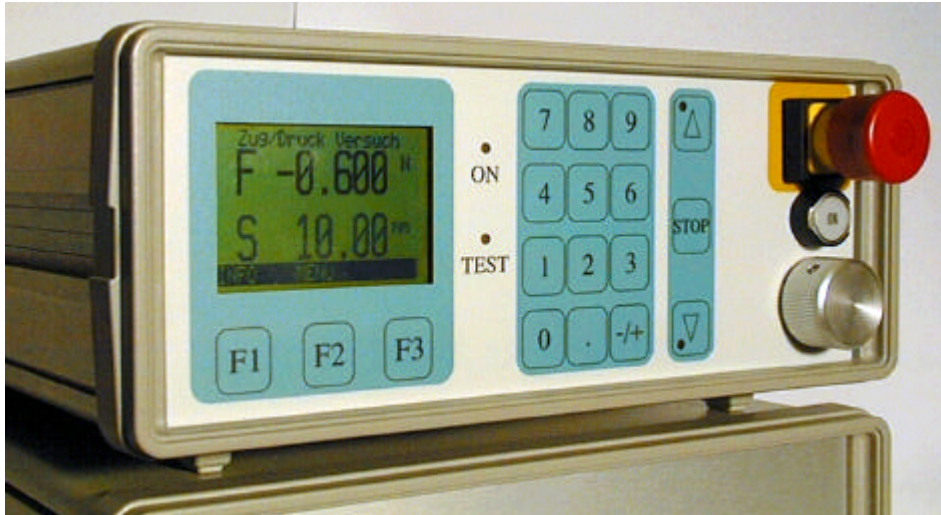

EDC100 on top of a DDA04 (500W) /05 (1000W) power amplifier. All electronics you need for a e.g. up to 100 kN testing instrument

EDC100 System Overview:

The EDC100 electronics from DOLI is a powerful and cost effective system which is designed especially for testing instruments. Considering its power and possibilities, the EDC100 is settled above the EDC5/25 electronics from DOLI. The unit distinguishes itself the high load- resolution with ± 100.000 steps, the bus-system for an extension up to eight option boards and the high CPU capacity for fast Controller calculations.

The electronics fits for:

screw instruments with a specially adapted DOLI power amplifier for motors of **90 Watt, 500, 1000 and 2200 Watt.**

screw instruments with more power are driven by an ± 10 Volt output as well as the necessary control-signals to drive an external power amplifier.

hydraulic instruments, which are driven by a proportional- or servo-valve.

The EDC100 electronics can be driven with or without a PC. The casing box version has a local display and function keys for input and to move the instrument. A printer or a PC can be connected optionally.

Zentrale, Verwaltung, Entwicklung:

Lieferadresse:
 DOLI Elektronik GMBH
 Fraunhoferstrasse 23h
 D-80469 München
 Tel. 089-20 243-0
 e-mail: info@doli.de

Postadresse:

DOLI Elektronik GMBH
 Postfach 14 02 40
 D-80452 München
 Fax. 089-20 243 243

Vertrieb:

DOLI Elektronik GMBH
Mühlstraße 26
D-55271 Stackeden-Elsheim
Tel. 06130-944 250
Fx. 06130-944 251
e-mail: sales@doli.de

Fertigung:

DOLI Elektronik GMBH
 Ulmer Straße 34
 D-89584 Ehingen
 Tel. 07391-34 21
 Fx. 07391-56 80
 e-mail: ehi@doli.de

Deutsche Bank München

BLZ 700 700 10, Kto 307 52 07
 Münchner Bank eG
 BLZ 701 900 00, Kto 20540

HRB München 5 24 56
 Ust-ID-Nr. DE 129 329 359

Internet: <http://www.doli.de>

Geschäftsführende Gesellschafter:
 Ernst Ams, Michael Grupp
 Gesellschafter:
 Klaus Böck, Rolf Grupp
 Hermann Schabel, Harald Schmid

EDC100

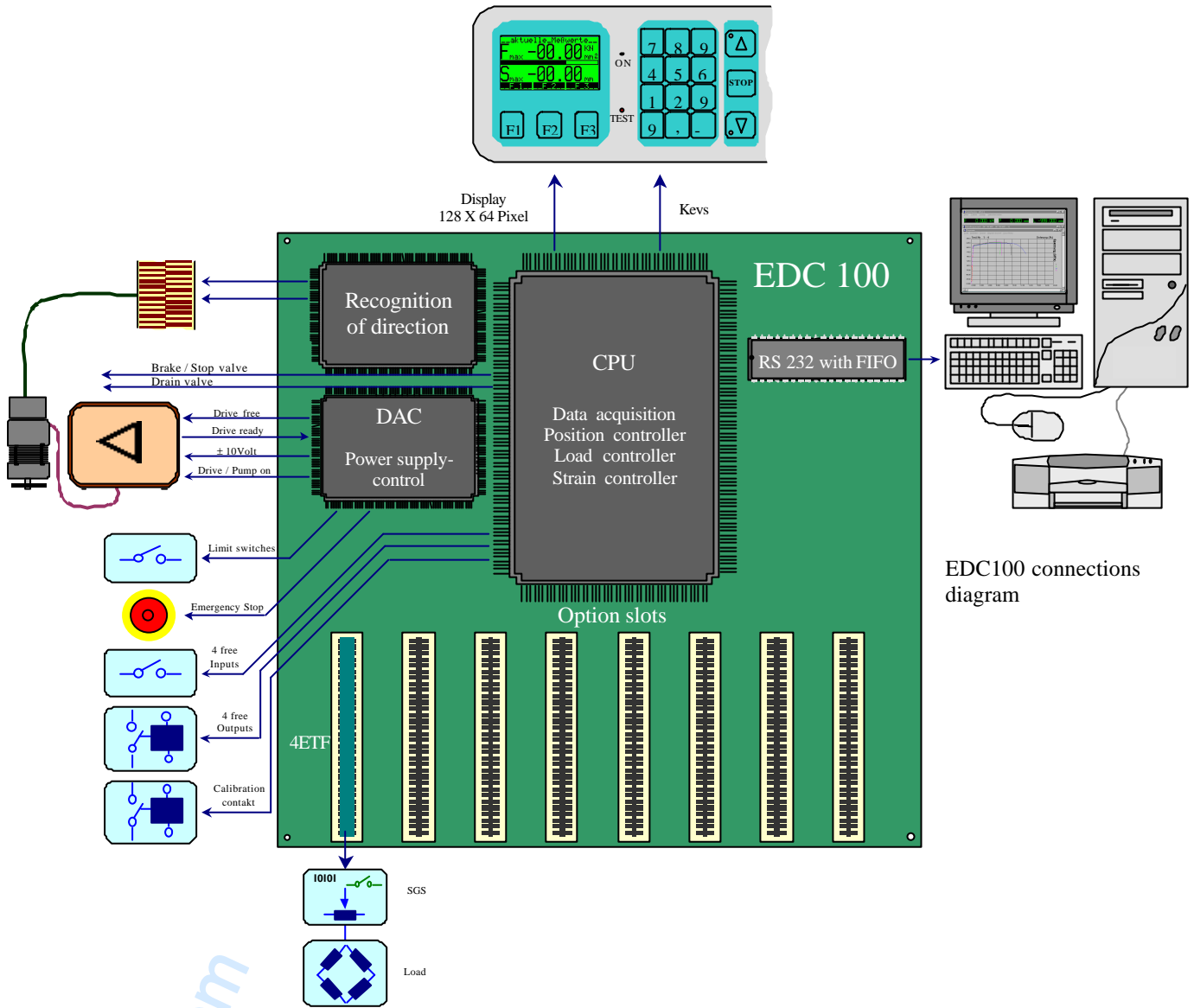

EDC100 connections diagram

Definition

EDC100 = Load resolution ± 100.000 steps

total ± 140.000 steps, the steps above 100.000 are used for a safe control in case of an overshoot or reaching a limit of the instrument.

EDC100

External Digital Controller EDC100, Page 3

Possible System Versions:

EDC100 as standalone system:

Display, keys and printer are served from the EDC100. A basic data analysing program is on board. User programs are available for:

- „Soft Materials“, such as rubber, plastic, food etc.
- „Hard Materials“, such as metal, plastics etc.
- „Concrete materials“ as used in the building testing environment.



EDC100 the Interface to the PC:

The system is served completely by the PC. Display and function keys are still active at the EDC100. The printer is connected to the PC.



In case of a service, the second serial interface is used for communication. The field-service is able to talk to the EDC100 e.g. via a Notebook PC. An EPROM change as in former days is not necessary. A communication with a directly connected PC and a modem is imaginable.

EDC100

External Digital Controller EDC100, Page 4

Possibilities with different Testing Instruments:

Version 1: 90W

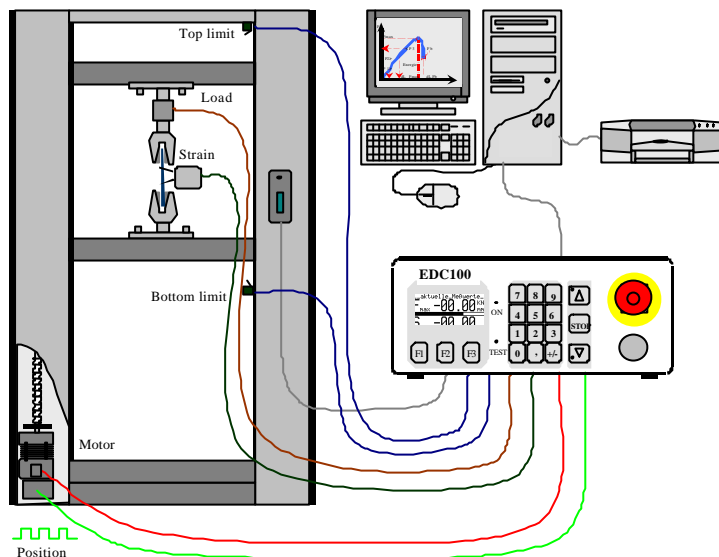

- digital Position- Load- Strain-Control
- direct drive of a motor with max. 30 V / 3 A by the PCB,
- the limit switches have an effect directly to the power amplifier,
- load resolution ± 100.000 steps,
- incremental transducer for X-Head travel

Version 2: 500/1000/2200W

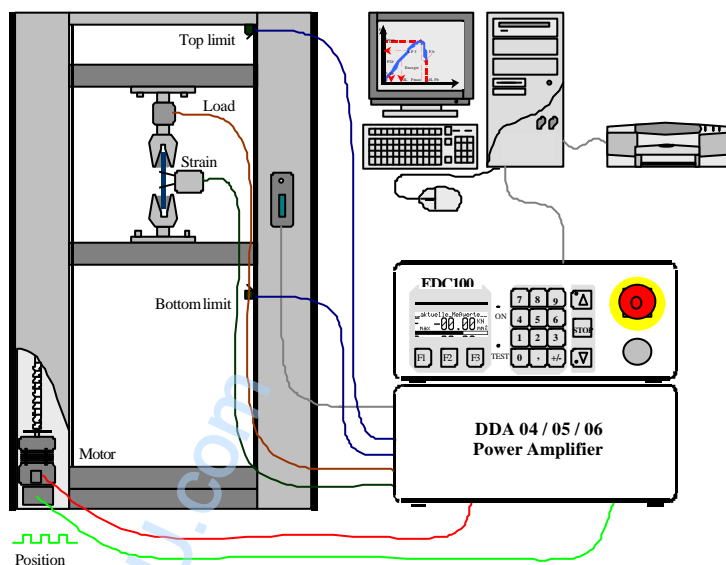

- digital Position- Load- Strain-Control
- direct drive of a motor with 105 Volt 11 A (max. 500 W) or 105 Volt 11 A (max. 1000 W) or or 150 Volt 15 A (max. 2200 W)
- the limit switches have an effect directly to the power amplifier,
- load resolution ± 100.000 steps,
- incremental transducer for X-Head travel.

EDC100

External Digital Controller EDC100, Page 5

Version 3: 10V

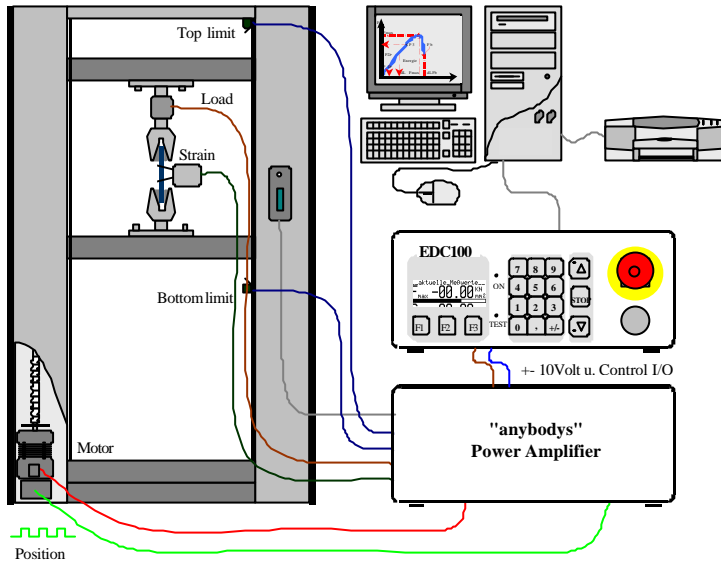

- digital Position- Load- Strain-Control
- drive of an external power amplifier with ± 10 Volt,
- control I/O for drive 'free', drive 'ready', drive 'on' and brake.
- load resolution ± 100.000 steps.
- incremental transducer for X-Head travel.

Version 4: Hydraulic

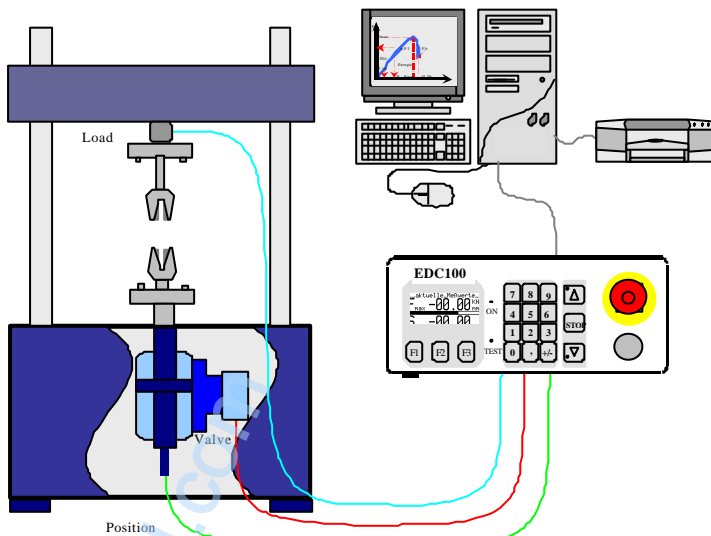

- digital Position- Load- Strain-Control
- current controlled drive of a proportional- or a servo-valve,
- control I/O for drive 'free', drive 'ready', pump 'on' and stop and drain-valve,
- load resolution ± 100.000 steps.
- actuator displacement resolution ± 100.000 steps.

EDC100

External Digital Controller EDC100, Page 6

Description:

Processor:

- 80386EX CPU 25 MHz
- Flash EPROM 256k x 16 with Boot-Block
- CMOS RAM 128k x 16
- 2 KB EEPROM to store machine data

Serial Interface RS232:

- COM1: for PC with FIFO max. Baud rate 115 KB
Break recognition and Reset
- COM2: Debug Interface 9600 Baud

X-Head travel:

- incremental rectangle input with control of 'transducer present' for X-Head travel.
- NOVRAM to store X-Head position.

Extension-Bus I4:

- 8 connectors for systems extensions.
The first connector is occupied by the load channel.

Load measurement:

The load measurement channel is a module (4ETF) on the I4-Bus. This 4ETF is a carrier frequency amplifier especially for strain gauge and inductive transducers (LVDT). The module also allows DC- signal input. The A/D-converter works on voltage/frequency-transformation and is, therefore, integrating.

Amplifier and Supply

- | | |
|--|------------------------------------|
| • Carrier frequency | 5 kHz Sinusoidal |
| • Supply voltage adjustable via software (in Veff) | 1.1 - 2.5 - 5.5 Volt |
| • Transducer sensitivity adjustable via software | 1.16 - 1625 mV / V |
| • Internal resistance transducer | $\geq 85 \Omega$ |
| • Source resistance signal source (CF operation) | $\leq 1.1 k\Omega$ |
| • Source resistance external reference (CF operation) | $\leq 1.1 k\Omega$ |
| • DC input adjustable via software | $\pm 5.8 mV - \pm 1.625 V$ |
| • Input resistance (DC measurement) | $> 15 M\Omega$ |
| • Common mode range | $\pm 6.5 V$ |
| • Common mode suppression
(Input amplification.: x3.1; x34.6; x387) | $\geq 80dB, \geq 95dB, \geq 105dB$ |
| • Filter | Bessel Filter 3. degree 100 Hz |

Converter

- | | |
|---|----------------------------------|
| • Type | U/f Converter |
| • Resolution at 20 ms integration time | $\pm 140,000$ parts |
| • Resolution at 250 ms integration time | $\pm 1,770,000$ parts |
| | $\pm 400,000$ parts reproducible |

EDC100

External Digital Controller EDC100, Page 7

- Linearity of amplifier and converter typical 0.01 % (0.025%max)
- Linearity at saturation of max. 20 % ca. 2 %
- Temperature influence per ° Kelvin (CF measurement) Offset 0.001 %/°K
- Display noise: Amplification 0.01 %/°K
 - The value of a connected sensor is allowed to vary non-operative $\pm 0.5\%$ from 0.4% of the nominal value (that equals 2 digits at 100,000). Conditions:
 1. Tester non-operative, integration time 100 ms, load cell unloaded.
 2. Tester runs, integration time 100 ms, load cell not inside the Tester, but connected electrically.

Transducer coding (SGS)

- The sensor plug gives the possibility to store information about the connected transducer in an EEPROM. This information can be read in at switch on or on request.

Actuation Variations:

$\pm 10V$ Output internal, for external Power Amplifiers

- $\pm 10V$ Output to drive external power amplifiers.
- 24 V control I/O for drive free, drive ready, drive on and brake.

90 Watt Power Amplifier internal

- 4 Quadrant power amplifier ca. 30V, 3A
- control with a 8 Bit PWM-Signal (pulse-width-modulation)
- motor at Emergency Stop short-circuited via a resistor
- connection for Emergency Stop and limit-switches
- Emergency Stop and limitswitches are in the current line to the amplifier. If a limit-switch becomes active, it has to be loosen mechanically.

500 Watt Power Amplifier in a separate Housing

- Control with $\pm 10V$ from the EDC100
- Inrush current limitation
- Power Amplifier Data:
 - $I_{\text{rated/max}} = 10A/14A$
 - $V_{\text{max}} = 105V$
 - Maximum power 500 Watt
 - PWM = ca. 20 kHz
- Current controller
- Brake resistant at output
- negative feeder of motor energy at braking back into the intermediate circuit is possible; the controller electronics guaranties the safety low voltage PELV from ($V < 60V$).
- The Power Amplifier supply is disconnected at fault (Emergency Stop, Limit-switches etc.) via a conductor.

EDC100

External Digital Controller EDC100, Page 8

1000 Watt Power Amplifier in a separate housing

- like 500 Watt amplifier but:
- Power Amplifier Data:

$I_{\text{rated/max}}$	=	10A/14A
V_{max}	=	105V
Maximum power		1000 Watt

2200 Watt Power Amplifier in a separate housing

- like 500 Watt amplifier but:
- Power Amplifier Data:

$I_{\text{rated/max}}$	=	15A/20A
V_{max}	=	150V
Maximum power		2200 Watt

Proportional-Valve Amplifier internal

- drive of a Proportional valve nominal current 300 to 3000 mA.
- 24 V control I/O for drive free, drive ready, pump on, Stop- and drain valve.
- adjustable dither frequency and amplitude.

4HYD Hydraulic Servo Valve Amplifier internal

- drive of a servo valve nominal current 20 to 100 mA.
- 24 V control I/O for drive free, drive ready, pump on, Stop- and drain valve.
- adjustable dither frequency and amplitude.

Relaybox 2 concerning safety regulations for external drive units

This box is designed to fit on a top hat rail. All connection to peripheral devices are terminal screws. The box contains a safety relay, to enable an emergency movement in case a limit switch is active. There is also a possibility for an emergency stop from the computer. The box needs an external 24 Volt power supply.

This box is not needed for the DOLI 500, 1000 and 2200 Watt drives, because the safety relevant functionality are already included.

- Connection of an external emergency contact.
- Connection of the limit switches.
- Relay contact for a break.
- Relay contact for a drain valve
- Drive of a power contactor including safety check of the contactor.
- Connection of drive free signal
- Two drive ready inputs
- Connection of the ± 10 Volt control output
- EEPROM to store data of the drive unit.

EDC100

External Digital Controller EDC100, Page 9

RMC (Remote Machine Control):

Handheld unit with cable 3m long, directly connected to the EDC. The control keys UP, DOWN and STOP and a digital poti are on the front. The functions on the RMC and on the equivalent front of the EDC are identically.

Strain extension with 4ETF:

I4 Module; excitation of strain gauge or LVDT transducers; carrier frequency 5kHz; A/D conversion ± 140.000 steps at 20 msec; parameters adjustable via software; the 4ETF Module can be used for a 10 V input with the same resolution of the A/D converter. (specification see load measurement)
Optionally a 10 V analogue output is available e.g. to mix this signal with other strain gauge signals at an X-Y recorder.

Sensor Plug (SGS):

To identify and calibrate transducer as load cells, extensometers etc., a small PCB within a plug case (15 pin SUB-D) is available. The advantage is the use of not calibrated e.g. load cells, because the calibration has to be done in house anyway. The calibration along with other data is stored in the plug. The EDC reads the data at switch on or at request. The features are :

- Reference bridge to adjust the transducer sensitivity
- EEPROM to store transducer data

The cables of the transducer are soldered directly to the PCB. The software to program the EEPROM is delivered also.

EDC100

External Digital Controller EDC100, Page 10

Extension 4INC:

It is used for direct connection of incremental transducers e.g. Extensometer. I/O's allow the control of further equipment e.g. arms and grips of the Extensometer.

- two incremental inputs with digital fourfold of the transducer resolution.
- each channel can be adjusted within the sensorplug to the transducer.
available incremental sensorplugs:

7IS1	for one transducer with sine output with an analogue tenfold
7IS2	for two transducers with sine output with an analogue tenfold
7IT1	for one transducer with TTL output signal
7IT2	for two transducers with TTL output signal
7IL1	for one transducer with line driver output signal
7IL2	for two transducers with line driver output signal

Besides the signal conditioning there is an EEPROM in all of the incremental sensor plugs. Transducer specific data and identification data are stored in this EEPROM.

- six 24 Volt/100 mA outputs
- one relays output
- five 24 Volt/11 mA inputs
- external 24 Volt supply

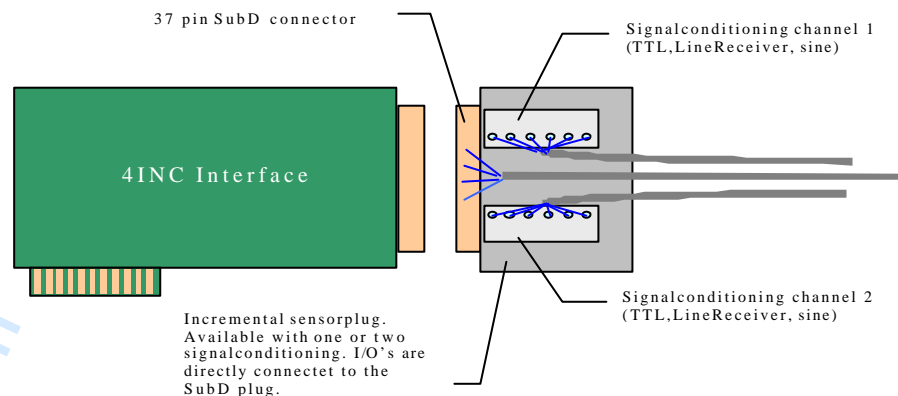

Extension 4IO:

Variation of the 4INC Module to control driven grips etc.

- six 24 Volt/100 mA outputs
- one relays output
- five 24 Volt/11 mA inputs
- external 24 Volt supply

EDC100

External Digital Controller EDC100, Page 11

Casing Box

Front :

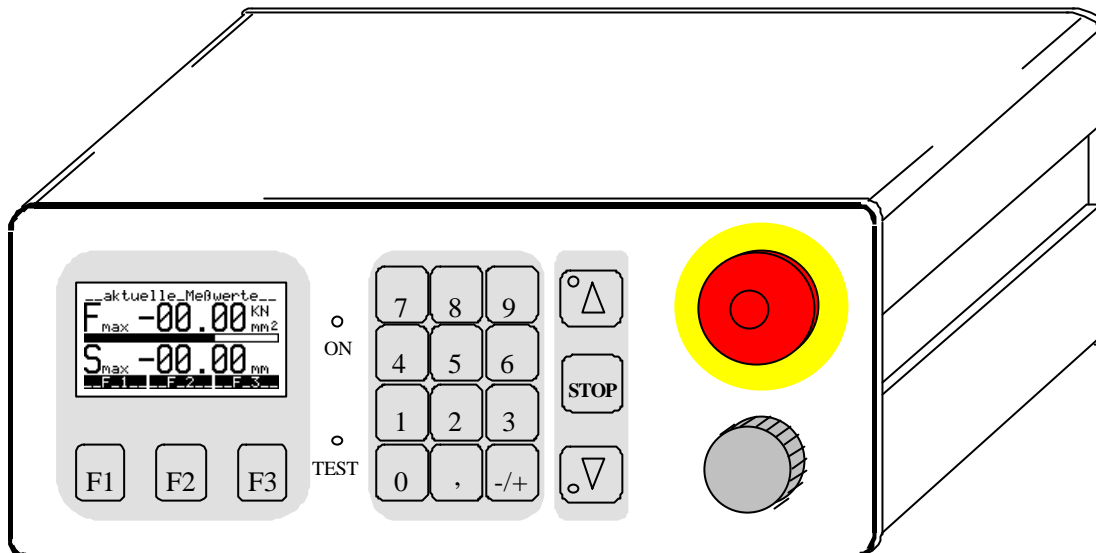

Rear:

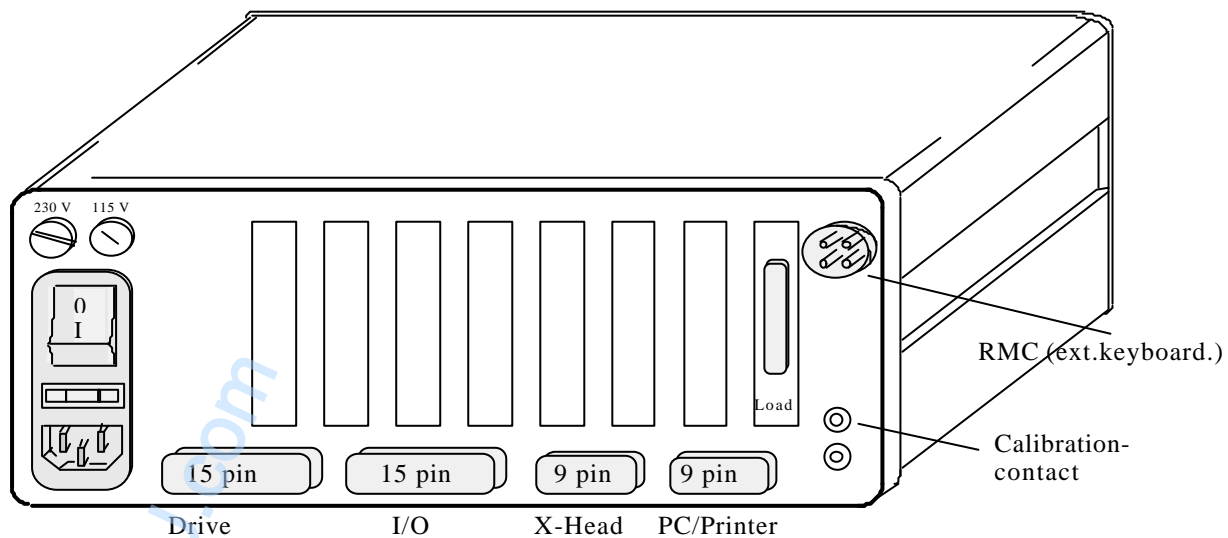

Dimensions: 255x105x325 mm

Connections: at the rear via plug-in connection

Display: LCD-Graphics display
128 x 64 dots

Keys: Up, Down + Stop (machine control)
numerical- and function keys (value
input, programming)

Digi poti: Cross-head/cylinder positioning
Scroll of display and positioning of data input

EDC100

External Digital Controller EDC100, Page 12

Software

The EDC can be operated as “stand alone“ as well as machine control interface in connection with a PC.

The “stand alone“ variant is available either with “soft-“, “hard-“ or “concrete-software“. DOLI also delivers a PC program, which uses the EDC as interface.

This program is called MTPC (Material Test PC). Only the MTPC software shows the on-line graph on the PC monitor. This MTPC-program is also available for “soft-“, “hard-“ or “concrete-“applications.

“Stand alone“-Software

Test Description “Soft“

Tension and Compression Test for Plastic and Rubber

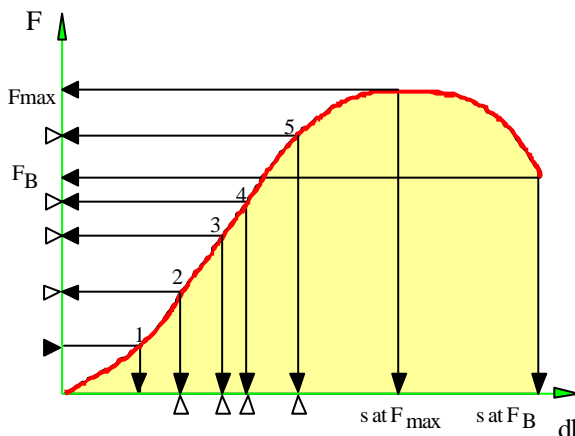

- The specimen will be loaded with constant speed up to break.
- Maximum speed (F_{max}), Break-load (F_b) and the equivalent strain are the results of the test.
- Also, up to 5 points (P1..P5) can be placed either at X or Y in the diagram and the program will calculate the corresponding values.
- The test results will be shown numerically on the display or optionally printed on a Printer.

Tear Test for Elastomers and Equivalent Tests

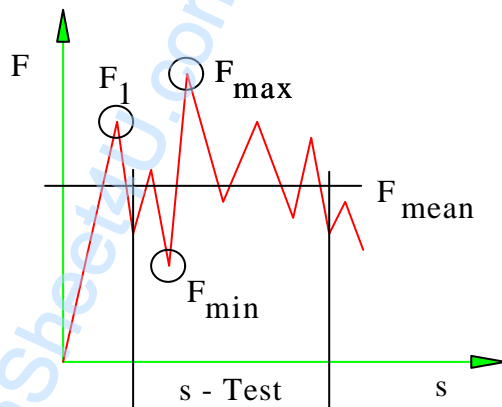

- The specimen will be loaded with constant speed up to break.
- The results are:
- F_1 first load peak
- F_{max} max. load in the area
- F_{min} min load in the area
- F_{mean} mean load in the area
- The test results will be shown numerically on the display or optionally printed on a Printer.

EDC100

Test Description "Hard"

Compression/Tension Test for Metals (according DIN50145)

Determination of Maximum- and Breakload (F_{max} , F_b)

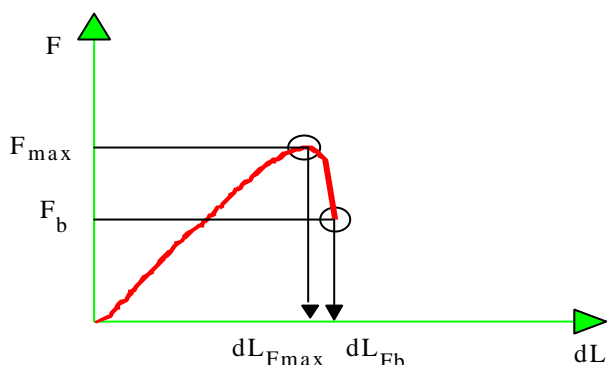

- The specimen will be torn with a constant speed of load increase until break.
- The appearing maximum load (F_{max}), break load (F_b) and the equivalent extensions are the test results.

Offset Yield Stress R_p , R_t

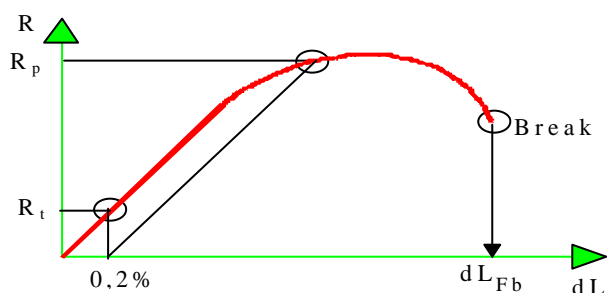

- The specimen will be torn with a constant speed until break.
- The offset yield stress R_t and R_p will be determined by the software as shown. A fault message appears, if the offset yield stress could not be determined.

E-Modulus, Tensile Yield Strength R_{eh} , R_{el}

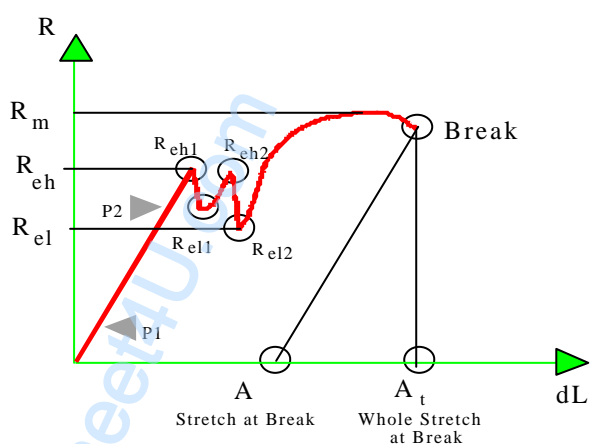

- The specimen will be torn with a constant speed until break.
- The modulus of elasticity as well as the tensile yield strength (R_{eh} , R_{el}) and the stretch at break (A) will be determined.
- By giving the two parameters $P1$ and $P2$, the validity range for the E-modulus gets determined. The E-modulus gets calculated within this range.
- Up to two tensile yield strength (R_{eh1} , R_{eh2} , R_{el1} , R_{el2}) are detected and calculated by the program.

EDC100

External Digital Controller EDC100, Page 14

Test Description “Concrete“:

Pressure Test for Concrete (DIN 1048)

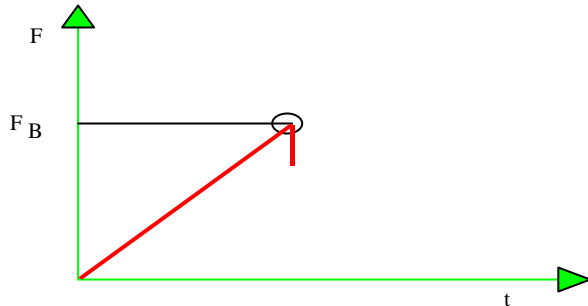

- The specimen will be loaded with a constant speed of compression stress of $0,5 \text{ N/mm}^2/\text{sec}$ (adjustable) up to break.
- The test speed is calculated from the measured side length of the specimen.
- Calculations are the max. load in N and the compression strength in N/mm^2 .
- The test results will be shown numerically on the display or optionally printed on a Printer.

Bending Tensile Test (DIN 1048)

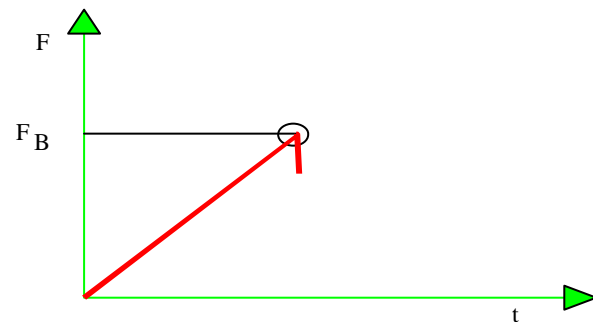

- The specimen will be loaded with a constant speed of bending tensile stress of $0,05 \text{ N/mm}^2/\text{sec}$ (adjustable) up to break.
- The max. load is the bending tensile strength.
- The test results will be shown numerically on the display or optionally printed on a Printer.

Brasilian Test (DIN 1048)

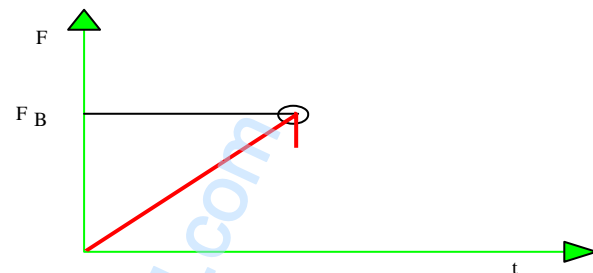

- The specimen will be loaded with a constant speed of compression stress of $0,05 \text{ N/mm}^2/\text{sec}$ (adjustable) up to break.
- The max. load is used to calculate the Brasilian Test result for cylindrical and rectangular specimens.
- The test results will be shown numerically on the display or optionally printed on a Printer.

EDC100

External Digital Controller EDC100, Page 15

Static E-Modulus for Concrete DIN 1048 (MTPC only)

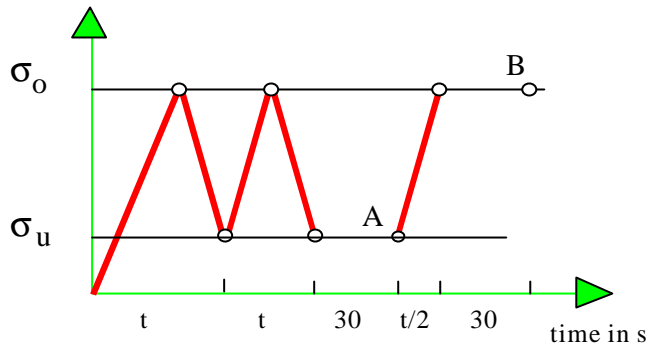

- The specimen will be loaded and unloaded between σ_u and σ_o with a constant speed of compression stress of $0,05 \text{ N/mm}^2/\text{sec}$ (adjustable).
- After the second unload the stress σ_u will be hold constant for 30s and the values σ_u and ϵ_u will be stored (A). Then the specimen will be loaded up to σ_o , stress σ_o will be hold constant for 30s and the values σ_o and ϵ_o will be stored (B). Now, the specimen will be loaded until break.
- The modulus in compression will be calculated from the values A and B.
- The test result can be printed with the MTPC printout record interpreter.

Statistics EDC

During the input of test parameters statistical parameters can be chosen at the EDC. Invalid test results can be cancelled direct after a test, to have valid results in the statistics only. At the end of a series, the statistics get calculated with the function key "N-Series". The statistic values are:

- Minimum value
- Maximum value
- Mean value
- Standard deviation
- Coefficient of variation

Statistical values are available at a printer only.

EDC100

External Digital Controller EDC100, Page 16

PC-Software

EDPC-Programm

EDPC is a universal PC program, able to display, store and print measurement values, test parameters and test results. The testing hardware (e.g. EDC of DOLI; Munich) transfer data via a serial interface to the PC. The data transfer happens in direction to the PC only, i.e. the EDPC program does only "listen". It has no influence on the test course and evaluation.

EDPC is not restricted to definite tests. It works with each test, that transfers its data to the PC, according to the EDPC interface! By that, the EDPC does also fit for tests, which haven't been realised until now (EDPC interface description in chpt. "EDPC INTERFACE").

The EDPC is able to:

- display the test heading,
- store any test parameter into the ASCII log files,
- display measurement values, channel denotations and dimensions of 6 measuring channels, show them in graphics and store them into ASCII measurement value files,
- display test results and store them into ASCII log files,
- print stored log files,
- show stored measurement files in graphics,
- format ASCII files in a manner, that they can be worked on by standard software (e.g. list calculation).

It is very simple to use the EDPC. Of course, it contains on-line helps and the actual function key description.

WIN MTPC Software

For nearly all kind of materials we have special Software. In addition with the Blockprogramm is is possible to drive the instrument in all directions, controls, time delays, etc. etc.

Ask for your application to get the special brochure for your test requirements.

***DOLI OEM Products** are compatible amongst themselves! If you have developed
(or adapted your existing) software to a DOLI electronics system once,
you can connect to a new DOLI product very fast.*

***EDC5, EDC25, EDC100** and the following products. You choose the desired electronics with the exact
resolution and the exact price for the exact application
for your best profit*