

BTRS-5940G / BTRS-5940-SPG / BTRS-5940AG / BTRS-5940A-SPG

1490 nm TX / 1310 nm RX , 3.3V / 155 Mbps **RoHS Compliant Single-Fiber Transceiver**

FEATURES

- I Single Fiber Bi-Directional Transceiver
- I 1490 nm DFB LD Transmitter
- I 1310 nm Receiver
- I Distance Up to 40 km
- I Single +3.3 V Power Supply
- I RoHS Compliant
- I LVPECL Differential Inputs and Outputs
- I 0 to 70°C Operating : BTRS-5940G
- I -20 to 85°C Operating : BTRS-5940AG
- I Wave Solderable and Aqueous Washable
- I Class 1 Laser International Safety Standard IEC-60825 Compliant

APPLICATIONS

- I WDM 622/155 Mb/s Links
- I SONET/SDH Equipment Interconnect
- I Fiber Channel 532 Mb/s Links

DESCRIPTION

The BTRS-5940G series is high performance module for single fiber communications by using 1490 nm transmitter and 1310 nm receiver. The transmitter section uses a multiple quantum well 1490 nm DFB laser and is a class 1 laser compliant according to International Safety Standard IEC-825. The receiver section uses an integrated 1310 nm detector preamplifier (IDP) mounted in an optical header and a limiting post-amplifier IC. A PECL logic interface simplifies interface to external circuitry.

LASER SAFETY

This single mode transceiver is a Class 1 laser product. It complies with IEC 825 and FDA 21 CFR 1040.10 and 1040.11. The transceiver must be operated within the specified temperature and voltage limits. The optical ports of the module shall be terminated with an optical connector or with a dust plug.

ORDER INFORMATION

P/No.	Bit Rate (Mb/s)	Distance (km)	TX (nm)	RX (nm)	Voltage (V)	Package	Temp (°C)	TX Power (dBm)	RX Sens. (dBm)	RoHS Compliant
BTRS-5940G	622	40	1490 DFB	1310	3.3	2X5 SC	0 to 70	0 to -5	-28	Yes
BTRS-5940AG	622	40	1490 DFB	1310	3.3	2X5 SC	-20 to 85	0 to -5	-28	Yes

Note: 1. BTRS-XXXXXX: 2X5 SC receptacle type package. BTRL-XXXXXX: 2X5 LC receptacle type package.

2. BTRX-XXXXXX-APBBB is 2X5 pigtail type package with different connector, A=S is SC connector, A=F is FC connector, A=T is ST connector, A=L is LC connector, A=M is MU connector; BBB is the length of fiber in cm.

Absolute Maximum Ratings					
Parameter	Symbol	Min	Max	Units	Notes
Storage Temperature	Tstg	-40	85	°C	
Operating Temperature	Topr	0	70	°C	BTRS-5940G
		-20	85		BTRS-5940AG
Soldering Temperature	---		260	°C	10 seconds on leads only
Power Supply Voltage	Vcc	0	4.5	V	
Input Voltage	---	GND	Vcc	V	
Output Current	Iout	0	30	mA	

Recommended Operating Conditions					
Parameter	Symbol	Min	Typ	Max	Units / Notes
Power Supply Voltage	Vcc	3.13	3.3	3.47	V
Operating Temperature	Topr	0		70	°C / BTRS-5940G
		-20		85	°C / BTRS-5940AG
Data Rate		50	622	650	Mb/s
Power Supply Current	Icc			260	mA

Transmitter Specifications (0°C < Topr < 70°C, 3.13V < Vcc < 3.47V)						
Parameter	Symbol	Min	Typ	Max	Units	Notes
Optical						
Optical Transmit Power	P _O	-5		0	dBm	1
Output Center Wavelength	λ	1480		1500	nm	
Output Spectrum Width	σ _λ			1	nm	-20 dB Width
Extinction Ratio	E _R	10			dB	
Output Eye	Compliant with Bellcore TR-NWT-000253 and ITU recommendation G.957					
Optical Rise Time	t _r			1.2	ns	10% to 90% Values
Optical Fall Time	t _f			1.2	ns	10% to 90% Values
Relative Intensity Noise	RIN			-116	dB/Hz	
Total Jitter	TJ			0.55	ns	2
Electrical						
Data Input Current – Low	I _{IL}	-350			μA	
Data Input Current – High	I _{IH}			350	μA	
Differential Input Voltage	V _{IH} - V _{IL}	300		1600	mV	
Data Input Voltage – Low	V _{IL} - V _{CC}	-2.0		-1.58	V	3
Data Input Voltage -- High	V _{IH} - V _{CC}	-1.1		-0.74	V	3
Disable Input Voltage -- Low	V _{TDIS,L}	0		0.8	V	TX Output Enabled
Disable Input Voltage -- High	V _{TDIS,H}	V _{CC} - 1.3		V _{CC}	V	TX Output Disabled
Shut Off Time for TxDis	t _{DIS}			1	ms	

- Notes: 1. Output power is power coupled into a 9/125 μm single mode fiber.
 2. Measured with a 2²³-1 PRBS with 72 ones and 72 zeros.
 3. These inputs are compatible with 10K, 10KH and 100K ECL and LVPECL inputs.

Receiver Specifications (0°C < Topr < 70°C, 3.13 V < Vcc < 3.47V)						
Parameter	Symbol	Min	Typ	Max	Units	Notes
Optical						
Sensitivity	---	---	---	-28	dBm	1
Maximum Input Power	P _{in}	-5	---	---	dBm	
Signal Detect -- Asserted	P _a	---	---	-28	dBm	Transition: low to high
Signal Detect -- Deasserted	P _d	-42	---	---	dBm	Transition: high to low
Signal detect -- Hysteresis		1.0	---	4.0	dB	
Wavelength of Operation		1260		1360	nm	2
Optical Return Loss	ORL	14			dB	
Electrical						
Data Output Voltage – Low	V _{OL} - V _{CC}	-2.0		-1.58	V	3
Data Output Voltage – High	V _{OH} - V _{CC}	-1.1		-0.74	V	3
SD Output Voltage -- Low	V _{OL} - V _{CC}	-2.0		-1.58	V	3
SD Output Voltage -- High	V _{OH} - V _{CC}	-1.1		-0.74	V	3
Signal Detect Assert Time	A _S MAX			100	μs	OFF to ON
Signal Detect Deassert Time	A _N S _{MAX}			300	μs	ON to OFF

- Notes: 1. Minimum sensitivity and saturation levels at BER 1E-10 for a 2²³-1 PRBS with 72 ones and 72 zeros.
 2. At least 30 dB optical isolation for the wavelength 1480 to 1580 nm.
 3. These outputs are compatible with 10K, 10KH and 100K ECL and LVPECL outputs.

 CONNECTION DIAGRAM



PIN	Symbol	Notes
1	V_{EEr}	Directly connect this pin to the receiver ground plane
2	V_{CCr}	+3.3V dc power for the receiver section
3	SD	Active high on this indicates a received optical signal.
4	RD-	Receiver Dataout Bar. See recommended circuit schematic
5	RD+	Receiver Dataout. See recommended circuit schematic
6	V_{CCt}	+3.3V dc power for the transmitter section
7	V_{EEt}	Directly connect this plan to the transmitter ground plane
8	TxDis	Transmitter Disable. Connect this pin to +3.3V TTL logic "1" to disable module To enable module connect to TTL logic low "0"
9	TD+	Transmitter Data In. See recommended circuit schematic
10	TD-	Transmitter Data In Bar. See recommended circuit schematic
MS	MS	Mounting Studs. Connect to Chassis Ground

RECOMMENDED CIRCUIT SCHEMATIC

1) Recommended DC Coupled Interface Circuit

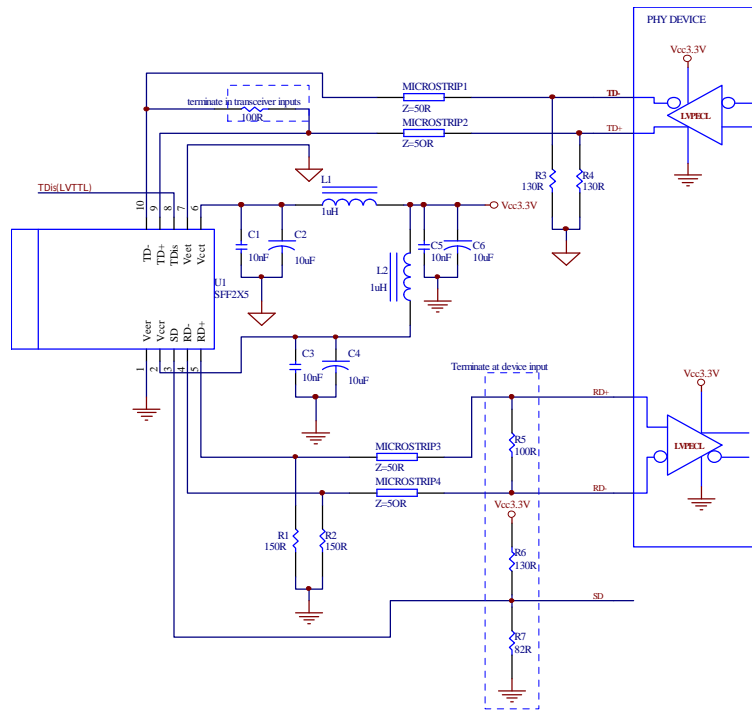

2) Recommended AC Coupled Interface Circuit

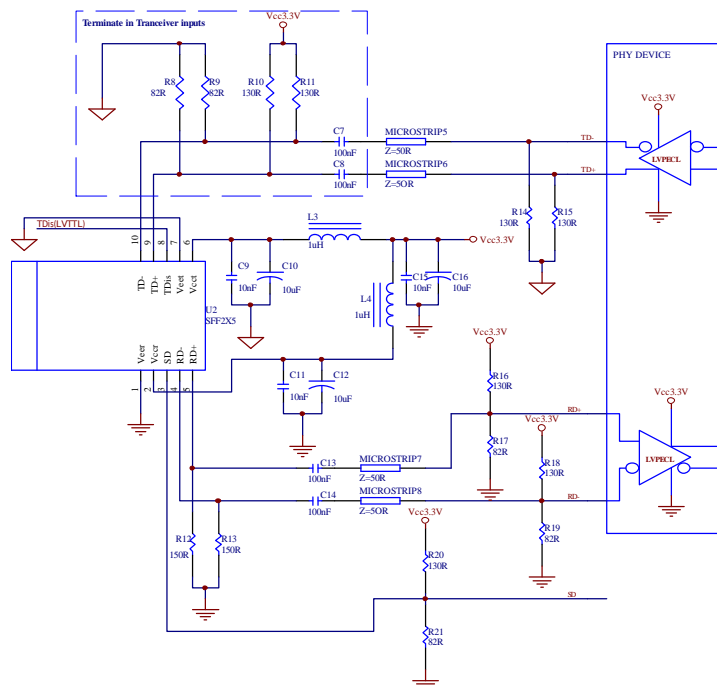

PACKAGE DIAGRAM

Units in mm

1) SC Receptacle

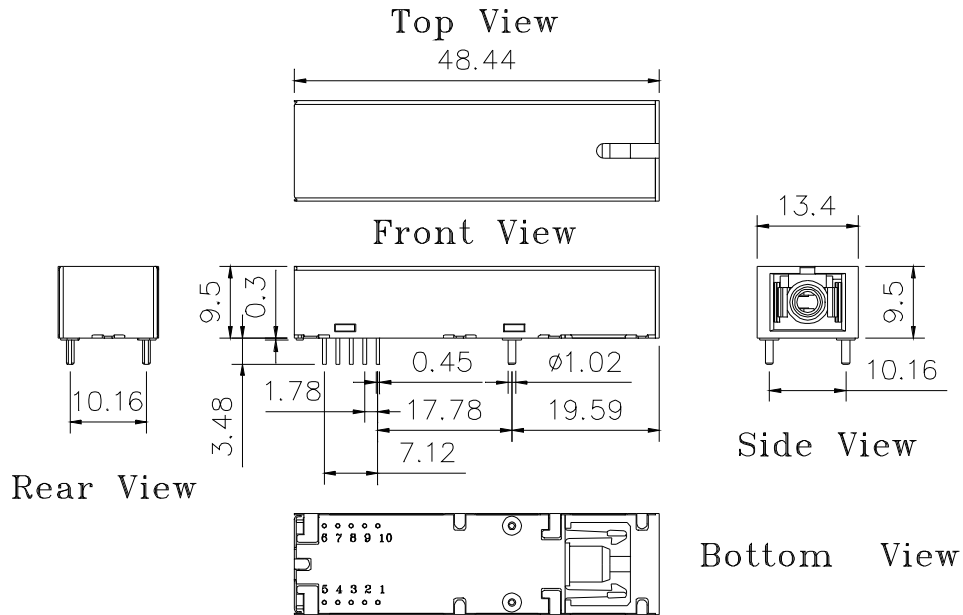

BTRS-5940G / BTRS-5940AG

2) Pigtail

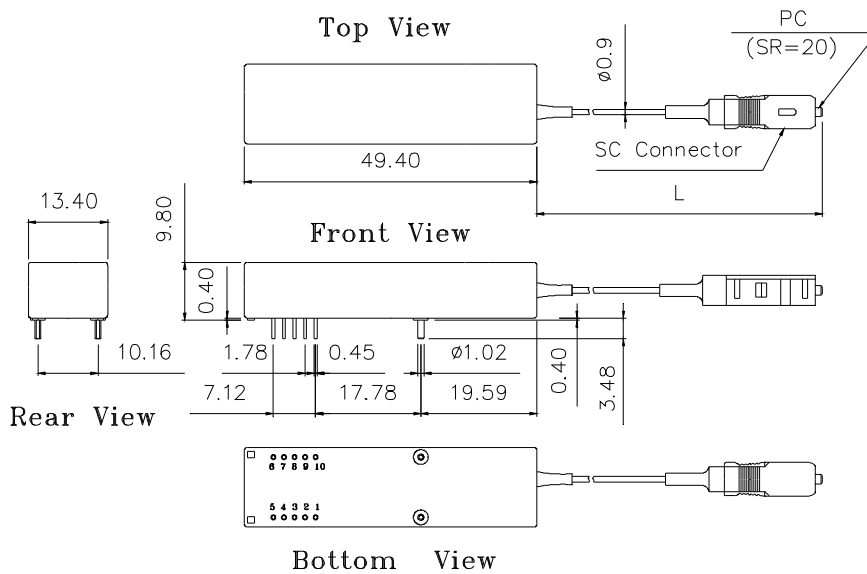

BTRS-5940-SP50G / BTRS-5940A-SP50G

Note: Length L is 50±2 cm. Other pigtail's length is available upon request.

Note: Specifications subject to change without notice.