

Features

- Usable for Automotive 12V/24V and Industrial Applications
- Maximum High-speed Data Transmissions up to 1 Mbaud
- Fully Compatible with ISO 11898
- Controlled Slew Rate
- Standby Mode
- TXD Input Compatible to 3.3V
- Short-circuit Protection
- Overtemperature Protection
- High Voltage Bus Lines Protection, $-40V$ to $+40V$
- High Speed Differential Receiver Stage with a Wide Common Mode Range, $-10V$ to $+10V$, for High Electromagnetic Immunity (EMI)
- Fully Controlled Bus Lines, CANH and CANL to Minimize Electromagnetic Emissions (EME)
- High ESD Protection at CANH, CANL HBM 8 kV, MM 300V

1. Description

The ATA6660 is a monolithic circuit based on the Atmel's Smart Power BCD60-III technology. It is especially designed for high speed CAN-Controller (CAN-C) differential mode data transmission between CAN-Controllers and the physical differential bus lines.

Figure 1-1. Block Diagram

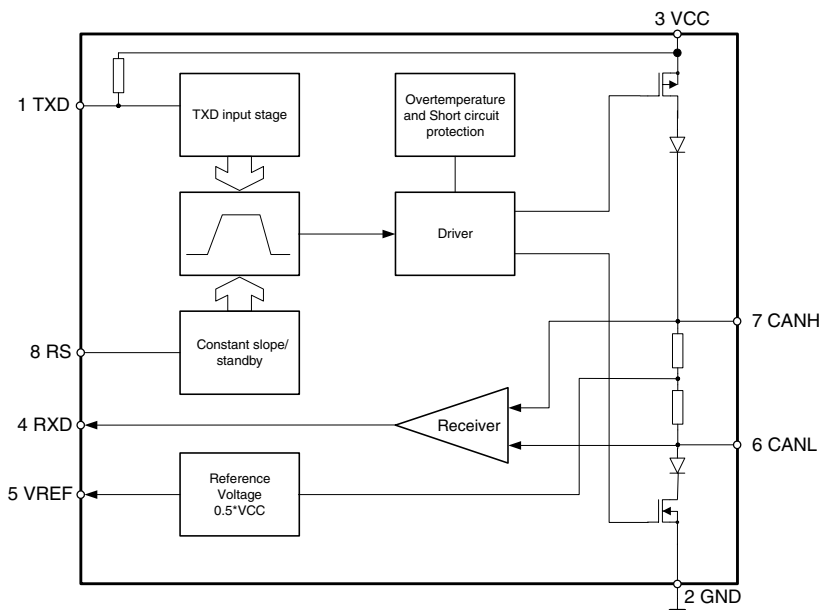

High-speed Can Transceiver

ATA6660





2. Pin Configuration

Figure 2-1. Pinning SO8

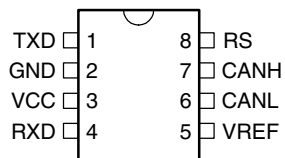

Table 2-1. Pin Description

Pin	Symbol	Function
1	TXD	Transmit data input
2	GND	Ground
3	VCC	Supply voltage
4	RXD	Receive data output
5	VREF	Reference voltage output
6	CANL	Low level CAN voltage input/output
7	CANH	High level CAN voltage input/output
8	RS	Switch standby mode/normal mode

3. Functional Description

The ATA6660 is a monolithic circuit based on Atmel's Smart Power BCD60-III technology. It is especially designed for high-speed differential mode data transmission in harsh environments like automotive and industrial applications. Baudrate can be adjusted up to 1 Mbaud. The ATA6660 is fully compatible to the ISO11898, the developed standard for high speed CAN-C (Controller Area Network) communication.

3.1 Voltage Protection and ESD

High voltage protection circuitry on both line pins, CANH (pin 7) and CANL (pin 6), allow bus line voltages in the range of -40V to $+40\text{V}$. ESD protection circuitry on line pins allow HBM = 8 kV, MM = 300V. The implemented high voltage protection on bus line output/input pins (7/6) makes the ATA6660 suitable for 12V automotive applications as well as 24V automotive applications.

3.2 Slope Control

A fixed slope is adjusted to prevent unsymmetrical transients on bus lines causing EMC problems. Controlled bus lines, both CANH and CANL signal, will reduce radio frequency interference to a minimum. In well designed bus configurations the filter design costs can be reduced dramatically.

3.3 Overcurrent Protection

In the case of a line shorts, like CANH to GND, CANL to VCC, integrated short current limitation allows a maximum current of $I_{\text{CANH_SC}}$ or $I_{\text{CANL_SC}}$. If junction temperature rises above 165°C an internal overtemperature protection circuitry shuts down both output stages, the receiver will stay activated.

3.4 Standby Mode

The ATA6660 can be switched to standby mode by forcing the voltage $V_{\text{RS}} > 0.87 \times V_{\text{CC}}$. In standby mode the supply current will reduce dramatically, supply current during standby mode is typical $600 \mu\text{A}$ ($I_{\text{VCC_stby}}$). Transmitting data function will not be supported, but the opportunity will remain to receive data. A high-speed comparator is listening for activities on the bus. A dominant bus signal will force the output RXD to a low level in typical $t_{\text{dRXDL}} = 400 \text{ ns}$. If the RS pin is not connected, causing through a broken connection to the controller, the ATA6660 will switch to standby mode automatically.

3.5 High-speed Receiver

In normal mode a fast receiver circuitry combined with a resistor network is able to detect differential bus line voltages $V_{\text{rec_th}} > 0.9\text{V}$ as dominant bit, differential bus line voltages $V_{\text{rec_th}} < 0.5\text{V}$ as recessive bit.

The wide receiver common mode range, -10V to $+10\text{V}$, combined with a symmetrical differential receiver stage offers high immunity against electromagnetic interference. A typical hysteresis of 70 mV is implemented. Dominant differential bus voltages forces RXD output (pin 4) to low level, recessive differential bus voltages to high level.

3.6 TXD Input

The input stage pin 1 (TXD) is compatible for 3.3V output levels from new controller families. Pull-up resistance (25 k Ω) forces the IC to recessive mode, if TXD-Pin is not connected. TXD low signal drives the transmitter into dominant state.

3.7 Transmitter

A integrated complex compensation technique allows stable data transmission up to 1 MBaud. Low level on TXD input forces bus line voltages CANH to 3.5V, CANL to 1.5V with a termination resistor of 60 Ω . In the case of a line short circuit, like CANH to GND, CANL to VCC, integrated short current limitation circuitry allows a maximum current of 150 mA. If junction temperature rises above typical 163 $^{\circ}$ C an internal overtemperature protection shuts down both output stages, the receive mode will stay activated.

3.8 Split Termination Concept

With a modified bus termination (see [Figure 8-3 on page 10](#)) a reduction of emission and a higher immunity of the bus system can be achieved. The one 120 Ω resistor at the bus line end nodes is split into two resistors of equal value, i.e., two resistors of 60 Ω . The resistors for the stub nodes is recommended with two resistors of 1.3 k Ω (for example 8 stub nodes and 2 bus end nodes) Notice: The bus load of all the termination resistors has to stay within the range of 50 Ω to 65 Ω .

The common mode signal at the centre tap of the termination is connected to ground via a capacitor of e.g., $C_{\text{split}} = 10 \text{ nF}$ to 100 nF. A separate ground lead to the ground pin of the module connector is recommended.

4. Absolute Maximum Ratings

Stresses beyond those listed under “Absolute Maximum Ratings” may cause permanent damage to the device. This is a stress rating only and functional operation of the device at these or any other conditions beyond those indicated in the operational sections of this specification is not implied. Exposure to absolute maximum rating conditions for extended periods may affect device reliability.

Parameters	Symbol	Conditions	Min.	Max.	Unit
Supply voltage	V_{CC}		-0.3	+6	V
DC voltage at pins 1, 4, 5 and 8	$V_{TXD}, V_{REP}, V_{RS}, V_{RXD}$		-0.3	$V_{CC} + 0.3$	V
DC voltage at pins 6 and 7	V_{CANH}, V_{CANL}	$0V < V_{CC} < 5.25V$; no time limit	-40.0	+40.0	V
Transient voltage at pins 6 and 7			-150	+100	V
Storage temperature	T_{Stg}		-55	+150	°C
Operating ambient temperature	T_{amb}		-40	+125	°C
ESD classification	All pins	HBM ESD S.5.1 MM JEDEC A115A	± 3000 ± 200		V V
ESD classification	Pin 6, 7 versus pin 2	HBM 1.5 k Ω , 100 pF MM 0 Ω , 200 pF	± 8000 ± 300		V V

5. Thermal Resistance

Parameters	Symbol	Value	Unit
Thermal resistance from junction to ambient	R_{thJA}	160	K/W

6. Truth Table

VCC	TXD	RS	CANH	CANL	Bus State	RXD
4.75V to 5.25V	0	$< 0.3 \times V_{CC}$	3.5V	1.5V	Dominant	0
4.75V to 5.25V	1 (or floating)	$< 0.3 \times V_{CC}$	$0.5 \times V_{CC}$	$0.5 \times V_{CC}$	Recessive	1
4.75V to 5.25V	X	$> 0.87 \times V_{CC}$	$0.5 \times V_{CC}$	$0.5 \times V_{CC}$	Recessive	1

7. RS (Pin 8) Functionality

Slope Control	Mode	Voltage and Current Levels
$V_{RS} > 0.87 \times V_{CC}$	Standby	$I_{RS} < 10 \mu A $
$V_{RS} < 0.3 \times V_{CC}$	Constant slope control	$I_{RS} \leq 500 \mu A$



8. Electrical Characteristics

$V_{CC} = 4.75V$ to $5.25V$; $T_{amb} = -40^{\circ}C$ to $+125^{\circ}C$; $R_{Bus} = 60\Omega$, unless otherwise specified.
All voltages referenced to ground (pin 2); positive input current.

No.	Parameters	Test Conditions	Pin	Symbol	Min.	Typ.	Max.	Unit	Type*
1	Supply Current								
1.1	Supply current dominant	$V_{TXD} = 0V$ $V_{RS} = 0V$	3	I_{VCC_dom}		45	60	mA	A
1.2	Supply current recessive	$V_{TXD} = 5V$ $V_{RS} = 0V$	3	I_{VCC_rec}		10	15	mA	A
1.3	Supply current stand-by	$V_{RS} = 5V$	3	I_{VCC_stby}		600	980	μA	A
2	Transmitter Data Input TXD								
2.1	HIGH level input voltage	$V_{TXD} = 5V$ $V_{RS} = 0V$	1	V_{TXDH}	2		$V_{CC} + 0.3$	V	A
2.2	LOW level input voltage	$V_{TXD} = 0V$ $V_{RS} = 0V$	1	V_{TXDL}	-0.3		+1	V	A
2.3	HIGH level input current	$V_{TXD} = V_{CC}$	1	I_{IH}	-1		0	μA	A
2.4	LOW level input voltage	$V_{TXD} = 0V$	1	I_{IL}	-500		-50	μA	A
3	Receiver Data Output RXD								
3.1	High level output voltage	$I_{RXD} = -100 \mu A$	4	V_{RXDH}	$0.8 \times V_{CC}$		V_{CC}	V	A
3.2	Low level output voltage	$I_{RXD} = 1 \text{ mA}$	4	V_{RXDL}	0		$0.2 \times V_{CC}$	V	A
3.3	Short current at RXD	$V_{TXD} = 5V$ $V_{RXD} = 0V$	4	I_{RXDs1}	-3		-1	mA	A
3.4	Short current at RXD	$V_{TXD} = 0V$ $V_{RXD} = 5V$	4	I_{RXDs2}	2		6	mA	A
4	Reference Output Voltage VREF								
4.1	Reference output voltage normal mode	$V_{RS} = 0V$; $-50 \mu A < I_5 < 50 \mu A$	5	V_{ref_no}	$0.45 V_{CC}$		$0.55 V_{CC}$	V	A
4.2	Reference output voltage standby mode	$V_{RS} = 5V$; $-5 \mu A < I_5 < 5 \mu A$	5	V_{ref_stby}	$0.4 \times V_{CC}$		$0.6 V_{CC}$	V	A
5	DC Bus Transmitter CANH; CANL								
5.1	Recessive bus voltage	$V_{TXD} = V_{CC}$; no load	6, 7	V_{CANH} ; V_{CANL}	2.0	2.5	3.0	V	A
5.2	$I_{O(CANH)(reces)}$ $I_{O(CANL)(reces)}$	$-40V < V_{CANH}$; $V_{CANL} < 40V$; $0V < V_{CC} < 5.25V$	6, 7	I_{O_reces}	-5		+5	mA	A
5.3	CANH output voltage dominant	$V_{TXD} = 0V$	6, 7	V_{CANH}	2.8	3.5	4.5	V	A
5.4	CANL output voltage dominant	$V_{TXD} = 0V$	6, 7	V_{CANL}	0.5	1.5	2.0	V	A

*) Type means: A = 100% tested, B = 100% correlation tested, C = Characterized on samples, D = Design parameter

8. Electrical Characteristics (Continued)

$V_{CC} = 4.75V$ to $5.25V$; $T_{amb} = -40^{\circ}C$ to $+125^{\circ}C$; $R_{Bus} = 60\Omega$, unless otherwise specified.

All voltages referenced to ground (pin 2); positive input current.

No.	Parameters	Test Conditions	Pin	Symbol	Min.	Typ.	Max.	Unit	Type*
5.5	Differential bus output voltage ($V_{CANH} - V_{CANL}$)	$V_{TXD} = 0V$; $R_L = 45\Omega$ to 60Ω ; $V_{CC} = 4.9V$	6, 7	V_{diff_dom}	1.5	2	3.0	V	A
5.6		$V_{TXD} = V_{CC}$; no load	6, 7	V_{diff_rec}	-500		+50	mV	A
5.7	Short-circuit CANH current	$V_{CANH} = -10V$ $TXD = 0V$	6, 7	I_{CANH_SC}	-35		-100	mA	A
5.8	Short-circuit CANL current	$V_{CANL} = 18V$ $TXD = 0V$	6, 7	I_{CANL_SC}	50	-	150	mA	A
6	DC Bus Receiver CANH; CANL								
6.1	Differential receiver threshold voltage normal mode	$-10V < V_{CANH} < +10V$ $-10V < V_{CANL} < +10V$	6, 7	V_{rec_th}	0.5	0.7	0.9	V	A
6.2	Differential receiver threshold voltage stand-by mode	$V_{RS} = V_{CC}$	6, 7	$V_{rec_th_stby}$	0.5	0.7	0.9	V	A
6.3	Differential input hysteresis		6, 7	$V_{diff(hys)}$		70		mV	A
6.4	CANH and CANL common mode input resistance		6, 7	R_i	5	15	25	k Ω	A
6.5	Differential input resistance		6, 7	R_{diff}	10	30	100	k Ω	A
6.6	Matching between CANH and CANL common mode input resistance		6, 7	R_{i_m}	-3		+3	%	A
6.7	CANH, CANL input capacitance		6, 7	C_i			20	pF	D
6.8	Differential input capacitance		6, 7	C_{diff}			10	pF	D
6.9	CANH, CANL input leakage input current	$V_{CC} = 0V$ $V_{CANH} = 3.5V$ $V_{CANL} = 1.5V$	6, 7	$I_{LI(CANH)}$; $I_{LI(CANL)}$			250	μA	A
7	Thermal Shut-down								
7.1	Shut-down junction temperature for CANH/CANL			$T_{J(SD)}$	150	163	175	$^{\circ}C$	B
7.2	Switch on junction temperature for CANH/CANL			$T_{J(SD)}$	140	154	165	$^{\circ}C$	B
7.3	Temperature hysteresis			T_{Hys}		10		K	B

*) Type means: A = 100% tested, B = 100% correlation tested, C = Characterized on samples, D = Design parameter



8. Electrical Characteristics (Continued)

$V_{CC} = 4.75V$ to $5.25V$; $T_{amb} = -40^{\circ}C$ to $+125^{\circ}C$; $R_{Bus} = 60\Omega$, unless otherwise specified.
All voltages referenced to ground (pin 2); positive input current.

No.	Parameters	Test Conditions	Pin	Symbol	Min.	Typ.	Max.	Unit	Type*
8	Timing Characteristics Normal Mode, $V_{RS} \leq 0.3 \times V_{CC}$ (see Figure 8-1 on page 9)								
8.1	Delay TXD to bus active	$V_{RS} = 0V$		$t_{d(TXD-BUS_ON)}$		120	180	ns	A
8.2	Delay TXD to bus inactive	$V_{RS} = 0V$		$t_{d(TXD-BUS_OFF)}$		50	100	ns	A
8.3	Delay TXD to RXD, recessive to dominant	$V_{RS} = 0V$	6, 7	$t_{d_activ(TXD-RXD)}$		200	420	ns	A
8.4	Delay TXD to RXD, dominant to recessive	$V_{RS} = 0V$		$t_{d_inactiv(TXD-RXD)}$		180	460	ns	A
8.5	Difference between Delay TXD to RXD dominant to Delay recessive	$t_{diff} = t_{d_activ(TXD-RXD)} - t_{d_inactiv(TXD-RXD)}$		t_{diff}	-280		80	ns	A
9	Timing Characteristics Stand-by Mode $V_{RS} \geq 0.87 \times V_{CC}$								
9.1	Bus dominant to RXD low in stand-by mode	$V_{RS} = V_{CC}$	4	t_{dRxDL}		300	450	ns	A
9.2	Wake up time after stand-by mode (time delay between stand-by to normal mode and to bus dominant)	TXD = 0V V_{RS} from 0V to V_{CC}	6, 7	T_{wake_up}			2	μs	A
10	Standby/Normal Mode Selectable via RS (Pin 8)								
10.1	Input voltage for normal mode	$V_{RS} = V_{CC}$	8	V_{RS}			$0.3 \times V_{CC}$	V	A
10.2	Input current for normal mode	$V_{RS} = 0V$	8	I_{RS}	-700			μA	A
10.3	Input voltage for stand-by mode		8	V_{stby}	$0.87 \times V_{CC}$			V	A

*) Type means: A = 100% tested, B = 100% correlation tested, C = Characterized on samples, D = Design parameter

Figure 8-1. Timing Diagrams

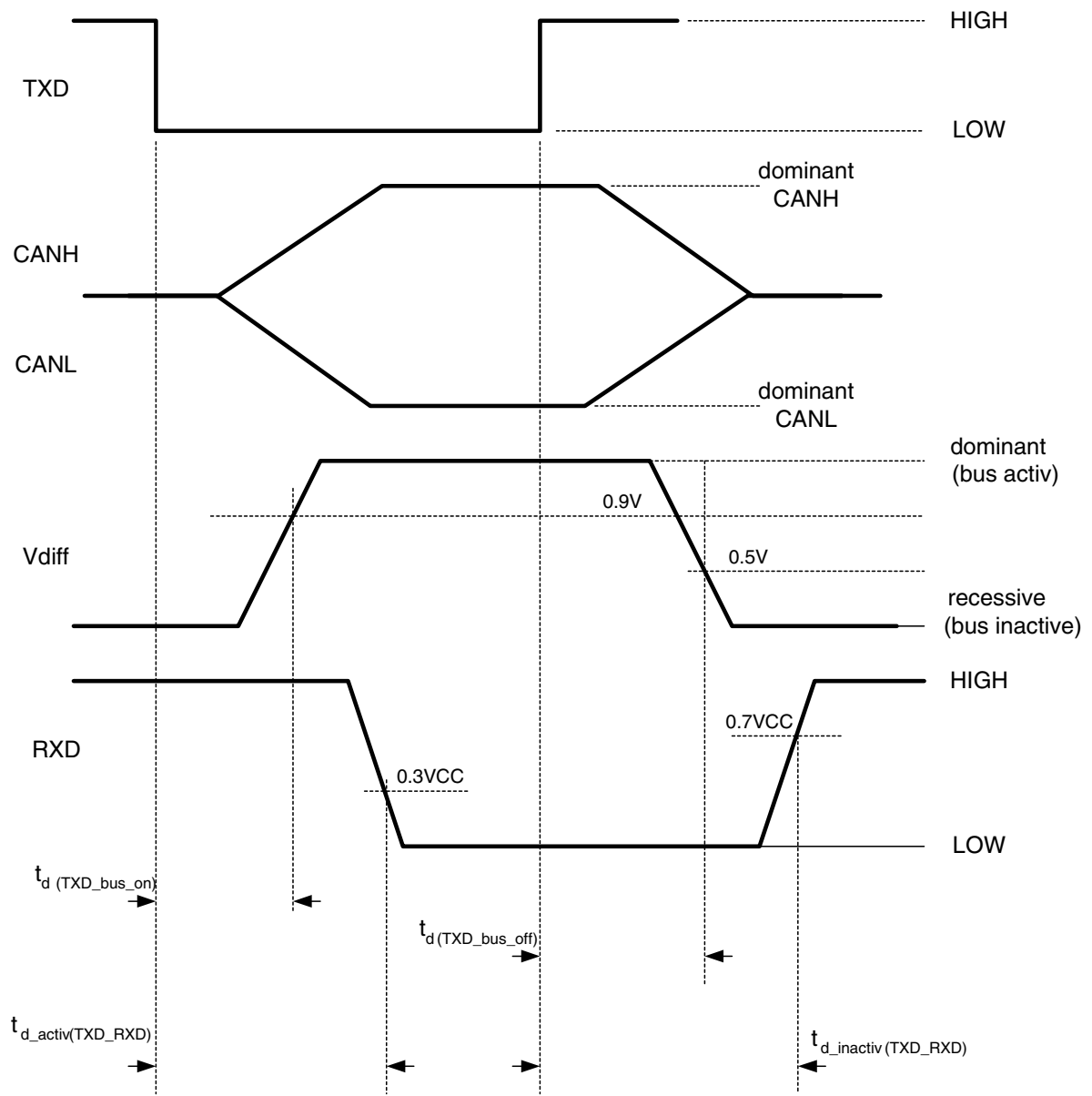

Figure 8-2. Test Circuit for Timing Characteristics

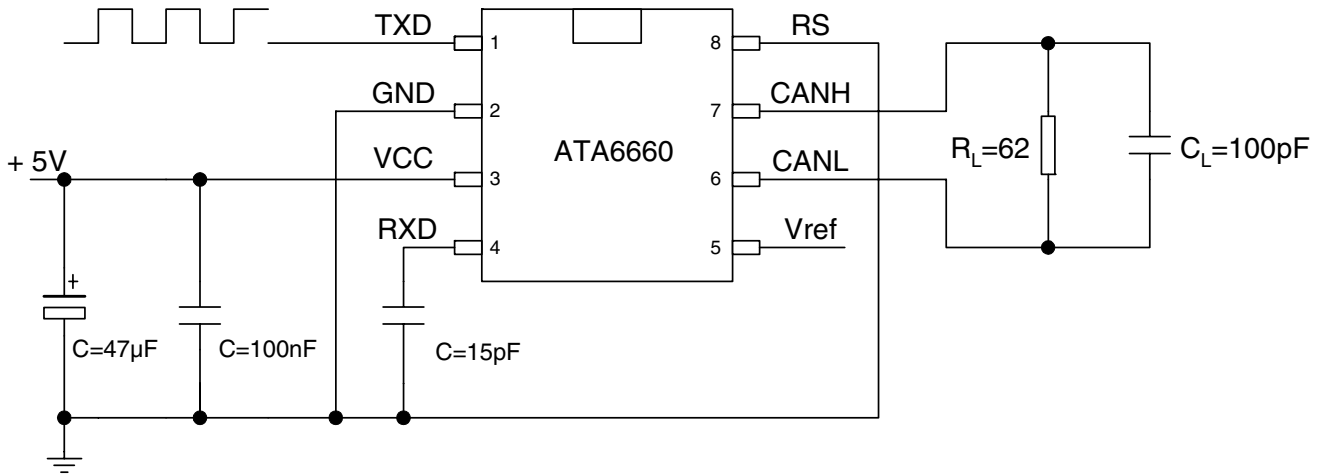
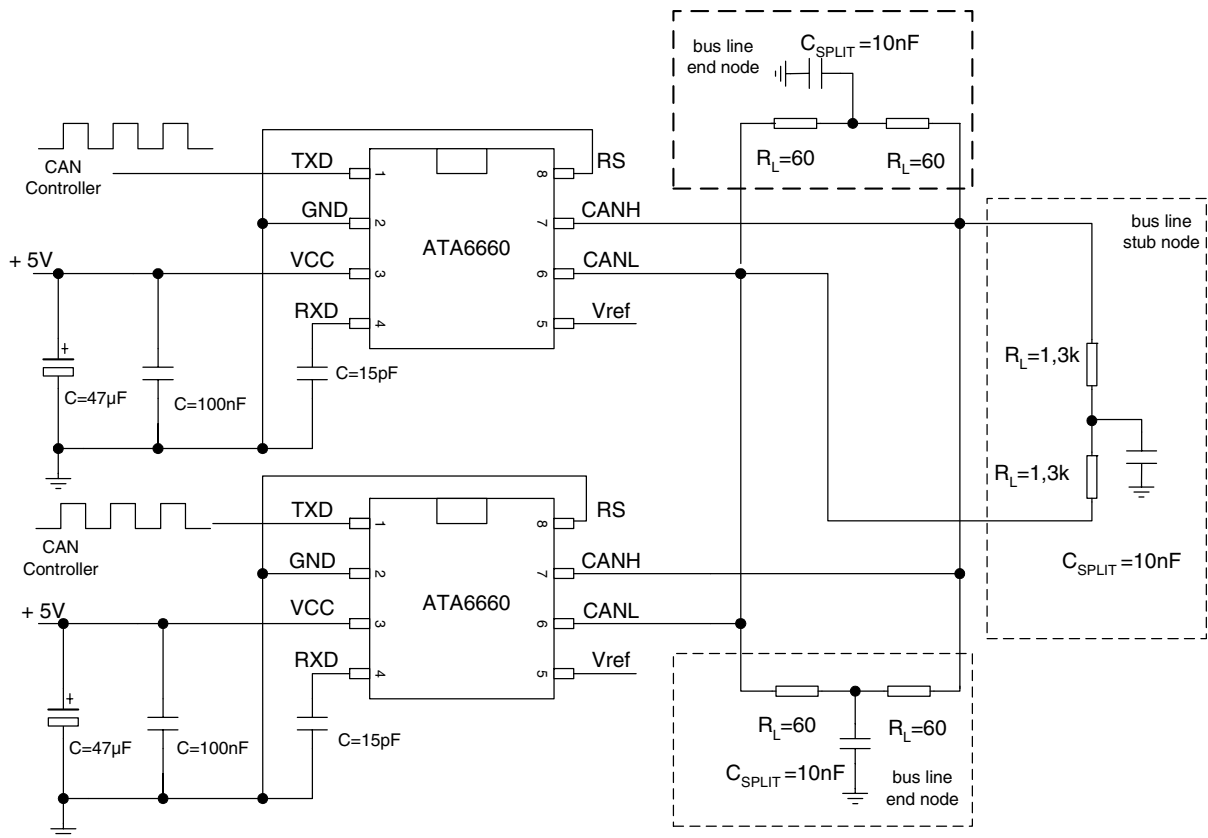

Figure 8-3. Bus Application with Split Termination Concept



9. Ordering Information

Extended Type Number	Package	Remarks
ATA6660-TAPY	SO8	Taped and reeled, Pb-free
ATA6660-TAQY	SO8	Taped and reeled, Pb-free

10. Package Information

Package SO8

Dimensions in mm

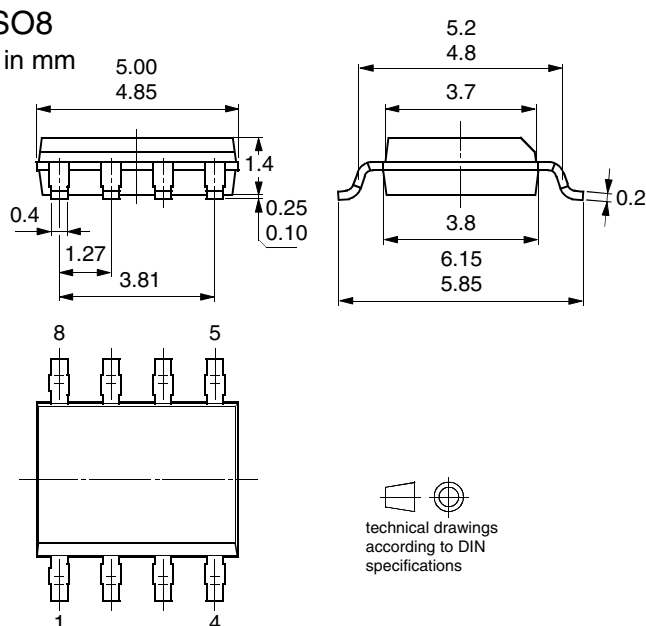

11. Revision History

Please note that the following page numbers referred to in this section refer to the specific revision mentioned, not to this document.

Revision No.	History
4582D-BCD-06/06	<ul style="list-style-type: none"> Put datasheet in a new template Pb-free logo on page 1 deleted Table "Ordering Information" on page 11 changed
4582C-BCD-09/05	<ul style="list-style-type: none"> Put datasheet in a new template Pb-free logo on page 1 added Heading rows on Table "Absolute Maximum Ratings" on page 5 added Table "Ordering Information" on page 11 changed



Atmel Corporation

2325 Orchard Parkway
San Jose, CA 95131, USA
Tel: 1(408) 441-0311
Fax: 1(408) 487-2600

Regional Headquarters

Europe

Atmel Sarl
Route des Arsenaux 41
Case Postale 80
CH-1705 Fribourg
Switzerland
Tel: (41) 26-426-5555
Fax: (41) 26-426-5500

Asia

Room 1219
Chinachem Golden Plaza
77 Mody Road Tsimshatsui
East Kowloon
Hong Kong
Tel: (852) 2721-9778
Fax: (852) 2722-1369

Japan

9F, Tonetsu Shinkawa Bldg.
1-24-8 Shinkawa
Chuo-ku, Tokyo 104-0033
Japan
Tel: (81) 3-3523-3551
Fax: (81) 3-3523-7581

Atmel Operations

Memory

2325 Orchard Parkway
San Jose, CA 95131, USA
Tel: 1(408) 441-0311
Fax: 1(408) 436-4314

Microcontrollers

2325 Orchard Parkway
San Jose, CA 95131, USA
Tel: 1(408) 441-0311
Fax: 1(408) 436-4314

La Chantrerie
BP 70602
44306 Nantes Cedex 3, France
Tel: (33) 2-40-18-18-18
Fax: (33) 2-40-18-19-60

ASIC/ASSP/Smart Cards

Zone Industrielle
13106 Rousset Cedex, France
Tel: (33) 4-42-53-60-00
Fax: (33) 4-42-53-60-01

1150 East Cheyenne Mtn. Blvd.
Colorado Springs, CO 80906, USA
Tel: 1(719) 576-3300
Fax: 1(719) 540-1759

Scottish Enterprise Technology Park
Maxwell Building
East Kilbride G75 0QR, Scotland
Tel: (44) 1355-803-000
Fax: (44) 1355-242-743

RF/Automotive

Theresienstrasse 2
Postfach 3535
74025 Heilbronn, Germany
Tel: (49) 71-31-67-0
Fax: (49) 71-31-67-2340

1150 East Cheyenne Mtn. Blvd.
Colorado Springs, CO 80906, USA
Tel: 1(719) 576-3300
Fax: 1(719) 540-1759

Biometrics/Imaging/Hi-Rel MPU/ High-Speed Converters/RF Datacom

Avenue de Rochepleine
BP 123
38521 Saint-Egreve Cedex, France
Tel: (33) 4-76-58-30-00
Fax: (33) 4-76-58-34-80

Literature Requests

www.atmel.com/literature

Disclaimer: The information in this document is provided in connection with Atmel products. No license, express or implied, by estoppel or otherwise, to any intellectual property right is granted by this document or in connection with the sale of Atmel products. **EXCEPT AS SET FORTH IN ATMEL'S TERMS AND CONDITIONS OF SALE LOCATED ON ATMEL'S WEB SITE, ATMEL ASSUMES NO LIABILITY WHATSOEVER AND DISCLAIMS ANY EXPRESS, IMPLIED OR STATUTORY WARRANTY RELATING TO ITS PRODUCTS INCLUDING, BUT NOT LIMITED TO, THE IMPLIED WARRANTY OF MERCHANTABILITY, FITNESS FOR A PARTICULAR PURPOSE, OR NON-INFRINGEMENT. IN NO EVENT SHALL ATMEL BE LIABLE FOR ANY DIRECT, INDIRECT, CONSEQUENTIAL, PUNITIVE, SPECIAL OR INCIDENTAL DAMAGES (INCLUDING, WITHOUT LIMITATION, DAMAGES FOR LOSS OF PROFITS, BUSINESS INTERRUPTION, OR LOSS OF INFORMATION) ARISING OUT OF THE USE OR INABILITY TO USE THIS DOCUMENT, EVEN IF ATMEL HAS BEEN ADVISED OF THE POSSIBILITY OF SUCH DAMAGES.** Atmel makes no representations or warranties with respect to the accuracy or completeness of the contents of this document and reserves the right to make changes to specifications and product descriptions at any time without notice. Atmel does not make any commitment to update the information contained herein. Unless specifically provided otherwise, Atmel products are not suitable for, and shall not be used in, automotive applications. Atmel's products are not intended, authorized, or warranted for use as components in applications intended to support or sustain life.

© 2006 Atmel Corporation. All rights reserved. Atmel®, logo and combinations thereof, Everywhere You Are® and others are registered trademarks or trademarks of Atmel Corporation or its subsidiaries. Other terms and product names may be trademarks of others.