



# Intel® PXA27x Processor Family

## Electrical, Mechanical, and Thermal Specification

---

### Data Sheet

- High-performance processor:
  - Intel XScale® microarchitecture with Intel® Wireless MMX™ Technology
  - 7 Stage pipeline
  - 32 KB instruction cache
  - 32 KB data cache
  - 2 KB “mini” data cache
  - Extensive data buffering
- 256 Kbytes of internal SRAM for high speed code or data storage preserved during low-power states
- High-speed baseband processor interface (Mobile Scalable Link)
- Rich serial peripheral set:
  - AC'97 audio port
  - I<sup>2</sup>S audio port
  - USB Client controller
  - USB Host controller
  - USB On-The-Go controller
  - Three high-speed UARTs (two with hardware flow control)
  - FIR and SIR infrared communications port
- Hardware debug features — IEEE JTAG interface with boundary scan
- Hardware performance-monitoring features with on-chip trace buffer
- Real-time clock
- Operating-system timers
- LCD Controller
- Universal Subscriber Identity Module interface
- Low power:
  - Wireless Intel Speedstep® Technology
  - Less than 500 mW typical internal dissipation
  - Supply voltage may be reduced to 0.85 V
  - Four low-power modes
  - Dynamic voltage and frequency management
- High-performance memory controller:
  - Four banks of SDRAM: up to 104 MHz @ 1.8 V I/O interface
  - Six static chip selects
  - Support for PCMCIA and Compact Flash
  - Companion chip interface
- Flexible clocking:
  - CPU clock from 104 to 520 MHz
  - Flexible memory clock ratios
  - Frequency changes
  - Functional clock gating
- Additional peripherals for system connectivity:
  - SD Card / MMC Controller (with SPI mode support)
  - Memory Stick card controller
  - Three SSP controllers
  - Two I<sup>2</sup>C controllers
  - Four pulse-width modulators (PWMs)
  - Keypad interface with both direct and matrix keys support
  - Most peripheral pins double as GPIOs



INFORMATION IN THIS DOCUMENT IS PROVIDED IN CONNECTION WITH INTEL® PRODUCTS. NO LICENSE, EXPRESS OR IMPLIED, BY ESTOPPEL OR OTHERWISE, TO ANY INTELLECTUAL PROPERTY RIGHTS IS GRANTED BY THIS DOCUMENT. EXCEPT AS PROVIDED IN INTEL'S TERMS AND CONDITIONS OF SALE FOR SUCH PRODUCTS, INTEL ASSUMES NO LIABILITY WHATSOEVER, AND INTEL DISCLAIMS ANY EXPRESS OR IMPLIED WARRANTY, RELATING TO SALE AND/OR USE OF INTEL PRODUCTS INCLUDING LIABILITY OR WARRANTIES RELATING TO FITNESS FOR A PARTICULAR PURPOSE, MERCHANTABILITY, OR INFRINGEMENT OF ANY PATENT, COPYRIGHT OR OTHER INTELLECTUAL PROPERTY RIGHT. Intel products are not intended for use in medical, life saving, life sustaining applications.

Intel may make changes to specifications and product descriptions at any time, without notice.

Designers must not rely on the absence or characteristics of any features or instructions marked "reserved" or "undefined". Intel reserves these for future definition and shall have no responsibility whatsoever for conflicts or incompatibilities arising from future changes to them. The PXA27x processor may contain design defects or errors known as errata which may cause the product to deviate from published specifications. Current characterized errata are available on request.

This document and the software described in it are furnished under license and may only be used or copied in accordance with the terms of the license. The information in this document is furnished for informational use only, is subject to change without notice, and should not be construed as a commitment by Intel Corporation. Intel Corporation assumes no responsibility or liability for any errors or inaccuracies that may appear in this document or any software that may be provided in association with this document. Except as permitted by such license, no part of this document may be reproduced, stored in a retrieval system, or transmitted in any form or by any means without the express written consent of Intel Corporation.

Contact your local Intel sales office or your distributor to obtain the latest specifications and before placing your product order.

Copies of documents which have an ordering number and are referenced in this document, or other Intel literature may be obtained by calling 1-800-548-4725 or by visiting Intel's website at <http://www.intel.com>.

AlertVIEW, AnyPoint, AppChoice, BoardWatch, BunnyPeople, CablePort, Celeron, Chips, CT Connect, CT Media, Dialogic, DM3, EtherExpress, ETOX, FlashFile, i386, i486, i960, iCOMP, InstantIP, Intel, Intel logo, Intel386, Intel486, Intel740, IntelDX2, IntelDX4, IntelSX2, Intel Create & Share, Intel GigaBlade, Intel InBusiness, Intel Inside, Intel Inside logo, Intel NetBurst, Intel NetMerge, Intel NetStructure, Intel Play, Intel Play logo, Intel SingleDriver, Intel SpeedStep, Intel StrataFlash, Intel TeamStation, Intel Xeon, Intel XScale, IPLink, Itanium, LANDesk, LanRover, MCS, MMX, MMX logo, Optimizer logo, OverDrive, Paragon, PC Dads, PC Parents, PDCharm, Pentium, Pentium II Xeon, Pentium III Xeon, Performance at Your Command, RemoteExpress, Shiva, SmartDie, Solutions960, Sound Mark, StorageExpress, The Computer Inside., The Journey Inside, TokenExpress, Trillium, VoiceBrick, Vtune, and Xircom are trademarks or registered trademarks of Intel Corporation or its subsidiaries in the United States and other countries.

\*Other names and brands may be claimed as the property of others.

Copyright © Intel Corporation, 2004

# Contents

---

<b>1</b>	<b>Introduction</b> .....	1-1
1.1	About This Document .....	1-1
1.1.1	Number Representation .....	1-1
1.1.2	Typographical Conventions .....	1-1
1.1.3	Applicable Documents .....	1-2
<b>2</b>	<b>Functional Overview</b> .....	2-1
<b>3</b>	<b>Package Information</b> .....	3-1
3.1	Package Information .....	3-1
3.2	Processor Materials .....	3-2
3.3	Junction To Case Temperature Thermal Resistance .....	3-3
3.4	Processor Markings .....	3-3
3.5	Intel® PXA27x Processor Family Identification Markings .....	3-5
3.6	Tray Drawing .....	3-5
<b>4</b>	<b>Pin Listing and Signal Definitions</b> .....	4-1
4.1	Ball Map View .....	4-2
4.1.1	1.8V SCSP Ball Map .....	4-2
4.2	Intel® PXA27x Processor Family Mapping Tables .....	4-7
4.2.1	Intel® PXA271 Processor (1x256Mbit(x16) Flash and 1x256Mbit(x16) SDRAM - 1.8V) .....	4-7
4.2.2	PXA272 Processor (2x256 Mbit(x32) (x16 each die) Flash - 1.8V) .....	4-10
4.2.3	PXA273 Processor (2x128 Mbit(x32) (x16 each die) Flash - 1.8V) .....	4-13
4.3	Pin Use .....	4-14
4.4	Pin Usage .....	4-17
4.5	Signal Types .....	4-31
4.6	Memory Controller Reset and Initialization .....	4-32
4.7	Power-Supply Pins .....	4-33
<b>5</b>	<b>Electrical Specifications</b> .....	5-1
5.1	Absolute Maximum Ratings .....	5-1
5.2	Operating Conditions .....	5-1
5.3	Power-Consumption Specifications .....	5-5
5.4	DC Specification .....	5-6
5.5	Oscillator Electrical Specifications .....	5-6
5.5.1	32.768-kHz Oscillator Specifications .....	5-7
5.5.2	13.000-MHz Oscillator Specifications .....	5-8
5.6	CLK_PIO and CLK_TOUT Specifications .....	5-9
5.7	48 MHz Output Specifications .....	5-10
<b>6</b>	<b>AC Timing Specifications</b> .....	6-1
6.1	AC Test Load Specifications .....	6-1
6.2	Reset and Power Manager Timing Specifications .....	6-2
6.2.1	Power-On Timing Specifications .....	6-2

6.2.2	Hardware Reset Timing	6-4
6.2.3	Watchdog Reset Timing	6-5
6.2.4	GPIO Reset Timing	6-5
6.2.5	Sleep Mode Timing	6-6
6.2.6	Deep-Sleep Mode Timing	6-7
6.2.7	Standby-Mode Timing	6-10
6.2.8	Idle-Mode Timing	6-10
6.2.9	Frequency-Change Timing	6-10
6.2.10	Voltage-Change Timing	6-11
6.3	GPIO Timing Specifications	6-11
6.4	Memory and Expansion-Card Timing Specifications	6-12
6.4.1	Internal SRAM Read/Write Timing Specifications	6-12
6.4.2	SDRAM Parameters and Timing Diagrams	6-12
6.4.3	ROM Parameters and Timing Diagrams	6-18
6.4.4	Flash Memory Parameters and Timing Diagrams	6-23
6.4.5	SRAM Parameters and Timing Diagrams	6-33
6.4.6	Variable-Latency I/O Parameters and Timing Diagrams	6-36
6.4.7	Expansion-Card Interface Parameters and Timing Diagrams	6-40
6.5	LCD Timing Specifications	6-43
6.6	SSP Timing Specifications	6-44
6.7	JTAG Boundary Scan Timing Specifications	6-45
<b>Appendix A</b>		<b>A-1</b>
<b>Glossary</b>		<b>Glossary-1</b>

## Figures

2-1	Intel® PXA27x Processor Family Block Diagram, Typical System	2-2
3-1	14 x 14 mm Intel® PXA27x Processor Family Package, Top View	3-1
3-2	14 x 14 mm Intel® PXA27x Processor Family Package, Top View	3-2
3-3	14 x 14-mm Intel® PXA27x Processor Family Package, Side View	3-2
3-4	Processor Markings, Intel® PXA27x Processor Family	3-4
3-5	Intel® PXA27x Product Information Decoder	3-4
4-1	1.8V Intel® PXA27x Processor Family Ball Map, Top Left Quarter	4-3
4-2	1.8V Intel® PXA27x Processor Family Ball Map, Top Right Quarter	4-4
4-3	1.8V Intel® PXA27x Processor Family Ball Map, Bottom Left Quarter	4-5
4-4	1.8V Intel® PXA27x Processor Family Ball Map, Bottom Right Quarter	4-6
6-1	AC Test Load	6-2
6-2	Power On Reset Timing	6-3
6-3	Hardware Reset Timing	6-4
6-4	GPIO Reset Timing	6-5
6-5	Sleep Mode Timing	6-7
6-6	Deep-Sleep-Mode Timing	6-8
6-7	SDRAM Timing	6-15
6-8	SDRAM 4-Beat Read/4-Beat Write, Different Banks Timing	6-16
6-9	SDRAM 4-Beat Write/4-Beat Write, Same Bank-Same Row Timing	6-17
6-10	SDRAM Fly-by DMA Timing	6-18
6-11	32-Bit Non-burst ROM, SRAM, or Flash Read Timing	6-20
6-12	32-Bit Burst-of-Eight ROM or Flash Read Timing	6-21



6-13 Eight-Beat Burst Read from 16-Bit Burst-of-Four ROM or Flash Timing.....	6-22
6-14 16-bit ROM/Flash/SRAM Read for 4/2/1 Bytes Timing .....	6-23
6-15 Synchronous Flash Burst-of-Eight Read Timing .....	6-26
6-16 Synchronous Flash Stacked Burst-of-Eight Read Timing .....	6-27
6-17 First-Access Latency Configuration Timing.....	6-28
6-18 Synchronous Flash Burst Read Example.....	6-30
6-19 32-Bit Flash Write Timing.....	6-31
6-20 32-Bit Stacked Flash Write Timing.....	6-32
6-21 16-Bit Flash Write Timing.....	6-33
6-22 32-Bit SRAM Write Timing .....	6-35
6-23 16-bit SRAM Write for 4/2/1 Byte(s) Timing .....	6-36
6-24 32-Bit VLIO Read Timing .....	6-38
6-25 32-Bit VLIO Write Timing.....	6-39
6-26 Expansion-Card Memory or I/O 16-Bit Access Timing.....	6-41
6-27 Expansion-Card Memory or I/O 16-Bit Access to 8-Bit Device Timing .....	6-42
6-28 LCD Timing Definitions.....	6-43
6-29 SSP Master Mode Timing Definitions.....	6-44
6-30 Timing Diagram for SSP Slave Mode Transmitting Data to an External Peripheral.....	6-44
6-31 Timing Diagram for SSP Slave Mode Receiving Data from External Peripheral.....	6-45
6-32 JTAG Boundary-Scan Timing.....	6-46

## Tables

1-1 Supplemental Documentation .....	1-2
3-1 Intel® PXA27x Processor Family Package Information .....	3-2
3-2 Processor Material Properties .....	3-3
3-3 Intel® PXA27x Processor Family ID Markings.....	3-5
4-1 1x256Mbit(x16) Flash and 1x256Mbit(x16) SDRAM - 1.8V .....	4-7
4-2 2x256 Mbit(x32) (x16 each die) Flash - 1.8V .....	4-10
4-3 2x128Mbit(x32) (x16 each die) Flash - 1.8V .....	4-14
4-4 SCSP Pin Usage Summary.....	4-17
4-5 Pin Usage and Mapping Notes.....	4-31
4-6 Signal Types.....	4-32
4-7 Memory Controller Pin Reset Values .....	4-32
4-8 SCSP 1.8V Power Supply Pin Summary .....	4-33
5-1 Absolute Maximum Ratings.....	5-1
5-2 Voltage, Temperature, and Frequency Electrical Specifications.....	5-2
5-3 Memory Voltage and Frequency Electrical Specifications .....	5-3
5-4 Core Voltage and Frequency Electrical Specifications.....	5-4
5-5 Internally Generated Power Domain Descriptions .....	5-5
5-6 Core Voltage Specifications For Lower Power Modes .....	5-5
5-7 Standard Input, Output, and I/O Pin DC Operating Conditions .....	5-6
5-8 Typical 32.768-kHz Crystal Requirements .....	5-7
5-9 Typical External 32.768-kHz Oscillator Requirements .....	5-8
5-10 Typical 13.000-MHz Crystal Requirements.....	5-8
5-11 Typical External 13.000-MHz Oscillator Requirements.....	5-9
5-12 CLK_PIO Specifications .....	5-9
5-13 CLK_TOUT Specifications .....	5-9
5-14 48 MHz Output Specifications .....	5-10



6-1	Standard Input, Output, and I/O-Pin AC Operating Conditions .....	6-1
6-2	Power-On Timing Specifications (OSCC[CRI] = 0) .....	6-3
6-3	Hardware Reset Timing Specifications (OSCC[CRI] = 0) .....	6-4
6-4	Hardware Reset Timing Specifications (OSCC[CRI] = 1) .....	6-5
6-5	GPIO Reset Timing Specifications .....	6-6
6-6	Sleep-Mode Timing Specifications .....	6-7
6-7	Deep-Sleep Mode Timing Specifications .....	6-8
6-8	GPIO Pu/Pd Timing Specifications for Deep-Sleep Mode .....	6-9
6-9	Standby-Mode Timing Specifications .....	6-10
6-10	Idle-Mode Timing Specifications .....	6-10
6-11	Frequency-Change Timing Specifications .....	6-10
6-12	Voltage-Change Timing Specification for a 1-Byte Command .....	6-11
6-13	GPIO Timing Specifications .....	6-11
6-14	SRAM Read/Write AC Specification .....	6-12
6-15	SDRAM Interface AC Specifications .....	6-13
6-16	ROM AC Specification .....	6-18
6-17	Synchronous Flash Read AC Specifications .....	6-24
6-18	Flash Memory AC Specification .....	6-30
6-19	SRAM Write AC Specification .....	6-34
6-20	VLIO Timing .....	6-37
6-21	Expansion-Card Interface AC Specifications .....	6-40
6-22	LCD Timing Specifications .....	6-43
6-23	SSP Master Mode Timing Specifications .....	6-44
6-24	Timing Specification for SSP Slave Mode Transmitting Data to External Peripheral .....	6-45
6-25	Timing Specification for SSP Slave Mode Receiving Data from External Peripheral .....	6-45
6-26	Boundary Scan Timing Specifications .....	6-45

§§



# Introduction

# 1

The Intel® PXA27x Processor Family (Intel PXA27x processor family) provides industry-leading multimedia performance, low-power capabilities, rich peripheral integration and second generation memory stacking. Designed from the ground up for wireless clients, it incorporates the latest Intel advances in mobile technology over its predecessor, the Intel® PXA255 processor. The Intel PXA27x processor family redefines scalability by operating from 104 MHz up to 520 MHz, providing enough performance for the most demanding mobile applications.

The Intel PXA27x processor family is the first Intel processor to include Intel® Wireless MMX™ technology, enabling high-performance, low-power multimedia acceleration with a general-purpose instruction set. Intel® Quick Capture technology provides a flexible and powerful camera interface for capturing digital images and video. While performance is key in the Intel PXA27x processor family, power consumption is also a critical component. The new capabilities of Wireless Intel SpeedStep® technology set the standard for low-power consumption.

The Intel PXA27x processor family is available in both discrete and stacked versions in the following configurations:

- Intel® PXA271 processor (Intel PXA271 processor) with 32 MBytes of Intel StrataFlash® Memory and 32 MBytes of Low-Power SDRAM
- Intel® PXA272 processor (Intel PXA272 processor) with 64 MBytes of Intel StrataFlash® Memory
- Intel® PXA273 processor (Intel PXA273 processor) 32 MBytes of Intel StrataFlash® Memory

## 1.1 About This Document

This document constitutes the electrical, mechanical, and thermal specifications for the Intel PXA27x processor. It contains a functional overview, mechanical data, package signal locations, targeted electrical specifications, and functional bus waveforms. For detailed functional descriptions other than parametric performance, refer to the *Intel® PXA27x Processor Family Developers Manual*.

### 1.1.1 Number Representation

All numbers in this document are **base 10** unless designated otherwise. Hexadecimal numbers have a prefix of 0x, and binary numbers have a prefix of 0b. For example, 107 is represented as 0x6B in hexadecimal and 0b110\_1011 in binary.

### 1.1.2 Typographical Conventions

All signal and register-bit names appear in uppercase. Active low items are prefixed with a lowercase “n”.

Bits within a signal name are enclosed in angle brackets:



EXTERNAL\_ADDRESS<31:0>  
 nCS<1>

Bits within a register bit field are enclosed in square brackets:

REGISTER\_BITFIELD[3:0]  
 REGISTER\_BIT[0]

Single-bit items have either of two states:

- **clear** — the item contains the value 0b0. To clear a bit, write 0b0 to it.
- **set** — the item contains the value 0b1. To set a bit, write 0b1 to it.

### 1.1.3 Applicable Documents

Table 1-1 lists supplemental information sources for the Intel PXA27x processor family. Contact an Intel representative for the latest document revisions and ordering instructions.

**Table 1-1. Supplemental Documentation**

<b>Document Title</b>
<i>Intel® PXA27x Processor Family Developers Manual</i>
<i>ARM® Architecture Version 5T Specification</i> (Document number ARM* DDI 0100D-10), and <i>ARM® Architecture Reference Manual</i> (Document number ARM* DDI 0100B)
<i>Intel® XScale™ Core Developer's Manual</i>
<i>Intel® Wireless MMX™ Technology Developer's Guide</i>
<i>Intel® PXA27x Processor Design Guide</i>
<i>Intel® PXA27x Processor Power Supply Requirements Application Note</i>
<i>Intel® 128L30+128SDRAM Datasheet</i>
<i>Intel® 256L18+256SDRAM Datasheet</i>

§§





## Functional Overview

---

## 2

The Intel® PXA27x Processor Family (Intel PXA27x processor family) is an integrated system-on-a-chip microprocessor for high performance, dynamic, low-power portable handheld and hand-set devices. It incorporates the Intel XScale® technology which complies with the ARM\* version 5TE instruction set (excluding floating-point instructions) and follows the ARM\* programmer's model. The Intel PXA27x processor family also provides Intel® Wireless MMX™ media enhancement technology, which supports integer instructions to accelerate audio and video processing. In addition, it incorporates Wireless Intel Speedstep® Technology, which provides sophisticated power management capabilities enabling excellent MIPS/mW performance.

The Intel PXA27x processor family provides a scalable, bi-directional data interface to a cellular baseband processor, supporting seven logical channels and other features. The operating-system (OS) timer channels and synchronous serial ports (SSPs) also accept an external network clock input so that they can be synchronized to the cellular network. The processor also provides a Universal Subscriber Identity Module\* (USIM) card interface.

The Intel PXA27x processor memory interface gives designers flexibility as it supports a variety of external memory types. The processor also provides four 64 kilobyte banks of on-chip SRAM, which can be used for program code or multimedia data. Each bank can be configured independently to retain its contents when the processor enters a low-power mode. An integrated LCD panel controller supports displays up to 800 by 600 pixels, permitting 1-, 2-, 4-, and 8-bit gray scale and 1-, 2-, 4-, 8-, 16-, 18-, and 24-bit color pixels. A 256-byte palette RAM provides flexible color mapping.

A set of serial devices and general-system resources offers computational and connectivity capability for a variety of applications. [Figure 2-1](#) shows the block diagram for a typical Intel PXA27x processor system.

Figure 2-1. Intel® PXA27x Processor Family Block Diagram, Typical System

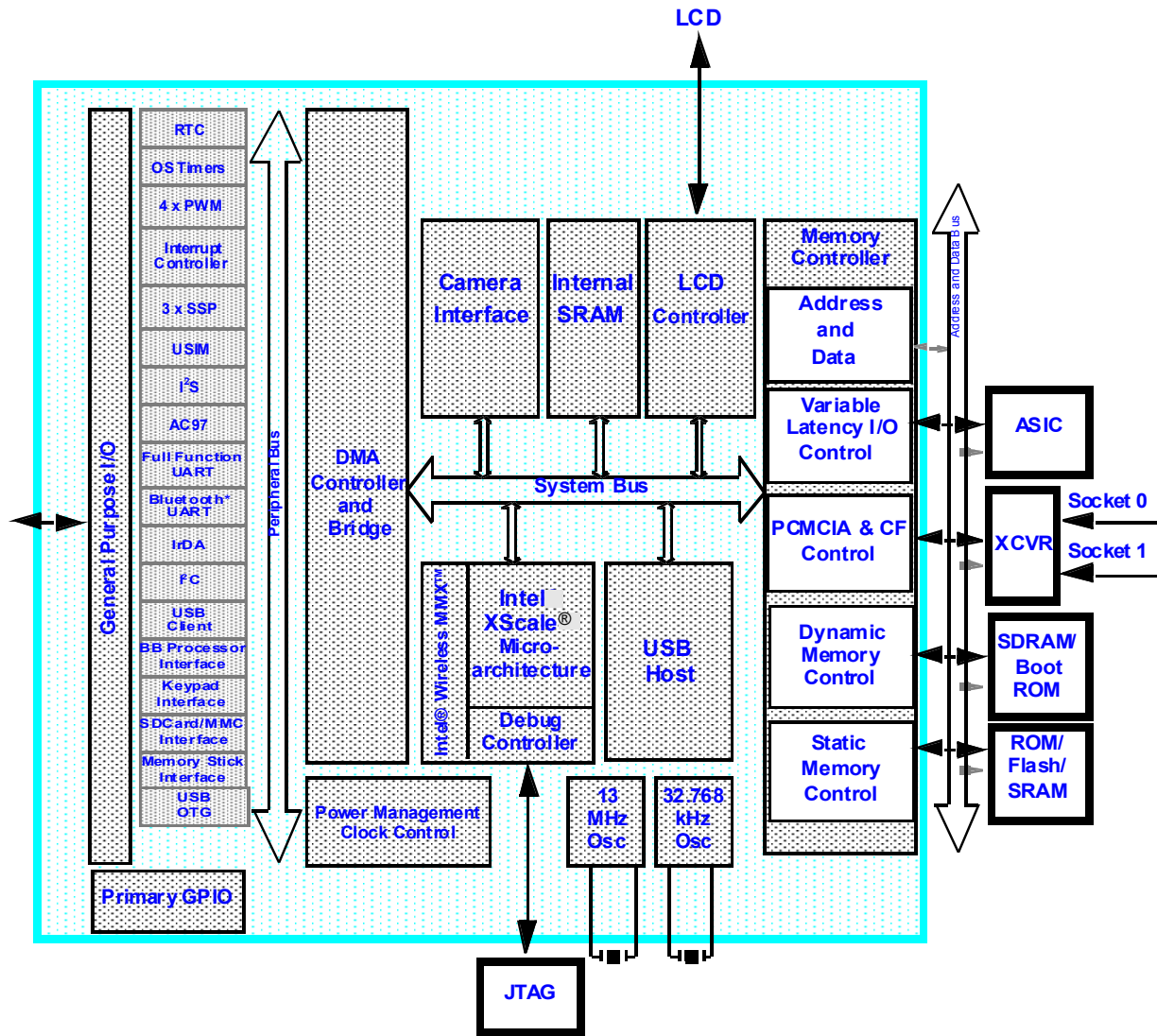

§§

# Package Information

# 3

This chapter provides the mechanical specifications for the Intel® PXA27x Processor Family (Intel PXA27x processor family).

## 3.1 Package Information

**Figure 3-1. 14 x 14 mm Intel® PXA27x Processor Family Package, Top View**

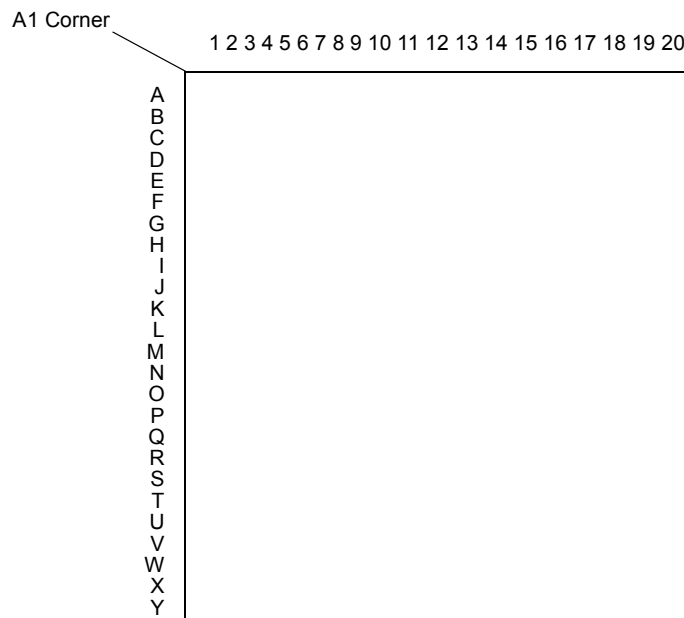

The Intel PXA27x processor family has the following characteristics:

- Ball pitch: 0.65mm
- Ball diameter: 0.30 mm
- Substrate thickness: 0.21 mm
- Mold thickness: 0.45 mm

The Intel PXA27x processor family is packaged in a 14- by 14-mm, 336-pin, 0.65-mm package, as shown in [Figure 3-2](#) and [Figure 3-3](#).

Refer to [Table 3-1](#) for package configuration information for [Figure 3-1](#) and [Figure 3-2](#).

### 3.2 Processor Materials

**Figure 3-2. 14 x 14 mm Intel® PXA27x Processor Family Package, Top View**

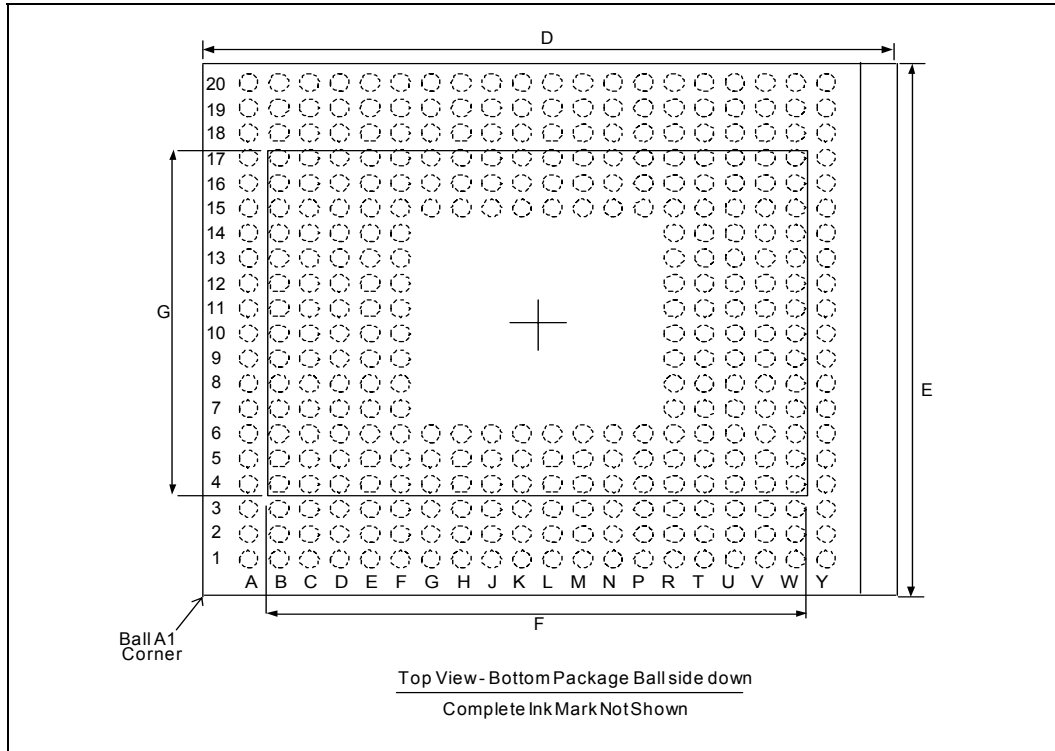

**Figure 3-3. 14 x 14-mm Intel® PXA27x Processor Family Package, Side View**

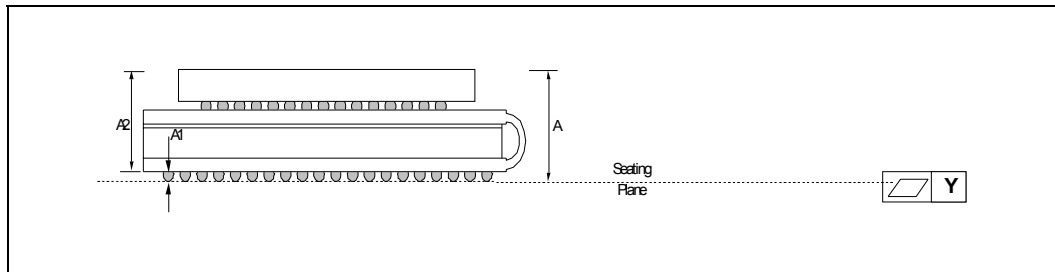

**Table 3-1. Intel® PXA27x Processor Family Package Information (Sheet 1 of 2)**

Dimension	Symbol	Min	Typical	Max
Package Height	A			1.55
Ball Height	A1	0.180		
Package Body Thickness	A2	1.121		1.195
Ball (Lead) Width	b	0.350	0.4	0.450
Bottom Package Body Width	D	13.9	14	14.1
Bottom Package Body Length	E	13.9	14	14.1

**Table 3-1. Intel® PXA27x Processor Family Package Information (Sheet 2 of 2)**

Dimension	Symbol	Min	Typical	Max
Top Package Body Width	F	10.9	11	11.1
Top Package Body Length	G	12.9	13	13.1
Pitch	[e]		0.650	
Ball (Lead) Count	N		336	
Seating Plane Coplanarity	Y			0.150
Corner to Ball A1 Distance Along D	S1		0.825	
Corner to Ball A1 Distance Along E	S2		0.825	

Table 3-2 describes the basic material properties of the processor components.

**Table 3-2. Processor Material Properties**

Component	Material
Mold compound	ShinEtsu KMC 2500 VAT1
Solder balls	63 Sn/37 Pb <sup>†</sup>
<sup>†</sup> Subsequent processor steppings may use Pb-free (94.5 Sn/5.0 Ag/ 0.5 Cu) balls.	

### 3.3 Junction To Case Temperature Thermal Resistance

Parameter	Value and Units
Theta Jc	2 degrees C / watt

### 3.4 Processor Markings

Figure 3-4 details the processor top markings, which identify the Intel PXA27x processor family in the 336-pin package. Refer to Table 3-1 for product information.

**Figure 3-4. Processor Markings, Intel® PXA27x Processor Family**

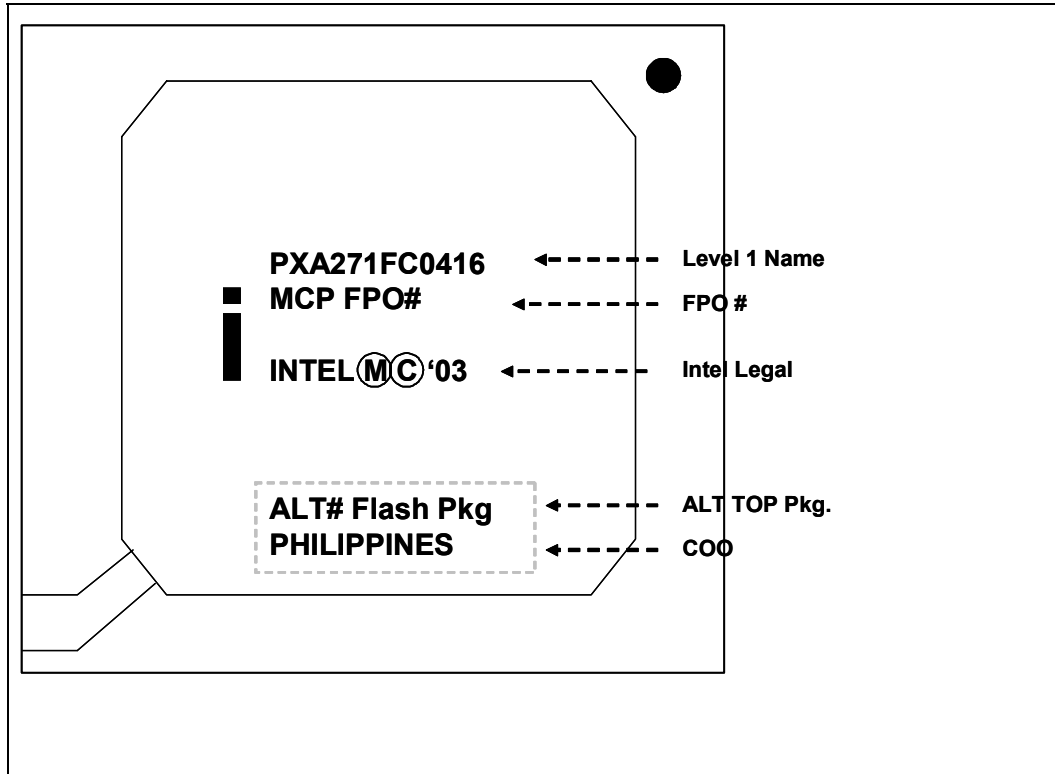

**Figure 3-5. Intel® PXA27x Product Information Decoder (see also Table 3-3)**

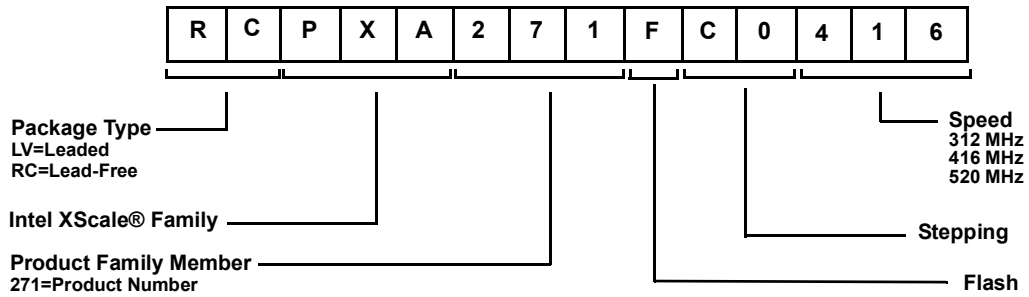



## 3.5 Intel® PXA27x Processor Family Identification Markings

Table 3-3 shows the stacked memory configuration for each of the Intel PXA27x processor family packages. Refer to Figure 3-5 to decode product information in Table 3-3.

**Table 3-3. Intel® PXA27x Processor Family ID Markings**

PXA	PXA27x Package Stepping	Level 1 Name <sup>1</sup>	Apps Processor CPU Stepping	Stacked Memory Configuration	Reference Documentation
PXA271	C0	LVPXA271FC0	C0	1x256 Mbit x 16 Flash + 1x256 Mbit x 16 SDRAM	-Intel® PXA27x Memory Subsystem (x16) with LPSPDRAM Data Sheet Order No. 301855-001
PXA272	C0	LVPXA272FC0	C0	2x256Mbit x 32 Flash	-Intel® PXA27x Memory Subsystem (x32) Data Sheet Order No. 301854-001
PXA273	C0	LVPXA273FC0	C0	2x128Mbit x 32 Flash	
<b>NOTES:</b> 1. From Top Package markings in figures above 2. A Pb-Free (lead-free) package is indicated by the letter "E" on the 4th line of information (Intel legal line). The "E" appears after the date stamp					

## 3.6 Tray Drawing

For tray drawing information, refer to the Intel Developer website for the *Intel® Wireless Communications and Computing Package Users Guide*.

§§







# Pin Listing and Signal Definitions

---

# 4

This chapter describes the signals and pins for the Intel® PXA27x Processor Family (PXA27x processor).

For descriptions of all signals, refer to the “System Architecture” chapter in the *Intel® PXA27x Processor Family Developer’s Manual*.

[Table 4-4](#) lists the mapping of signals to specific package pins. Many of the package pins are multiplexed so that they can be configured for use as a general purpose I/O signal or as one of two or three alternate functions using the GPIO alternate-function select registers. Some signals can be configured to appear on one of several different package pins.

[Table 4-1](#) through [Table 4-3](#) shows the PXA27x memory-specific balls and connectivity within the package.



## 4.1 Ball Map View

**Note:** In the following ball map figures the lowercase letter “n”, which normally indicates negation, appears as uppercase “N”.

### 4.1.1 1.8V SCSP Ball Map

Figure 4-1 through Figure 4-4 shows the ball map for all of the 1.8V PXA27x devices. The following options are available:

- Intel® PXA271 Processor - 1x256Mbit(x16) flash and 1x256MBit(x16) SDRAM 1.8V
- Intel® PXA272 Processor - 2x256Mbit(x32) flash (x16 each die) 1.8V
- Intel® PXA273 Processor - 2x128Mbit(x32) flash (x16 each die) 1.8V

**Figure 4-1. 1.8V Intel® PXA27x Processor Family Ball Map, Top Left Quarter**

	1	2	3	4	5	6	7	8	9	10
A	VCC_USB	VCC_USB	GPIO<89>	GPIO<42>	USBH_N<1>	USBH_P<1>	GPIO<90>	GPIO<61>	GPIO<65>	GPIO<71>
B	GPIO<118>	GPIO<119>	GPIO<88>	GPIO<43>	GPIO<115>	UIO	VCC_CORE	VCC_LCD	VCC_CORE	GPIO<70>
C	VSS_CORE	USBC_N	GPIO<120>	GPIO<116>	GPIO<114>	VCC_USIM	GPIO<91>	GPIO<63>	GPIO<64>	GPIO<69>
D	VCC_USB	USBC_P	GPIO<44>	GPIO<39>	GPIO<41>	VSS_IO	GPIO<58>	GPIO<59>	VSS_IO	GPIO<68>
E	VCC_CORE	GPIO<117>	GPIO<35>	VSS_IO	GPIO<109>	GPIO<16>	VSS_CORE	GPIO<62>	GPIO<66>	VSS_CORE
F	GPIO<45>	GPIO<34>	GPIO<32>	GPIO<110>	GPIO<111>	GPIO<25>	GPIO<22>	GPIO<60>	VSS_CORE	GPIO<67>
G	GPIO<112>	GPIO<92>	GPIO<17>	GPIO<36>	GPIO<37>	GPIO<30>				
H	GPIO<23>	GPIO<24>	GPIO<26>	GPIO<27>	GPIO<38>	GPIO<46>				
J	VCC_IO	VSS_IO	GPIO<40>	GPIO<31>	VSS_CORE	GPIO<11>				
K	GPIO<28>	GPIO<29>	VCC_CORE	GPIO<113>	GPIO<47>	VSS_CORE				

**Figure 4-2. 1.8V Intel® PXA27x Processor Family Ball Map, Top Right Quarter**

11	12	13	14	15	16	17	18	19	20	
VCC_LCD	VCC_CORE	TESTCLK	GPIO<9>	GPIO<0>	NRESET	TXTAL_OUT	VSS	VSS	VSS	<b>A</b>
VCC_CORE	GPIO<14>	VSS_IO	TDI	GPIO<4>	PWR_EN	TXTAL_IN	BOOT_SEL	NRESET_OUT	VSS	<b>B</b>
GPIO<86>	GPIO<75>	TMS	NTRST	VSS	GPIO<3>	NVDD_FAULT	NBATT_FAULT	PWR_CAP<0>	VSS	<b>C</b>
GPIO<87>	GPIO<76>	GPIO<77>	TDO	GPIO<10>	GPIO<1>	SYS_EN	PWR_CAP<1>	VSS	PWR_OUT	<b>D</b>
GPIO<72>	VSS_IO	GPIO<74>	TCK	CLK_REQ	PWR_CAP<3>	VCC_BATT	PWR_CAP<2>	PXTAL_IN	PXTAL_OUT	<b>E</b>
VSS_CORE	GPIO<73>	VSS_CORE	GPIO<19>	GPIO<97>	GPIO<94>	GPIO<96>	VCC_PLL	VSS_PLL	VSS_IO	<b>F</b>
				VSS_IO	GPIO<100>	GPIO<99>	GPIO<98>	GPIO<93>	GPIO<95>	<b>G</b>
				VSS_CORE	GPIO<106>	GPIO<104>	GPIO<101>	GPIO<102>	VCC_IO	<b>H</b>
				GPIO<51>	GPIO<108>	GPIO<107>	GPIO<105>	VCC_CORE	GPIO<103>	<b>J</b>
				GPIO<81>	VSS_BB	GPIO<50>	GPIO<52>	GPIO<53>	GPIO<54>	<b>K</b>

**Figure 4-3. 1.8V Intel® PXA27x Processor Family Ball Map, Bottom Left Quarter**

<b>L</b>	VCC_IO	VSS_IO	GPIO<12>	GPIO<13>	MD<30>	MD<29>				
<b>M</b>	GPIO<49>	GPIO<18>	VCC_SRAM	RDNWR	MD<31>	MD<14>				
<b>N</b>	VCC_MEM	VSS_MEM	VCC_SRAM	VSS_CORE	MA<6>	MD<15>				
<b>P</b>	GPIO<80>	MA<18>	GPIO<79>	MA<10>	MA<9>	MA<3>				
<b>R</b>	VCC_MEM	VCC_CORE	VCC_SRAM	MA<19>	MA<15>	MA<7>	MA<4>	MD<13>	MD<12>	MD<11>
<b>T</b>	VSS_MEM	VCC_MEM	GPIO<33>	MA<20>	MA<16>	MA<12>	MA<8>	MA<2>	MD<28>	MD<27>
<b>U</b>	VCC_CORE	VSS_CORE	VCC_SRAM	VSS_CORE	VSS_MEM	MA<13>	VSS_MEM	VSS_MEM	VSS_MEM	VSS_MEM
<b>V</b>	GPIO<15>	MA<25>	VSS_CORE	GPIO<78>	VCC_MEM	MA<14>	VCC_MEM	VCC_MEM	VCC_MEM	VCC_MEM
<b>W</b>	NCS<0>	MA<24>	MA<0>	MA<23>	MA<21>	MA<17>	MA<11>	MA<5>	RFU	F_VPP
<b>Y</b>	VSS_CORE	VSS_MEM	MA<1>	MA<22>	VSS_MEM	VCC_MEM	VCC_MEM	NF_RST	VSS_MEM	VCC_MEM
	<b>1</b>	<b>2</b>	<b>3</b>	<b>4</b>	<b>5</b>	<b>6</b>	<b>7</b>	<b>8</b>	<b>9</b>	<b>10</b>

**Figure 4-4. 1.8V Intel® PXA27x Processor Family Ball Map, Bottom Right Quarter**

				GPIO<85>	GPIO<55>	GPIO<57>	GPIO<48>	VCC_CORE	VCC_BB	<b>L</b>
				MD<5>	MD<4>	MD<1>	GPIO<56>	GPIO<83>	GPIO<84>	<b>M</b>
				MD<21>	MD<17>	MD<16>	VSS_MEM	GPIO<82>	VCC_MEM	<b>N</b>
				MD<23>	MD<2>	DQM<1>	VSS_MEM	SDCLK<1>	VCC_MEM	<b>P</b>
MD<26>	MD<25>	VSS_CORE	MD<8>	MD<22>	VSS_CORE	NSDCS<1>	GPIO<21>	VCC_MEM	VCC_CORE	<b>R</b>
MD<10>	MD<9>	VCC_CORE	MD<6>	VCC_CORE	MD<18>	DQM<2>	SDCKE	SDCLK<2>	GPIO<20>	<b>T</b>
VSS_MEM	VSS_MEM	MD<24>	VSS_MEM	MD<19>	VSS_MEM	MD<0>	VSS_CORE	VSS_MEM	NSDCAS	<b>U</b>
VCC_MEM	VCC_MEM	MD<7>	VCC_MEM	MD<3>	VCC_MEM	VCC_MEM	NSDCS<0>	SDCLK<3>	SDCLK<0>	<b>V</b>
VSS_MEM	RFU	RFU	MD<20>	NF_WP<0>	RFU	DQM<3>	DQM<0>	NOE	NWE	<b>W</b>
VCC_MEM	VCC_MEM	VCC_MEM	NF_WP<1>	RFU	VCC_MEM	VSS_MEM	RFU	NSDRAS	VCC_MEM	<b>Y</b>
<b>11</b>	<b>12</b>	<b>13</b>	<b>14</b>	<b>15</b>	<b>16</b>	<b>17</b>	<b>18</b>	<b>19</b>	<b>20</b>	

**Note:** “RFU” means “reserved for future use.” Do not connect.



## 4.2 Intel® PXA27x Processor Family Mapping Tables

### 4.2.1 Intel® PXA271 Processor (1x256Mbit(x16) Flash and 1x256Mbit(x16) SDRAM - 1.8V)

Table 4-1 lists the ball names and position of the 1.8V PXA271 processor memory-specific balls and shows where they connect internally to the PXA27x processor, flash, and SDRAM. Use with Table 4-4 for complete ball-out information. Refer to the memory data sheet for the 1.8V PXA27x Processor Family memory signal descriptions.

**Table 4-1. 1x256Mbit(x16) Flash and 1x256Mbit(x16) SDRAM - 1.8V (Sheet 1 of 4)**

Ball#	Type	Ball Name	SDRAM	Flash (L18) <sup>2</sup>	PXA271
W18	Input	DQM<0>	D-DM[1]	—	DQM<0>
P17	Input	DQM<1>	D-DM[0]	—	DQM<1>
T17	Input	DQM<2>	—	—	DQM<2>
W17	Input	DQM<3>	—	—	DQM<3>
W1	Input	NCS<0>	—	F1-CE#	nCS<0>
V18	Input	NSDCS<0>	D1-CS#	—	nSDCS<0>
W20	Input	NWE	WE#	WE#	nWE
W19	Input	NOE	—	OE#	nOE
U20	Input	NSDCAS	D-CAS	ADV#	nSDCAS
Y19	Input	NSDRAS	D-RAS	—	nSDRAS
V19	Input	SDCLK<3>	—	F-CLK	SDCLK<3>
P19	Input	SDCLK<1>	R-CLK	—	SDCLK<1>
T18	Input	SDCKE	D-CKE	—	SDCKE
W15	Input	NF_WP<0>	—	F-WP1#	—
N6	Bidirectional	MD<15>	D0	D15	MD<15>
M6	Bidirectional	MD<14>	D1	D14	MD<14>
R8	Bidirectional	MD<13>	D3	D13	MD<13>
R9	Bidirectional	MD<12>	D2	D12	MD<12>
R10	Bidirectional	MD<11>	D5	D11	MD<11>
T11	Bidirectional	MD<10>	D4	D10	MD<10>
T12	Bidirectional	MD<9>	D7	D9	MD<9>
R14	Bidirectional	MD<8>	D6	D8	MD<8>
V13	Bidirectional	MD<7>	D9	D7	MD<7>
T14	Bidirectional	MD<6>	D8	D6	MD<6>
M15	Bidirectional	MD<5>	D11	D5	MD<5>
M16	Bidirectional	MD<4>	D10	D4	MD<4>
V15	Bidirectional	MD<3>	D13	D3	MD<3>
P16	Bidirectional	MD<2>	D12	D2	MD<2>
M17	Bidirectional	MD<1>	D15	D1	MD<1>

**Table 4-1. 1x256Mbit(x16) Flash and 1x256Mbit(x16) SDRAM - 1.8V (Sheet 2 of 4)**

Ball#	Type	Ball Name	SDRAM	Flash (L18) <sup>2</sup>	PXA271
U17	Bidirectional	MD<0>	D14	D0	MD<0>
V2	Input	MA<25>	—	—	MA<25>
W2	Input	MA<24>	D-BA1	A23	MA<24>
W4	Input	MA<23>	D-BA0	A22	MA<23>
Y4	Input	MA<22>	—	A21	MA<22>
W5	Input	MA<21>	—	A20	MA<21>
T4	Input	MA<20>	—	A19	MA<20>
R4	Input	MA<19>	—	A18	MA<19>
P2	Input	MA<18>	—	A17	MA<18>
W6	Input	MA<17>	—	A16	MA<17>
T5	Input	MA<16>	—	A15	MA<16>
R5	Input	MA<15>	—	A14	MA<15>
V6	Input	MA<14>	—	A13	MA<14>
U6	Input	MA<13>	A12	A12	MA<13>
T6	Input	MA<12>	A11	A11	MA<12>
W7	Input	MA<11>	A10	A10	MA<11>
P4	Input	MA<10>	A9	A9	MA<10>
P5	Input	MA<9>	A8	A8	MA<9>
T7	Input	MA<8>	A7	A7	MA<8>
R6	Input	MA<7>	A6	A6	MA<7>
N5	Input	MA<6>	A5	A5	MA<6>
W8	Input	MA<5>	A4	A4	MA<5>
R7	Input	MA<4>	A3	A3	MA<4>
P6	Input	MA<3>	A2	A2	MA<3>
T8	Input	MA<2>	A1	A1	MA<2>
Y3	Input	MA<1>	A0	A0 <sup>2</sup>	MA<1>
W3	Input	MA<0>	—	—	MA<0>
Y8	Input	NF_RST	—	F-RST#	—
W10	Supply	F_VPP	—	F-VPP	—



**Table 4-1. 1x256Mbit(x16) Flash and 1x256Mbit(x16) SDRAM - 1.8V (Sheet 3 of 4)**

Ball#	Type	Ball Name	SDRAM	Flash (L18) <sup>2</sup>	PXA271
N1/ T2/ V5/ V7/ V8/ V9/ V10/ V11/ V12/ V14/ V16/ V17/ R19/ N20/ P20/ R1/ Y6/ Y7/ Y10/ Y11/ Y12/ Y13/ Y16/ Y20/	Supply	VCC_MEM	VCCQ	VCCQ	VCC_MEM
U19/ Y2/ N2/ N18/ P18/ T1/ U5/ U7/ U8/ U9/ U10/ U11/ U12/ U14/ U16/ W11/ Y5/ Y9/ Y17	Supply	VSS_MEM	VSSQ	VSSQ	VSS_MEM
A18/ A19/ A20/ B20/ C20/ C15/ D19	Supply	VSS	VSS	VSS	VSS

**Table 4-1. 1x256Mbit(x16) Flash and 1x256Mbit(x16) SDRAM - 1.8V (Sheet 4 of 4)**

Ball#	Type	Ball Name	SDRAM	Flash (L18) <sup>2</sup>	PXA271
W9/ W12/ W13/ W16/ Y15/ Y18	RFU	RFU	—	—	—
Y14	Input	NF_WP<1> <sup>1</sup>	—	—	—

**NOTES:**

1. NF\_WP<1> is reserved for a stacked data flash memory write protect pin (not yet available in current PXA27x processor configurations), in the top package.
2. Address signals within this table align with those found in the discrete flash datasheet. Address signals in the stacked datasheet are shifted by one for 16-bit flash and by two for 32-bit flash to align the stack ballout for processor/system design.

## 4.2.2 PXA272 Processor (2x256 Mbit(x32) (x16 each die) Flash - 1.8V)

Table 4-2 lists the ball names and position of the 2x256Mbit (x32) 1.8V PXA272 processor memory-specific balls and shows where they connect internally to the PXA27x processor and flash. Use with Table 4-4 for complete ball-out information.

**Table 4-2. 2x256 Mbit(x32) (x16 each die) Flash - 1.8V (Sheet 1 of 4)**

Ball#	Type	Ball Name	Flash Die 1(L18) <sup>2</sup>	Flash Die 2(L18) <sup>2</sup>	PXA272
W1	Input	NCS<0>	F1-CE#	F1-CE#	nCS<0>
W20	Input	NWE	WE#	WE#	nWE
W19	Input	NOE	OE#	OE#	nOE
U20	Input	NSDCAS	ADV#	ADV#	nSDCAS
V19	Input	SDCLK<3>	F-CLK	F-CLK	SDCLK<3>
W15	Input	NF_WP<0>	F-WP1#	F-WP1#	—
M5	Bidirectional	MD<31>	—	D15	MD<31>
L5	Bidirectional	MD<30>	—	D14	MD<30>
L6	Bidirectional	MD<29>	—	D13	MD<29>
T9	Bidirectional	MD<28>	—	D12	MD<28>
T10	Bidirectional	MD<27>	—	D11	MD<27>
R11	Bidirectional	MD<26>	—	D10	MD<26>
R12	Bidirectional	MD<25>	—	D9	MD<25>
U13	Bidirectional	MD<24>	—	D8	MD<24>
P15	Bidirectional	MD<23>	—	D7	MD<23>
R15	Bidirectional	MD<22>	—	D6	MD<22>
N15	Bidirectional	MD<21>	—	D5	MD<21>
W14	Bidirectional	MD<20>	—	D4	MD<20>
U15	Bidirectional	MD<19>	—	D3	MD<19>
T16	Bidirectional	MD<18>	—	D2	MD<18>

**Table 4-2. 2x256 Mbit(x32) (x16 each die) Flash - 1.8V (Sheet 2 of 4)**

Ball#	Type	Ball Name	Flash Die 1(L18) <sup>2</sup>	Flash Die 2(L18) <sup>2</sup>	PXA272
N16	Bidirectional	MD<17>	—	D1	MD<17>
N17	Bidirectional	MD<16>	—	D0	MD<16>
N6	Bidirectional	MD<15>	D15	—	MD<15>
M6	Bidirectional	MD<14>	D14	—	MD<14>
R8	Bidirectional	MD<13>	D13	—	MD<13>
R9	Bidirectional	MD<12>	D12	—	MD<12>
R10	Bidirectional	MD<11>	D11	—	MD<11>
T11	Bidirectional	MD<10>	D10	—	MD<10>
T12	Bidirectional	MD<9>	D9	—	MD<9>
R14	Bidirectional	MD<8>	D8	—	MD<8>
V13	Bidirectional	MD<7>	D7	—	MD<7>
T14	Bidirectional	MD<6>	D6	—	MD<6>
M15	Bidirectional	MD<5>	D5	—	MD<5>
M16	Bidirectional	MD<4>	D4	—	MD<4>
V15	Bidirectional	MD<3>	D3	—	MD<3>
P16	Bidirectional	MD<2>	D2	—	MD<2>
M17	Bidirectional	MD<1>	D1	—	MD<1>
U17	Bidirectional	MD<0>	D0	—	MD<0>
V2	Input	MA<25>	A23	A23	MA<25>
W2	Input	MA<24>	A22	A22	MA<24>
W4	Input	MA<23>	A21	A21	MA<23>
Y4	Input	MA<22>	A20	A20	MA<22>
W5	Input	MA<21>	A19	A19	MA<21>
T4	Input	MA<20>	A18	A18	MA<20>
R4	Input	MA<19>	A17	A17	MA<19>
P2	Input	MA<18>	A16	A16	MA<18>
W6	Input	MA<17>	A15	A15	MA<17>
T5	Input	MA<16>	A14	A14	MA<16>
R5	Input	MA<15>	A13	A13	MA<15>
V6	Input	MA<14>	A12	A12	MA<14>
U6	Input	MA<13>	A11	A11	MA<13>
T6	Input	MA<12>	A10	A10	MA<12>
W7	Input	MA<11>	A9	A9	MA<11>
P4	Input	MA<10>	A8	A8	MA<10>
P5	Input	MA<9>	A7	A7	MA<9>
T7	Input	MA<8>	A6	A6	MA<8>
R6	Input	MA<7>	A5	A5	MA<7>
N5	Input	MA<6>	A4	A4	MA<6>

**Table 4-2. 2x256 Mbit(x32) (x16 each die) Flash - 1.8V (Sheet 3 of 4)**

Ball#	Type	Ball Name	Flash Die 1(L18) <sup>2</sup>	Flash Die 2(L18) <sup>2</sup>	PXA272
W8	Input	MA<5>	A3	A3	MA<5>
R7	Input	MA<4>	A2	A2	MA<4>
P6	Input	MA<3>	A1	A1	MA<3>
T8	Input	MA<2>	A0 <sup>2</sup>	A0 <sup>2</sup>	MA<2>
Y3	Input	MA<1>	—	—	MA<1>
W3	Input	MA<0>	—	—	MA<0>
Y8	Input	NF_RST	F-RST#	F-RST#	—
W10	Supply	F_VPP	F-VPP	F-VPP	—
N1/ T2/ V5/ V7/ V8/ V9/ V10/ V11/ V12/ V14/ V16/ V17/ R19/ N20/ P20/ R1/ Y6/ Y7/ Y10/ Y11/ Y12/ Y13/ Y16/ Y20/	Supply	VCC_MEM	VCCQ	VCCQ	VCC_MEM
U19/ Y2/ N2/ N18/ P18/ T1/ U5/ U7/ U8/ U9/ U10/ U11/ U12/ U14/ U16/ W11/ Y5/ Y9/ Y17	Supply	VSS_MEM	VSSQ	VSSQ	VSS_MEM

**Table 4-2. 2x256 Mbit(x32) (x16 each die) Flash - 1.8V (Sheet 4 of 4)**

Ball#	Type	Ball Name	Flash Die 1(L18) <sup>2</sup>	Flash Die 2(L18) <sup>2</sup>	PXA272
A18/ A19/ A20/ B20/ C20/ C15/ D19	Supply	VSS	VSS	VSS	VSS
W9/ W12/ W13/ W16/ Y15/ Y18	RFU	RFU	—	—	—
Y14	Input	NF_WP<1> <sup>1</sup>	—	—	—

**NOTES:**

1. NF\_WP<1> is reserved for a stacked data flash memory write protect pin (not yet available in current PXA27x processor configurations), in the top package.
2. Address signals within this table align with those found in the discrete flash datasheet. Address signals in the stacked datasheet are shifted by one for 16-bit flash and by two for 32-bit flash to align the stack ballout for processor/system design.

### 4.2.3 PXA273 Processor (2x128 Mbit(x32) (x16 each die) Flash - 1.8V)

Table 4-3 lists the ball names and position of the 2x128Mbit (x32) 1.8V PXA273 processor memory-specific balls and shows where they connect internally to the PXA273 processor and flash. Use with Table 4-4 for complete ball-out information.

## 4.3 Pin Use

**Table 4-3. 2x128Mbit(x32) (x16 each die) Flash - 1.8V (Sheet 1 of 4)**

Ball#	Type	Ball Name	Flash Die 1(L18) <sup>2</sup>	Flash Die 2(L18) <sup>2</sup>	PXA273
W1	Input	NCS<0>	F1-CE#	F1-CE#	nCS<0>
W20	Input	NWE	WE#	WE#	nWE
W19	Input	NOE	OE#	OE#	nOE
U20	Input	NSDCAS	ADV#	ADV#	nSDCAS
V19	Input	SDCLK<3>	F-CLK	F-CLK	SDCLK<3>
W15	Input	NF_WP<0>	F-WP1#	F-WP1#	—
M5	Bidirectional	MD<31>	—	D15	MD<31>
L5	Bidirectional	MD<30>	—	D14	MD<30>
L6	Bidirectional	MD<29>	—	D13	MD<29>
T9	Bidirectional	MD<28>	—	D12	MD<28>
T10	Bidirectional	MD<27>	—	D11	MD<27>
R11	Bidirectional	MD<26>	—	D10	MD<26>
R12	Bidirectional	MD<25>	—	D9	MD<25>
U13	Bidirectional	MD<24>	—	D8	MD<24>
P15	Bidirectional	MD<23>	—	D7	MD<23>
R15	Bidirectional	MD<22>	—	D6	MD<22>
N15	Bidirectional	MD<21>	—	D5	MD<21>
W14	Bidirectional	MD<20>	—	D4	MD<20>
U15	Bidirectional	MD<19>	—	D3	MD<19>
T16	Bidirectional	MD<18>	—	D2	MD<18>
N16	Bidirectional	MD<17>	—	D1	MD<17>
N17	Bidirectional	MD<16>	—	D0	MD<16>
N6	Bidirectional	MD<15>	D15	—	MD<15>
M6	Bidirectional	MD<14>	D14	—	MD<14>
R8	Bidirectional	MD<13>	D13	—	MD<13>
R9	Bidirectional	MD<12>	D12	—	MD<12>
R10	Bidirectional	MD<11>	D11	—	MD<11>
T11	Bidirectional	MD<10>	D10	—	MD<10>
T12	Bidirectional	MD<9>	D9	—	MD<9>
R14	Bidirectional	MD<8>	D8	—	MD<8>
V13	Bidirectional	MD<7>	D7	—	MD<7>
T14	Bidirectional	MD<6>	D6	—	MD<6>
M15	Bidirectional	MD<5>	D5	—	MD<5>
M16	Bidirectional	MD<4>	D4	—	MD<4>
V15	Bidirectional	MD<3>	D3	—	MD<3>
P16	Bidirectional	MD<2>	D2	—	MD<2>

**Table 4-3. 2x128Mbit(x32) (x16 each die) Flash - 1.8V (Sheet 2 of 4)**

Ball#	Type	Ball Name	Flash Die 1(L18) <sup>2</sup>	Flash Die 2(L18) <sup>2</sup>	PXA273
M17	Bidirectional	MD<1>	D1	—	MD<1>
U17	Bidirectional	MD<0>	D0	—	MD<0>
V2	Input	MA<25>	—	—	MA<25>
W2	Input	MA<24>	A22	A22	MA<24>
W4	Input	MA<23>	A21	A21	MA<23>
Y4	Input	MA<22>	A20	A20	MA<22>
W5	Input	MA<21>	A19	A19	MA<21>
T4	Input	MA<20>	A18	A18	MA<20>
R4	Input	MA<19>	A17	A17	MA<19>
P2	Input	MA<18>	A16	A16	MA<18>
W6	Input	MA<17>	A15	A15	MA<17>
T5	Input	MA<16>	A14	A14	MA<16>
R5	Input	MA<15>	A13	A13	MA<15>
V6	Input	MA<14>	A12	A12	MA<14>
U6	Input	MA<13>	A11	A11	MA<13>
T6	Input	MA<12>	A10	A10	MA<12>
W7	Input	MA<11>	A9	A9	MA<11>
P4	Input	MA<10>	A8	A8	MA<10>
P5	Input	MA<9>	A7	A7	MA<9>
T7	Input	MA<8>	A6	A6	MA<8>
R6	Input	MA<7>	A5	A5	MA<7>
N5	Input	MA<6>	A4	A4	MA<6>
W8	Input	MA<5>	A3	A3	MA<5>
R7	Input	MA<4>	A2	A2	MA<4>
P6	Input	MA<3>	A1	A1	MA<3>
T8	Input	MA<2>	A0 <sup>2</sup>	A0 <sup>2</sup>	MA<2>
Y3	Input	MA<1>	—	—	MA<1>
W3	Input	MA<0>	—	—	MA<0>
Y8	Input	NF_RST	F-RST#	F-RST#	—
W10	Supply	F_VPP	F-VPP	F-VPP	—

**Table 4-3. 2x128Mbit(x32) (x16 each die) Flash - 1.8V (Sheet 3 of 4)**

Ball#	Type	Ball Name	Flash Die 1(L18) <sup>2</sup>	Flash Die 2(L18) <sup>2</sup>	PXA273
N1/ T2/ V5/ V7/ V8/ V9/ V10/ V11/ V12/ V14/ V16/ V17/ R19/ N20/ P20/ R1/ Y6/ Y7/ Y10/ Y11/ Y12/ Y13/ Y16/ Y20/	Supply	VCC_MEM	VCCQ	VCCQ	VCC_MEM
U19/ Y2/ N2/ N18/ P18/ T1/ U5/ U7/ U8/ U9/ U10/ U11/ U12/ U14/ U16/ W11/ Y5/ Y9/ Y17	Supply	VSS_MEM	VSSQ	VSSQ	VSS_MEM
A18/ A19/ A20/ B20/ C20/ C15/ D19	Supply	VSS	VSS	VSS	VSS



**Table 4-3. 2x128Mbit(x32) (x16 each die) Flash - 1.8V (Sheet 4 of 4)**

Ball#	Type	Ball Name	Flash Die 1(L18) <sup>2</sup>	Flash Die 2(L18) <sup>2</sup>	PXA273
W9/ W12/ W13/ W16/ Y15/ Y18	RFU	RFU	—	—	—
Y14	Input	NF_WP<1> <sup>1</sup>	—	—	—

**NOTES:**

1. NF\_WP<1> is reserved for a stacked data flash memory write protect pin (not yet available in current PXA27x processor configurations), in the top package.
2. Address signals within this table align with those found in the discrete flash datasheet. Address signals in the stacked datasheet are shifted by one for 16-bit flash and by two for 32-bit flash to align the stack ballout for processor/system design.

## 4.4 Pin Usage

Table 4-4 shows the Intel PXA27x processor pin-usage summary.

Table 4-4 does not include any of the Intel PXA27x flash and SDRAM dedicated signals. Review Table 4-1, Table 4-2, and Table 4-3 for ball location and mapping of memory signals.

Each signal's alternate function inputs are shown in the upper section of each signal row and the outputs are shown in the lower section of each signal row. For example, GPIO<48> has a primary input function of CIF\_DD<5> and a secondary output function of nPOE.

**Table 4-4. SCSP Pin Usage Summary (Sheet 1 of 14)**

Ball#	Name	Type	Function After Reset	Primary Function	Secondary Alternate Function	Third Alternate Function	Reset State	Sleep State
VCC_MEM								
V2	MA<25>	OCZ	MA<25>	MA<25>	—	—	Note[19]	Note[19]
W2	MA<24>	OCZ	MA<24>	MA<24>	—	—	Note[19]	Note[19]
W4	MA<23>	OCZ	MA<23>	MA<23>	—	—	Note[19]	Note[19]
Y4	MA<22>	OCZ	MA<22>	MA<22>	—	—	Note[19]	Note[19]
W5	MA<21>	OCZ	MA<21>	MA<21>	—	—	Note[19]	Note[19]
T4	MA<20>	OCZ	MA<20>	MA<20>	—	—	Note[19]	Note[19]
R4	MA<19>	OCZ	MA<19>	MA<19>	—	—	Note[19]	Note[19]
P2	MA<18>	OCZ	MA<18>	MA<18>	—	—	Note[19]	Note[19]
W6	MA<17>	OCZ	MA<17>	MA<17>	—	—	Note[19]	Note[19]
T5	MA<16>	OCZ	MA<16>	MA<16>	—	—	Note[19]	Note[19]
R5	MA<15>	OCZ	MA<15>	MA<15>	—	—	Note[19]	Note[19]
V6	MA<14>	OCZ	MA<14>	MA<14>	—	—	Note[19]	Note[19]
U6	MA<13>	OCZ	MA<13>	MA<13>	—	—	Note[19]	Note[19]
T6	MA<12>	OCZ	MA<12>	MA<12>	—	—	Note[19]	Note[19]

**Table 4-4. SCSP Pin Usage Summary (Sheet 2 of 14)**

Ball#	Name	Type	Function After Reset	Primary Function	Secondary Alternate Function	Third Alternate Function	Reset State	Sleep State
W7	MA<11>	OCZ	MA<11>	MA<11>	—	—	Note[19]	Note[19]
P4	MA<10>	OCZ	MA<10>	MA<10>	—	—	Note[19]	Note[19]
P5	MA<9>	OCZ	MA<9>	MA<9>	—	—	Note[19]	Note[19]
T7	MA<8>	OCZ	MA<8>	MA<8>	—	—	Note[19]	Note[19]
R6	MA<7>	OCZ	MA<7>	MA<7>	—	—	Note[19]	Note[19]
N5	MA<6>	OCZ	MA<6>	MA<6>	—	—	Note[19]	Note[19]
W8	MA<5>	OCZ	MA<5>	MA<5>	—	—	Note[19]	Note[19]
R7	MA<4>	OCZ	MA<4>	MA<4>	—	—	Note[19]	Note[19]
P6	MA<3>	OCZ	MA<3>	MA<3>	—	—	Note[19]	Note[19]
T8	MA<2>	OCZ	MA<2>	MA<2>	—	—	Note[19]	Note[19]
Y3	MA<1>	OCZ	MA<1>	MA<1>	—	—	Note[19]	Note[19]
W3	MA<0>	OCZ	MA<0>	MA<0>	—	—	Note[19]	Note[19]
M5	MD<31>	ICOC Z	MD<31>	MD<31>	—	—	Note[19]	Note[19]
L5	MD<30>	ICOC Z	MD<30>	MD<30>	—	—	Note[19]	Note[19]
L6	MD<29>	ICOC Z	MD<29>	MD<29>	—	—	Note[19]	Note[19]
T9	MD<28>	ICOC Z	MD<28>	MD<28>	—	—	Note[19]	Note[19]
T10	MD<27>	ICOC Z	MD<27>	MD<27>	—	—	Note[19]	Note[19]
R11	MD<26>	ICOC Z	MD<26>	MD<26>	—	—	Note[19]	Note[19]
R12	MD<25>	ICOC Z	MD<25>	MD<25>	—	—	Note[19]	Note[19]
U13	MD<24>	ICOC Z	MD<24>	MD<24>	—	—	Note[19]	Note[19]
P15	MD<23>	ICOC Z	MD<23>	MD<23>	—	—	Note[19]	Note[19]
R15	MD<22>	ICOC Z	MD<22>	MD<22>	—	—	Note[19]	Note[19]
N15	MD<21>	ICOC Z	MD<21>	MD<21>	—	—	Note[19]	Note[19]
W14	MD<20>	ICOC Z	MD<20>	MD<20>	—	—	Note[19]	Note[19]
U15	MD<19>	ICOC Z	MD<19>	MD<19>	—	—	Note[19]	Note[19]
T16	MD<18>	ICOC Z	MD<18>	MD<18>	—	—	Note[19]	Note[19]
N16	MD<17>	ICOC Z	MD<17>	MD<17>	—	—	Note[19]	Note[19]

**Table 4-4. SCSP Pin Usage Summary (Sheet 3 of 14)**

Ball#	Name	Type	Function After Reset	Primary Function	Secondary Alternate Function	Third Alternate Function	Reset State	Sleep State
N17	MD<16>	ICOC Z	MD<16>	MD<16>	—	—	Note[19]	Note[19]
N6	MD<15>	ICOC Z	MD<15>	MD<15>	—	—	Note[19]	Note[19]
M6	MD<14>	ICOC Z	MD<14>	MD<14>	—	—	Note[19]	Note[19]
R8	MD<13>	ICOC Z	MD<13>	MD<13>	—	—	Note[19]	Note[19]
R9	MD<12>	ICOC Z	MD<12>	MD<12>	—	—	Note[19]	Note[19]
R10	MD<11>	ICOC Z	MD<11>	MD<11>	—	—	Note[19]	Note[19]
T11	MD<10>	ICOC Z	MD<10>	MD<10>	—	—	Note[19]	Note[19]
T12	MD<9>	ICOC Z	MD<9>	MD<9>	—	—	Note[19]	Note[19]
R14	MD<8>	ICOC Z	MD<8>	MD<8>	—	—	Note[19]	Note[19]
V13	MD<7>	ICOC Z	MD<7>	MD<7>	—	—	Note[19]	Note[19]
T14	MD<6>	ICOC Z	MD<6>	MD<6>	—	—	Note[19]	Note[19]
M15	MD<5>	ICOC Z	MD<5>	MD<5>	—	—	Note[19]	Note[19]
M16	MD<4>	ICOC Z	MD<4>	MD<4>	—	—	Note[19]	Note[19]
V15	MD<3>	ICOC Z	MD<3>	MD<3>	—	—	Note[19]	Note[19]
P16	MD<2>	ICOC Z	MD<2>	MD<2>	—	—	Note[19]	Note[19]
M17	MD<1>	ICOC Z	MD<1>	MD<1>	—	—	Note[19]	Note[19]
U17	MD<0>	ICOC Z	MD<0>	MD<0>	—	—	Note[19]	Note[19]
W19	NOE	OCZ	nOE	nOE	—	—	Note[19]	Note[19]
W20	NWE	OCZ	nWE	nWE	—	—	Note[19]	Note[19]
Y19	NSDRAS	OCZ	nSDRAS	nSDRAS	—	—	Note[19]	Note[19]
U20	NSDCAS	OCZ	nSDCAS	nSDCAS	—	—	Note[19]	Note[19]
W18	DQM<0>	OCZ	DQM<0>	DQM<0>	—	—	Note[19]	Note[19]
P17	DQM<1>	OCZ	DQM<1>	DQM<1>	—	—	Note[19]	Note[19]
T17	DQM<2>	OCZ	DQM<2>	DQM<2>	—	—	Note[19]	Note[19]
W17	DQM<3>	OCZ	DQM<3>	DQM<3>	—	—	Note[19]	Note[19]
V18	NSDCS<0>	OCZ	nSDCS<0>	nSDCS<0>	—	—	Note[19]	Note[19]

**Table 4-4. SCSP Pin Usage Summary (Sheet 4 of 14)**

Ball#	Name	Type	Function After Reset	Primary Function	Secondary Alternate Function	Third Alternate Function	Reset State	Sleep State
R17	NSDCS<1>	OC	nSDCS<1>	nSDCS<1>	—	—	Note[19]	Note[19]
T18	SDCKE	OC	SDCKE	SDCKE	—	—	Note[19]	Note[19]
V20	SDCLK<0>	OC	SDCLK<0>	SDCLK<0>	—	—	Note[19]	Note[19]
P19	SDCLK<1>	OCZ	SDCLK<1>	SDCLK<1>	—	—	Note[19]	Note[19]
T19	SDCLK<2>	OC	SDCLK<2>	SDCLK<2>	—	—	Note[19]	Note[19]
V19	SDCLK<3>	OC	SDCLK<3>	SDCLK<3>	—	—	Note[19]	Note[19]
M4	RDNWR	OCZ	RDnWR	RDnWR	—	—	Note[19]	Note[19]
W1	NCS<0>	OCZ	nCS<0>	nCS<0>	—	—	Note[19]	Note[19]
V1	GPIO<15>	ICOC Z	GPIO<15>	—	—	—	Pu-1 Note[1]	Note[4]
				nPCE<1>	nCS<1> Note[19]	—		
M2	GPIO<18>	ICOC Z	GPIO<18>	RDY	—	—	Pd-0 Note[1]	Note [3]
				—	—	—		
T20	GPIO<20>	ICOC Z	GPIO<20>	DREQ<0>	MBREQ	—	Pu-1 Note[1]	Note[3]
				nSDCS<2> Note[19]	—	—		
R18	GPIO<21>	ICOC Z	GPIO<21>	—	—	—	Pu-1 Note[1]	Note[3]
				nSDCS<3> Note[19]	DVAL<0>	MBGNT		
T3	GPIO<33>	ICOC Z	GPIO<33>	FFRXD	FFDSR	—	Pu-1 Note[1]	Note [4]
				DVAL<1>	nCS<5> Note[19]	MBGNT		
M1	GPIO<49>	ICOC Z	GPIO<49>	—	—	—	Pu-1 Note[1]	Note [5]
				—	nPWE Note[19]	—		
V4	GPIO<78>	ICOC Z	GPIO<78>	—	—	—	Pu-1 Note[1]	Note[4]
				nPCE<2>	nCS<2> Note[19]	—		
P3	GPIO<79>	ICOC Z	GPIO<79>	—	—	—	Pu-1 Note[1]	Note[4]
				PSKTSEL	nCS<3> Note[19]	PWM_OUT<2>		
P1	GPIO<80>	ICOC Z	GPIO<80>	DREQ<1>	MBREQ	—	Pu-1 Note[1]	Note[4]
				—	nCS<4> Note[19]	PWM_OUT<3>		
VCC_BB								
L18	GPIO<48>	ICOC Z	GPIO<48>	CIF_DD<5>	—	—	Pu-1 Note[1]	Note [5]
				BB_OB_DAT<1>	nPOE Note[19]	—		

**Table 4-4. SCSP Pin Usage Summary (Sheet 5 of 14)**

Ball#	Name	Type	Function After Reset	Primary Function	Secondary Alternate Function	Third Alternate Function	Reset State	Sleep State
K17	GPIO<50>	ICOC Z	GPIO<50>	CIF_DD<3>	—	SSPSCCLK<2>	Pu-1 Note[1]	Note [5]
				BB_OB_DAT<2>	nPIOIR Note[19]	SSPSCCLK<2>		
J15	GPIO<51>	ICOC Z	GPIO<51>	CIF_DD<2>	—	—	Pu-1 Note[1]	Note [5]
				BB_OB_DAT<3>	nPIOIW Note[19]	—		
K18	GPIO<52>	ICOC Z	GPIO<52>	CIF_DD<4>	SSPSCCLK<3>	—	Pd-0 Note[1]	Note [3]
				BB_OB_CLK	SSPSCCLK<3>	—		
K19	GPIO<53>	ICOC Z	GPIO<53>	FFRXD	USB_P2_3	—	Pd-0 Note[1]	Note [3]
				BB_OB_STB	CIF_MCLK	SSPSYSCLK		
K20	GPIO<54>	ICOC Z	GPIO<54>	—	BB_OB_WAIT	CIF_PCLK	Pd-0 Note[1]	Note [3]
				—	nPCE<2>	—		
L16	GPIO<55>	ICOC Z	GPIO<55>	CIF_DD<1>	BB_IB_DAT<1>	—	Pu-1 Note[1]	Note [5]
				—	nPREG	—		
M18	GPIO<56>	ICOC Z	GPIO<56>	nPWAIT	BB_IB_DAT<2>	—	Pu-1 Note[1]	Note [5]
				USB_P3_4	—	—		
L17	GPIO<57>	ICOC Z	GPIO<57>	nIOIS16	BB_IB_DAT<3>	—	Pu-1 Note[1]	Note [5]
				—	—	SSPTXD		
K15	GPIO<81>	ICOC Z	GPIO<81>	—	CIF_DD<0>	—	Pu-1 Note[1]	Note [3]
				SSPTXD3	BB_OB_DAT<0>	—		
N19	GPIO<82>	ICOC Z	GPIO<82>	SSPRXD3	BB_IB_DAT<0>	CIF_DD<5>	Pu-1 Note[1]	Note [3]
				—	—	FFDTR		
M19	GPIO<83>	ICOC Z	GPIO<83>	SSPSFRM3	BB_IB_CLK	CIF_DD<4>	Pd-0 Note[1]]	Note [3]
				SSPSFRM3	FFTXD	FFRTS		
M20	GPIO<84>	ICOC Z	GPIO<84>	SSPSCCLK3	BB_IB_STB	CIF_FV	Pd-0 Note[1]	Note [3]
				SSPSCCLK3	—	CIF_FV		
L15	GPIO<85>	ICOC Z	GPIO<85>	FFRXD	DREQ<2>	CIF_LV	Pd-0 Note[1]	Note [3]
				nPCE<1>	BB_IB_WAIT	CIF_LV		
<b>VCC_LCD</b>								
B12	GPIO<14>	ICOC Z	GPIO<14>	L_VSYNC	SSPSFRM2	—	Pd-0 Note[1]	Note [3]
				—	SSPSFRM2	UCLK		
F14	GPIO<19>	ICOC Z	GPIO<19>	SSPSCCLK2	—	FFRXD	Pd-0 Note[1]	Note [3]
				SSPSCCLK2	L_CS	nURST		
D7	GPIO<58>	ICOC Z	GPIO<58>	—	LDD<0>	—	Pd-0 Note[1]	Note [3]
				—	LDD<0>	—		

**Table 4-4. SCSP Pin Usage Summary (Sheet 6 of 14)**

Ball#	Name	Type	Function After Reset	Primary Function	Secondary Alternate Function	Third Alternate Function	Reset State	Sleep State
D8	GPIO<59>	ICOC Z	GPIO<59>	—	LDD<1>	—	Pd-0 Note[1]	Note [3]
				—	LDD<1>	—		
F8	GPIO<60>	ICOC Z	GPIO<60>	—	LDD<2>	—	Pd-0 Note[1]	Note [3]
				—	LDD<2>	—		
A8	GPIO<61>	ICOC Z	GPIO<61>	—	LDD<3>	—	Pd-0 Note[1]	Note [3]
				—	LDD<3>	—		
E8	GPIO<62>	ICOC Z	GPIO<62>	—	LDD<4>	—	Pd-0 Note[1]	Note [3]
				—	LDD<4>	—		
C8	GPIO<63>	ICOC Z	GPIO<63>	—	LDD<5>	—	Pd-0 Note[1]	Note [3]
				—	LDD<5>	—		
C9	GPIO<64>	ICOC Z	GPIO<64>	—	LDD<6>	—	Pd-0 Note[1]	Note [3]
				—	LDD<6>	—		
A9	GPIO<65>	ICOC Z	GPIO<65>	—	LDD<7>	—	Pd-0 Note[1]	Note [3]
				—	LDD<7>	—		
E9	GPIO<66>	ICOC Z	GPIO<66>	—	LDD<8>	—	Pd-0 Note[1]	Note [3]
				—	LDD<8>	—		
F10	GPIO<67>	ICOC Z	GPIO<67>	—	LDD<9>	—	Pd-0 Note[1]	Note [3]
				—	LDD<9>	—		
D10	GPIO<68>	ICOC Z	GPIO<68>	—	LDD<10>	—	Pd-0 Note[1]	Note [3]
				—	LDD<10>	—		
C10	GPIO<69>	ICOC Z	GPIO<69>	—	LDD<11>	—	Pd-0 Note[1]	Note [3]
				—	LDD<11>	—		
B10	GPIO<70>	ICOC Z	GPIO<70>	—	LDD<12>	—	Pd-0 Note[1]	Note [3]
				—	LDD<12>	—		
A10	GPIO<71>	ICOC Z	GPIO<71>	—	LDD<13>	—	Pd-0 Note[1]	Note [3]
				—	LDD<13>	—		
E11	GPIO<72>	ICOC Z	GPIO<72>	—	LDD<14>	—	Pd-0 Note[1]	Note [3]
				—	LDD<14>	—		
F12	GPIO<73>	ICOC Z	GPIO<73>	—	LDD<15>	—	Pd-0 Note[1]	Note [3]
				—	LDD<15>	—		
E13	GPIO<74>	ICOC Z	GPIO<74>	—	—	—	Pd-0 Note[1]	Note [3]
				—	L_FCLK_RD	—		
C12	GPIO<75>	ICOC Z	GPIO<75>	—	—	—	Pd-0 Note[1]	Note [3]
				—	L_LCLK_A0	—		
D12	GPIO<76>	ICOC Z	GPIO<76>	—	—	—	Pd-0 Note[1]	Note [3]
				—	L_PCLK_WR	—		

**Table 4-4. SCSP Pin Usage Summary (Sheet 7 of 14)**

Ball#	Name	Type	Function After Reset	Primary Function	Secondary Alternate Function	Third Alternate Function	Reset State	Sleep State
D13	GPIO<77>	ICOC Z	GPIO<77>	—	—	—	Pd-0 Note[1]	Note [3]
				—	L_BIAS	—		
C11	GPIO<86>	ICOC Z	GPIO<86>	SSPRXD2	LDD<16>	USB_P3_5	Pd-0 Note[1]	Note [3]
				nPCE<1>	LDD<16>	—		
D11	GPIO<87>	ICOC Z	GPIO<87>	nPCE<2>	LDD<17>	USB_P3_1	Pd-0 Note[1]	Note [3]
				SSPTXD2	LDD<17>	SSPSFRM2		
VCC_IO								
J6	GPIO<11>	ICOC Z	GPIO<11>	EXT_SYNC<0>	SSPRXD2	USB_P3_1	Pd-0 Note[1]	Note [3], Note[11]
				CHOUT<0>	PWM_OUT2	48_MHz		
L3	GPIO<12>	ICOC Z	GPIO<12>	EXT_SYNC<1>	CIF_DD<7>	—	Pd-0 Note[1]	Note [3], Note[11]
				CHOUT<1>	PWM_OUT3	48_MHz		
L4	GPIO<13>	ICOC Z	GPIO<13>	CLK_EXT	KP_DKIN<7>	KP_MKIN<7>	Pd-0 Note[1]	Note [3], Note[11]
				SSPTXD2	—	—		
E6	GPIO<16>	ICOC Z	GPIO<16>	KP_MKIN<5>	—	—	Pd-0 Note[1]	Note [3]
				—	PWM_OUT<0>	FFTXD		
G3	GPIO<17>	ICOC Z	GPIO<17>	KP_MKIN<6>	CIF_DD<6>	—	Pd-0 Note[1]	Note [3]
				—	PWM_OUT<1>	—		
F7	GPIO<22>	ICOC Z	GPIO<22>	SSPEXTCLK2	SSPCLKEN2	SSPCLK2	Pd-0 Note[1]	Note [3]
				KP_MKOUT<7>	SSPSYSCLK2	SSPCLK2		
H1	GPIO<23>	ICOC Z	GPIO<23>	—	SSPCLK	—	Pd-0 Note[1]	Note [3]
				CIF_MCLK	SSPCLK	—		
H2	GPIO<24>	ICOC Z	GPIO<24>	CIF_FV	SSPSFRM	—	Pd-0 Note[1]	Note [3]
				CIF_FV	SSPSFRM	—		
F6	GPIO<25>	ICOC Z	GPIO<25>	CIF_LV	—	—	Pd-0 Note[1]	Note [3]
				CIF_LV	SSPTXD	—		
H3	GPIO<26>	ICOC Z	GPIO<26>	SSPRXD	CIF_PCLK	FFCTS	Pd-0 Note[1]	Note [3]
				—	—	—		
H4	GPIO<27>	ICOC Z	GPIO<27>	SSPEXTCLK	SSPCLKEN	CIF_DD<0>	Pd-0 Note[1]	Note [3]
				SSPSYSCLK	—	FFRTS		
K1	GPIO<28>	ICOC Z	GPIO<28>	AC97_BITCLK	I2S_BITCLK	SSPSFRM	Pd-0 Note[1]	Note [3]
				I2S_BITCLK	—	SSPSFRM		
K2	GPIO<29>	ICOC Z	GPIO<29>	AC97_SDATA_IN_0	I2S_SDATA_IN	SSPCLK	Pd-0 Note[1]	Note [3]
				SSPRXD2	—	SSPCLK		
G6	GPIO<30>	ICOC Z	GPIO<30>	—	—	—	Pd-0 Note[1]	Note [3]
				I2S_SDATA_OUT	AC97_SDATA_OUT	USB_P3_2		

Table 4-4. SCSP Pin Usage Summary (Sheet 8 of 14)

Ball#	Name	Type	Function After Reset	Primary Function	Secondary Alternate Function	Third Alternate Function	Reset State	Sleep State
J4	GPIO<31>	ICOC Z	GPIO<31>	—	—	—	Pd-0 Note[1]	Note [3]
				I2S_SYNC	AC97_SYNC	USB_P3_6		
F3	GPIO<32>	ICOC Z	GPIO<32>	—	—	—	Pd-0 Note[1]	Note [3]
				MSSCLK	MMCLK	—		
F2	GPIO<34>	ICOC Z	GPIO<34>	FFRXD	KP_MKIN<3>	SSPSCLK3	Pd-0 Note[1]	Note [3]
				USB_P2_2	—	SSPSCLK3		
E3	GPIO<35>	ICOC Z	GPIO<35>	FFCTS	USB_P2_1	SSPSFRM3	Pd-0 Note[1]	Note [3]
				—	KP_MKOUT<6>	SSPTXD3		
G4	GPIO<36>	ICOC Z	GPIO<36>	FFDCD	SSPSCLK2	KP_MKIN<7>	Pd-0 Note[1]	Note [3]
				USB_P2_4	SSPSCLK2	—		
G5	GPIO<37>	ICOC Z	GPIO<37>	FFDSR	SSPSFRM2	KP_MKIN<3>	Pd-0 Note[1]	Note [3]
				USB_P2_8	SSPSFRM2	FFTXD		
H5	GPIO<38>	ICOC Z	GPIO<38>	FFRI	KP_MKIN<4>	USB_P2_3	Pd-0 Note[1]	Note [3]
				SSPTXD3	SSPTXD2	PWM_OUT<1>		
D4	GPIO<39>	ICOC Z	GPIO<39>	KP_MKIN<4>	—	SSPSFRM3	Pd-0 Note[1]	Note [3]
				USB_P2_6	FFTXD	SSPSFRM3		
J3	GPIO<40>	ICOC Z	GPIO<40>	SSPRXD2	—	USB_P2_5	Pd-0 Note[1]	Note [3]
				KP_MKOUT<6>	FFDTR	SSPSCLK3		
D5	GPIO<41>	ICOC Z	GPIO<41>	FFRXD	USB_P2_7	SSPRXD3	Pd-0 Note[1]	Note [3]
				KP_MKOUT<7>	FFRTS	—		
A4	GPIO<42>	ICOC Z	GPIO<42>	BTRXD	ICP_RXD	—	Pd-0 Note[1]	Note [3]
				—	—	CIF_MCLK		
B4	GPIO<43>	ICOC Z	GPIO<43>	—	—	CIF_FV	Pd-0 Note[1]	Note [3]
				ICP_TXD	BTTXD	CIF_FV		
D3	GPIO<44>	ICOC Z	GPIO<44>	BTCTS	—	CIF_LV	Pd-0 Note[1]	Note [3]
				—	—	CIF_LV		
F1	GPIO<45>	ICOC Z	GPIO<45>	—	—	CIF_PCLK	Pd-0 Note[1]	Note [3]
				AC97_SYSCLK	BTRTS	SSPSYSCLK3		
H6	GPIO<46>	ICOC Z	GPIO<46>	ICP_RXD	STD_RXD	—	Pd-0 Note[1]	Note [3]
				—	PWM_OUT<2>	—		
K5	GPIO<47>	ICOC Z	GPIO<47>	CIF_DD<0>	—	—	Pd-0 Note[1]	Note [3]
				STD_TXD	ICP_TXD	PWM_OUT<3>		



**Table 4-4. SCSP Pin Usage Summary (Sheet 9 of 14)**

Ball#	Name	Type	Function After Reset	Primary Function	Secondary Alternate Function	Third Alternate Function	Reset State	Sleep State
B3	GPIO<88>	ICOC Z	GPIO<88>	USBHPWR<1>	SSPRXD2	SSPSFRM2	Pd-0 Note[1]	Note [3]
				—	—	SSPSFRM2		
A3	GPIO<89>	ICOC Z	GPIO<89>	SSPRXD3	—	FFRI	Pd-0 Note[1]	Note [3]
				AC97_SYSCLK	USBHPEN<1>	SSPTXD2		
G2	GPIO<92>	ICOC Z	GPIO<92>	MMDAT<0>	—	—	Pd-0 Note[1]	Note [3]
				MMDAT<0>	MSBS	—		
G19	GPIO<93>	ICOC Z	GPIO<93>	KP_DKIN<0>	CIF_DD<6>	—	Pd-0 Note[1]	Note [3]
				AC97_SDATA_OUT	—	—		
F16	GPIO<94>	ICOC Z	GPIO<94>	KP_DKIN<1>	CIF_DD<5>	—	Pd-0 Note[1]	Note [3]
				AC97_SYNC	—	—		
G20	GPIO<95>	ICOC Z	GPIO<95>	KP_DKIN<2>	CIF_DD<4>	KP_MKIN<6>	Pd-0 Note[1]	Note [3]
				AC97_RESET_n	—	—		
F17	GPIO<96>	ICOC Z	GPIO<96>	KP_DKIN<3>	MBREQ	FFRXD	Pd-0 Note[1]	Note [3]
				—	DVAL<1>	KP_MKOUT<6>		
F15	GPIO<97>	ICOC Z	GPIO<97>	KP_DKIN<4>	DREQ<1>	KP_MKIN<3>	Pd-0 Note[1]	Note [3]
				—	MBGNT	—		
G18	GPIO<98>	ICOC Z	GPIO<98>	KP_DKIN<5>	CIF_DD<0>	KP_MKIN<4>	Pd-0	Note [3]
				AC97_SYSCLK	—	FFRTS		
G17	GPIO<99>	ICOC Z	GPIO<99>	KP_DKIN<6>	AC97_SDATA_IN_1	KP_MKIN<5>	Pd-0	Note [3]
				—	—	FFTXD		
G16	GPIO<100>	ICOC Z	GPIO<100>	KP_MKIN<0>	DREQ<2>	FFCTS	Pd-0 Note[1]	Note [3]
				—	—	—		
H18	GPIO<101>	ICOC Z	GPIO<101>	KP_MKIN<1>	—	—	Pd-0 Note[1]	Note [3]
				—	—	—		
H19	GPIO<102>	ICOC Z	GPIO<102>	KP_MKIN<2>	—	FFRXD	Pd-0 Note[1]	Note [3]
				nPCE<1>	—	—		
J20	GPIO<103>	ICOC Z	GPIO<103>	CIF_DD<3>	—	—	Pd-0 Note[1]	Note [3]
				—	KP_MKOUT<0>	—		
H17	GPIO<104>	ICOC Z	GPIO<104>	CIF_DD<2>	—	—	Pd-0 Note[1]	Note [3]
				PSKTSEL	KP_MKOUT<1>	—		
J18	GPIO<105>	ICOC Z	GPIO<105>	CIF_DD<1>	—	—	Pd-0 Note[1]	Note [3]
				nPCE<2>	KP_MKOUT<2>	—		

**Table 4-4. SCSP Pin Usage Summary (Sheet 10 of 14)**

Ball#	Name	Type	Function After Reset	Primary Function	Secondary Alternate Function	Third Alternate Function	Reset State	Sleep State
H16	GPIO<106>	ICOC Z	GPIO<106>	CIF_DD<9>	—	—	Pd-0 Note[1]	Note [3]
				—	KP_MKOUT<3>	—		
J17	GPIO<107>	ICOC Z	GPIO<107>	CIF_DD<8>	—	—	Pd-0 Note[1]	Note [3]
				—	KP_MKOUT<4>	—		
J16	GPIO<108>	ICOC Z	GPIO<108>	CIF_DD<7>	—	—	Pd-0 Note[1]	Note [3]
				CHOUT<0>	KP_MKOUT<5>	—		
E5	GPIO<109>	ICOC Z	GPIO<109>	MMDAT<1>	MSSDIO	—	Pd-0 Note[1]	Note [3]
				MMDAT<1>	MSSDIO	—		
F4	GPIO<110>	ICOC Z	GPIO<110>	MMDAT<2>/ MMCCS<0>	—	—	Pd-0 Note[1]	Note [3]
				MMDAT<2>/ MMCCS<0>	—	—		
F5	GPIO<111>	ICOC Z	GPIO<111>	MMDAT<3>/ MMCCS<1>	—	—	Pd-0 Note[1]	Note [3]
				MMDAT<3>/ MMCCS<1>	—	—		
G1	GPIO<112>	ICOC Z	GPIO<112>	MMCMD	nMSINS	—	Pd-0 Note[1]	Note [3]
				MMCMD	—	—		
K4	GPIO<113>	ICOC Z	GPIO<113>	—	—	USB_P3_3	Pd-0 Note[1]	Note [3]
				I2S_SYSCCLK	AC97_RESET_n	—		
C5	GPIO<114> Note [17]	ICOC Z	GPIO<114> Note [17]	CIFDD_<1>	—	—	Pd-0 Note[1]	Note [3]
				—	UVS0	—		
B5	GPIO<115> Note [17]	ICOC Z	GPIO<115> Note [17]	DREQ<0>	CIF_DD<3>	MBREQ	Pu-1 Note[1]	Note [3]
				UEN	nUVS1	PWM_OUT< 1>		
C4	GPIO<116>	ICOC Z	GPIO<116>	CIF_DD<2>	AC97_SDATA_IN_0	UDET	Pu-1 Note[1]	Note [3]
				DVAL<0>	nUVS2	MBGNT		
E2	GPIO<117>	ICOC Z	GPIO<117>	SCL	—	—	Pu-1 Note[1]	Note [3], Note[12]
				SCL	—	—		
B1	GPIO<118>	ICOC Z	GPIO<118>	SDA	—	—	Pu-1 Note[1]	Note [3], Note[12]
				SDA	—	—		
B2	GPIO<119>	ICOC Z	GPIO<119>	USBHPWR<2>	—	—	Pd-0 Note[1]	Note [3]
				—	—	—		
C3	GPIO<120>	ICOC Z	GPIO<120>	—	—	—	Pd-0 Note[1]	Note [3]
				—	USBHPEN<2>	—		
VCC_USB								
D2	USBC_P	IAOAZ	USBC_P	USBC_P	—	—	Hi-Z	Hi-Z
C2	USBC_N	IAOAZ	USBC_N	USBC_N	—	—	Hi-Z	Hi-Z

**Table 4-4. SCSP Pin Usage Summary (Sheet 11 of 14)**

Ball#	Name	Type	Function After Reset	Primary Function	Secondary Alternate Function	Third Alternate Function	Reset State	Sleep State
A6	USBH_P<1>	IAOAZ	USBH_P<1>	USBH_P<1>	—	—	Hi-Z	Hi-Z
A5	USBH_N<1>	IAOAZ	USBH_N<1>	USBH_N<1>	—	—	Hi-Z	Hi-Z
<b>VCC_USIM</b>								
A7	GPIO<90>	ICOC Z	GPIO<90>	KP_MKIN<5>	USB_P3_5	CIF_DD<4>	Pd-0 Note[1]	Note [3]
				—	nURST	—		
C7	GPIO<91>	ICOC Z	GPIO<91>	KP_MKIN<6>	USB_P3_1	CIF_DD<5>	Pd-0 Note[1]	Note [3]
				—	UCLK	—		
B6	UIO	ICOC Z	UIO	UIO	—	—	Driven Low	Hi-Z
<b>VCC_REG</b>								
A15	GPIO<0>	ICOC Z	GPIO<0>	GPIO<0>	—	—	Pd-0 Note[1]	Note [3]
D16	GPIO<1>	ICOC Z	GPIO<1>	GPIO<1>	—	—	Pu-1 Note[1]	Note [7]
C16	GPIO<3>	ICOC Z	GPIO<3>	PWR_SCL	—	—	Pu-1 Note[1]	Hi-Z
B15	GPIO<4>	ICOC Z	GPIO<4>	PWR_SDA	—	—	Pu-1 Note[1]	Hi-Z
A14	GPIO<9> Note [18]	ICOC Z	GPIO<9> Note [18]	—	—	FFCTS	Pd-0 Note[1]	Note [7,18]
				HZ_CLK	—	CHOUT<0>		
D15	GPIO<10> Note [18]	ICOC Z	GPIO<10> Note [18]	FFDCD	—	USB_P3_5	Pd-0 Note[1]	Note [7,18]
				HZ_CLK	—	CHOUT<1>		
E15	CLK_REQ	ICOC Z	CLK_REQ	CLK_REQ	—	—	Pu-1	Note [8]
A16	NRESET	IC	nRESET	nRESET	—	—	Input - Note [9]	Input
B19	NRESET_OUT	OC	nRESET_OUT	nRESET_OUT	—	—	Low	Note [8]
B18	BOOT_SEL	IC	BOOT_SEL	BOOT_SEL	—	—	Input	Input
B16	PWR_EN	OC	PWR_EN	PWR_EN	—	—	Note[16]	Note [8]
C18	NBATT_FAULT	IC	nBATT_FAULT	nBATT_FAULT	—	—	Low	Input
C17	NVDD_FAULT	IC	nVDD_FAULT	nVDD_FAULT	—	—	Low	Input
D17	SYS_EN	ICOC Z	SYS_EN	SYS_EN	—	—	Pu-1 Note[1]	Note [7]
C19	PWR_CAP<0>	OA	—	PWR_CAP<0>	—	—	Pd-0 Note[1]	Note [7]
D18	PWR_CAP<1>	OA	—	PWR_CAP<1>	—	—	Pd-0 Note[1]	Note [7]
E18	PWR_CAP<2>	OA	—	PWR_CAP<2>	—	—	Pd-0 Note[1]	Note [7]

**Table 4-4. SCSP Pin Usage Summary (Sheet 12 of 14)**

Ball#	Name	Type	Function After Reset	Primary Function	Secondary Alternate Function	Third Alternate Function	Reset State	Sleep State
E16	PWR_CAP<3>	OA	—	PWR_CAP<3>	—	—	Pu-1 Note[1]	Note [7]
C14	NTRST	IC	nTRST	nTRST	—	—	Input - Note [9]	Input
B14	TDI	IC	TDI	TDI	—	—	Input - Note [9]	Input
D14	TDO	OCZ	TDO	TDO	—	—	Hi-Z	Hi-Z
C13	TMS	IC	TMS	TMS	—	—	Input - Note [9]	Input
E14	TCK	IC	TCK	TCK	—	—	Input	Input
A13	TESTCLK	IC	TESTCLK	TESTCLK	—	—	Pd-0	Input
<b>VCC_OSC</b>								
E19	PXTAL_IN	IA	PXTAL_IN	PXTAL_IN	—	—	Note[2]	Note [2]
E20	PXTAL_OUT	OA	PXTAL_OUT	PXTAL_OUT	—	—	Note[2]	Note [2]
B17	TXTAL_IN	IA	TXTAL_IN	TXTAL_IN	—	—	Note[2]	Note [2]
A17	TXTAL_OUT	OA	TXTAL_OUT	TXTAL_OUT	—	—	Note[2]	Note [2]
D20	PWR_OUT	OA	PWR_OUT	PWR_OUT	—	—	Hi-Z	Hi-Z
<b>VCC_SUP</b>								
E17	VCC_BATT	PS	VCC_BATT	VCC_BATT	—	—	Input	Input
H20	VCC_IO	PS	VCC_IO	VCC_IO	—	—	Input	Input
J1	VCC_IO	PS	VCC_IO	VCC_IO	—	—	Input	Input
L1	VCC_IO	PS	VCC_IO	VCC_IO	—	—	Input	Input
A1	VCC_USB	PS	VCC_USB	VCC_USB	—	—	Input	Input
A2	VCC_USB	PS	VCC_USB	VCC_USB	—	—	Input	Input
D1	VCC_USB	PS	VCC_USB	VCC_USB	—	—	Input	Input
A11	VCC_LCD	PS	VCC_LCD0	VCC_LCD	—	—	Input	Input
B8	VCC_LCD	PS	VCC_LCD	VCC_LCD	—	—	Input	Input
notes1	VCC_MEM	PS	VCC_MEM	VCC_MEM	—	—	Input	Input
L20	VCC_BB	PS	VCC_BB	VCC_BB	—	—	Input	Input
F18	VCC_PLL	PS	VCC_PLL	VCC_PLL	—	—	Input	Input
M3	VCC_SRAM	PS	VCC_SRAM	VCC_SRAM	—	—	Input	Input
N3	VCC_SRAM	PS	VCC_SRAM	VCC_SRAM	—	—	Input	Input
R3	VCC_SRAM	PS	VCC_SRAM	VCC_SRAM	—	—	Input	Input
U3	VCC_SRAM	PS	VCC_SRAM	VCC_SRAM	—	—	Input	Input
A12	VCC_CORE	PS	VCC_CORE	VCC_CORE	—	—	Input	Input
B7	VCC_CORE	PS	VCC_CORE	VCC_CORE	—	—	Input	Input
B9	VCC_CORE	PS	VCC_CORE	VCC_CORE	—	—	Input	Input
B11	VCC_CORE	PS	VCC_CORE	VCC_CORE	—	—	Input	Input

**Table 4-4. SCSP Pin Usage Summary (Sheet 13 of 14)**

Ball#	Name	Type	Function After Reset	Primary Function	Secondary Alternate Function	Third Alternate Function	Reset State	Sleep State
E1	VCC_CORE	PS	VCC_CORE	VCC_CORE	—	—	Input	Input
J19	VCC_CORE	PS	VCC_CORE	VCC_CORE	—	—	Input	Input
K3	VCC_CORE	PS	VCC_CORE	VCC_CORE	—	—	Input	Input
L19	VCC_CORE	PS	VCC_CORE	VCC_CORE	—	—	Input	Input
R2	VCC_CORE	PS	VCC_CORE	VCC_CORE	—	—	Input	Input
R20	VCC_CORE	PS	VCC_CORE	VCC_CORE	—	—	Input	Input
T13	VCC_CORE	PS	VCC_CORE	VCC_CORE	—	—	Input	Input
T15	VCC_CORE	PS	VCC_CORE	VCC_CORE	—	—	Input	Input
U1	VCC_CORE	PS	VCC_CORE	VCC_CORE	—	—	Input	Input
C6	VCC_USIM	PS	VCC_USIM	VCC_USIM	—	—	Input	Input
notes2	VSS	PS	VSS	VSS	—	—	Input	Input
D6	VSS_IO	PS	VSS_IO	VSS_IO	—	—	Input	Input
D9	VSS_IO	PS	VSS_IO	VSS_IO	—	—	Input	Input
E4	VSS_IO	PS	VSS_IO	VSS_IO	—	—	Input	Input
E12	VSS_IO	PS	VSS_IO	VSS_IO	—	—	Input	Input
F20	VSS_IO	PS	VSS_IO	VSS_IO	—	—	Input	Input
G15	VSS_IO	PS	VSS_IO	VSS_IO	—	—	Input	Input
J2	VSS_IO	PS	VSS_IO	VSS_IO	—	—	Input	Input
L2	VSS_IO	PS	VSS_IO	VSS_IO	—	—	Input	Input
B13	VSS_IO	PS	VSS_IO	VSS_IO	—	—	Input	Input
notes3	VSS_MEM	PS	VSS_MEM	VSS_MEM	—	—	Input	Input
K16	VSS_BB	PS	VSS_BB	VSS_BB	—	—	Input	Input
F19	VSS_PLL	PS	VSS_PLL	VSS_PLL	—	—	Input	Input
R13	VSS_CORE	PS	VSS_CORE	VSS_CORE	—	—	Input	Input
R16	VSS_CORE	PS	VSS_CORE	VSS_CORE	—	—	Input	Input
U2	VSS_CORE	PS	VSS_CORE	VSS_CORE	—	—	Input	Input
U4	VSS_CORE	PS	VSS_CORE	VSS_CORE	—	—	Input	Input
U18	VSS_CORE	PS	VSS_CORE	VSS_CORE	—	—	Input	Input
V3	VSS_CORE	PS	VSS_CORE	VSS_CORE	—	—	Input	Input
Y1	VSS_CORE	PS	VSS_CORE	VSS_CORE	—	—	Input	Input
C1	VSS_CORE	PS	VSS_CORE	VSS_CORE	—	—	Input	Input
E7	VSS_CORE	PS	VSS_CORE	VSS_CORE	—	—	Input	Input
E10	VSS_CORE	PS	VSS_CORE	VSS_CORE	—	—	Input	Input
F9	VSS_CORE	PS	VSS_CORE	VSS_CORE	—	—	Input	Input
F11	VSS_CORE	PS	VSS_CORE	VSS_CORE	—	—	Input	Input
F13	VSS_CORE	PS	VSS_CORE	VSS_CORE	—	—	Input	Input



**Table 4-4. SCSP Pin Usage Summary (Sheet 14 of 14)**

Ball#	Name	Type	Function After Reset	Primary Function	Secondary Alternate Function	Third Alternate Function	Reset State	Sleep State
H15	VSS_CORE	PS	VSS_CORE	VSS_CORE	—	—	Input	Input
J5	VSS_CORE	PS	VSS_CORE	VSS_CORE	—	—	Input	Input
K6	VSS_CORE	PS	VSS_CORE	VSS_CORE	—	—	Input	Input
N4	VSS_CORE	PS	VSS_CORE	VSS_CORE	—	—	Input	Input

**NOTES:**  
1. 2. 3. Refer to PXA27x Processor Mapping Table for VCC\_MEM, VSS\_MEM and VSS ball location



## 4.5 Signal Types

**Table 4-5. Pin Usage and Mapping Notes**

Note	Description
[1]	<i>GPIO reset/deep sleep operation:</i> After any reset is asserted or if the Intel PXA27x processor is in deep sleep mode, these pins are configured as GPIO inputs by default. The input buffers for these pins are disabled to prevent current drain and must be enabled prior to use by clearing the <i>read disable hold</i> bit, PSSR[RDH]. Until RDH is cleared, each pin is pulled high (Pu-1), pulled low (Pd-0), or floated (Hi-Z).
[2]	<i>Crystal oscillator pins:</i> These pins connect the external crystals to the on-chip oscillators and are not affected by either reset or sleep. For more information, see the "Clocks and Power" chapter in the <i>Intel® PXA27x Processor Family Developer's Manual</i> .
[3]	<i>GPIO sleep operation:</i> During the transition into sleep mode, the configuration of these pins is determined by the corresponding GPIO setting. This pin is not driven during sleep if the direction of the pin is selected to be an input. If the direction of the pin is selected as an output, the value contained in the Power Manager GPIO Sleep-State register (PGSR0/1/2/3) is driven out onto the pin and held while the pin is in sleep mode. Upon exit from sleep mode, GPIOs that are configured as outputs continue to hold the standby, sleep, or deep-sleep state until software clears the peripheral control hold bit, PSSR[PH]. Software must clear this bit (by writing 0b1 to it) after the peripherals have been fully configured, as described in Note[1], but before the process actually uses them. GPIOs that are configured as inputs immediately after exiting sleep mode cannot be used until PSSR[RDH] is cleared.
[4]	<i>Static memory control pins:</i> During sleep mode, these pins can be programmed either to drive the value in the Power Manager GPIO Sleep-State register (PGSR0/1/2/3) or to be placed in a Hi-Z (undriven) state. To select the Hi-Z state, software must set PCFR[FS]. If FS is not set, these pins function as described in Note[3] during the transition to sleep mode.
[5]	<i>PCMCIA control pins:</i> During sleep mode, these pins can be programmed either to drive the value in the Power Manager GPIO Sleep-State register (PGSR0/1/2/3) or to be placed in a Hi-Z (undriven) state. To select the Hi-Z state, software must set PCFR[FP]. If FP is not set, these pins function as described in Note[3] during the transition to sleep mode.
[6]	(reserved)
[7]	When the power manager overrides the GPIO alternate function, the Power Manager GPIO Sleep-State registers (PGSR0/1/2/3) and the PSSR[RDH] bit are ignored. Pullup and pulldown are disabled immediately after the power manager overrides the GPIO function.
[8]	Output functions during sleep mode
[9]	Pull-up always enabled
[10]	(reserved)
[11]	Pins do not function during sleep mode if the OS timer is active
[12]	Pins must be floated by software during sleep mode (floating does not happen automatically)
[13]	(reserved)
[14]	(reserved)
[15]	The pin is three-stateable (Hi-Z) based on the value of PCFR[FS]. There is no PGSR0/1/2/3 setting associated with the pin because it is not a GPIO.
[16]	PWR_EN goes high during reset, between the assertion of the reset pin and the de-assertion of internal reset within the Intel PXA27x processor, after SYS_EN is driven high.
[17]	<i>GPIOs 114 and 115:</i> The alternate function configuration of these pins is ignored when either PUCR[USIM114] or PUCR[USIM115] bits are set. Setting these bits forces the USIM enable signal onto these GPIOs.
[18]	When software sets the OSCC[PIO_EN] or OSCC[TOUT_EN] bits, then any GPIO alternate function setting applied to GPIO<9> or GPIO <10> is overridden with the CLK_PIO function on GPIO<9> and CLK_TOUT on GPIO<10>.
[19]	Refer to <a href="#">Table 4-7</a> .

**Table 4-6. Signal Types**

Type	Description
IC	CMOS input
OC	CMOS output
OCZ	CMOS output, three-stateable
ICOCZ	CMOS bidirectional, three-stateable
IA	Analog input
OA	Analog output
IAOA	Analog bidirectional
IAOAZ	Analog bidirectional - three-stateable
PS	Power supply

## 4.6 Memory Controller Reset and Initialization

On reset, the SDRAM interface is disabled. Reset values for the boot ROM are determined by BOOT\_SEL (see the *Intel® PXA27x Processor Family Developers Manual*, Memory Controller chapter). Boot ROM is immediately available for reading upon exit from reset, and all memory interface control registers are available for writing.

On hardware reset, the memory pins and controller are in the state shown in [Table 4-7](#).

**Table 4-7. Memory Controller Pin Reset Values (Sheet 1 of 2)**

Pin Name	Reset, Sleep, Standby, Deep-Sleep, Frequency Change, and Manual Self-Refresh Mode Values
SDCLK <3 <sup>1</sup> :0>	0b000
SDCKE	0
DQM <3:0>	0b0000
nSDCS <3:2>	GPIO (memory controller drives 0b11) <sup>†</sup>
nSDCS <1:0>	0b11
nWE	1
nSDRAS	1
nSDCAS	1
nOE	1
MA <25:0>	0x0000_0000 <sup>1</sup>
RDnWR	0
MD <31:0>	0x0000_0000 <sup>2</sup>
nCS <0>	1
nCS <5:1>	GPIO (memory controller drives 0b11111)
nPIOIR	GPIO (memory controller drives high)
nPIOIW	GPIO (memory controller drives high)



**Table 4-7. Memory Controller Pin Reset Values (Sheet 2 of 2)**

Pin Name	Reset, Sleep, Standby, Deep-Sleep, Frequency Change, and Manual Self-Refresh Mode Values
nPOE	GPIO (memory controller drives high)
nPWE	GPIO (memory controller drives high)
<b>NOTE:</b> † This indicates that the GPIO pin, if configured for the alternate function used by the memory controller during reset, drives the represented value. <b>NOTE:</b> SCLK<3> is only available on PXA27x processor family packages 1. MA pins are driven 2. MD pins are pulled low	

The address signals are driven low and data signals are pulled low during sleep, standby, deep-sleep, frequency-change modes, and manual self-refresh. All other memory control signals are in the same state that they are in after a hardware reset. If the SDRAMs are in self-refresh mode, they are kept there by driving SDCKE low.

## 4.7 Power-Supply Pins

Table 4-8 summarizes the power-supply ball count.

**Table 4-8. SCSP 1.8V Power Supply Pin Summary**

Name	Number of Package Balls
VCC_BATT	1
VCC_IO	3
VCC_USB	3
VCC_LCD	2
VCC_MEM	24
VCC_BB	1
VCC_PLL	1
VCC_SRAM	4
VCC_CORE	13
VCC_USIM	1
VSS	7
VSS_IO	9
VSS_MEM	19
VSS_BB	1
VSS_PLL	1
VSS_CORE	17

§§





# Electrical Specifications

# 5

## 5.1 Absolute Maximum Ratings

The absolute maximum ratings (shown in Table 5-1) define limitations for electrical and thermal stresses. These limits prevent permanent damage to the Intel® PXA27x Processor Family (PXA27x processor).

**Note:** Absolute maximum ratings are not operating ranges.

**Table 5-1. Absolute Maximum Ratings**

Symbol	Description	Min	Max	Units
$T_S$	Storage temperature	-40	125	°C
$V_{CC\_OL1}$	Offset voltage between any of the following pins: VCC_CORE	-0.3	0.3	V
$V_{CC\_OL2}$	Offset voltage between any of the following pins: VCC_SRAM	-0.3	0.3	V
$V_{CC\_OH1}$	Offset voltage between any of the following pins: VCC_MEM	-0.3	0.3	V
$V_{CC\_OH2}$	Offset voltage between any of the following pins: VCC_IO	-0.3	0.3	V
$V_{CC\_OH3}$	Offset voltage between VCC_LCD<0> and VCC_LCD<1>	-0.3	0.3	V
$V_{CC\_HV}$	Voltage applied to high-voltage supply pins (VCC_BB, VCC_USIM, VCC_MEM, VCC_IO<, VCC_LCD)	VSS-0.3	VSS+4.0	V
$V_{CC\_LV}$	Voltage applied to low-voltage supply pins (VCC_CORE, VCC_PLL, VCC_SRAM)	VSS-0.3	VSS+1.45	V
$V_{IP}$	Voltage applied to non-supply pins except PXTAL_IN, PXTAL_OUT, TXTAL_IN, and TXTAL_OUT pins	VSS-0.3	VSS+4.0	V
$V_{IP\_X}$	Voltage applied to XTAL pins (PXTAL_IN, PXTAL_OUT, TXTAL_IN, TXTAL_OUT)	VSS-0.3	VSS+1.45	V
$V_{ESD}$	Maximum ESD stress voltage, three stresses maximum: <ul style="list-style-type: none"> <li>Any pin to any supply pin, either polarity, or</li> <li>Any pin to all non-supply pins together, either polarity</li> </ul>	—	2000	V
$I_{EOS}$	Maximum DC input current (electrical overstress) for any non-supply pin	—	5	mA

## 5.2 Operating Conditions

This section shows operating voltage, frequency, and temperature specifications for the PXA27x processor.

Table 5-2 shows each power domains supported voltages (except for VCC\_MEM and VCC\_CORE). Table 5-3 shows all of the supported memory voltages and frequency operating ranges (VCC\_MEM). Table Note: shows all of the supported core voltage and frequency ranges (VCC\_CORE).

The operating temperature specification is a function of voltage and frequency.

**Table 5-2. Voltage, Temperature, and Frequency Electrical Specifications (Sheet 1 of 2)**

Symbol	Description	Min	Typical	Max	Units
<b>Operating Temperature</b>					
Tcase	Package operating temperature <sup>†</sup>	-25	—	+85	°C
Theta Jc	Junction-to-case temperature gradient	—	2	—	°C / watt
<b>VCC_BATT Voltage</b>					
VVCC0	Voltage applied on VCC_BATT @3.0V	2.25	3.00	3.75	V
VVDF1	Voltage difference between VCC_BATT and VCC_IO during power-on reset or deep-sleep wake-up (from the assertion of SYS_EN to the de-assertion of nRESET_OUT)	0	—	0.30	V
VVDF2	Voltage difference between VCC_BATT and VCC_IO when VCC_IO is enabled	0	—	0.20	V
Tbramp	Ramp Rate	—	10	8	mV/uS
<b>VCC_PLL Voltage</b>					
VVCC1	Voltage applied on VCC_PLL @1.3V (+10 / -10%)	1.17	1.30	1.43	V
Tpwrramp	Ramp Rate	—	10	8	mV/uS
<b>VCC_BB Voltages</b>					
VVCC2a	Voltage applied on VCC_BB @1.8V (+20 / -5%)	1.71	1.80	2.16	V
VVCC2b	Voltage applied on VCC_BB @2.5V (+10 / -10%)	2.25	2.50	2.75	V
VVCC2c	Voltage applied on VCC_BB @3.0V (+10 / -10%)	2.70	3.0	3.30	V
VVCC2d	Voltage applied on VCC_BB @3.3V (+10 / -10%)	2.97	3.3	3.63	V
Tsysramp	Ramp Rate	—	10	8	mV/uS
<b>VCC_LCD Voltages</b>					
VVCC3a	Voltage applied on VCC_LCD @1.8V (+20 / -5%)	1.71	1.80	2.16	V
VVCC3b	Voltage applied on VCC_LCD @2.5V (+10 / -10%)	2.25	2.50	2.75	V
VVCC3c	Voltage applied on VCC_LCD @3.0V (+10 / -10%)	2.70	3.0	3.30	V
VVCC3d	Voltage applied on VCC_LCD @3.3V (+10 / -10%)	2.97	3.3	3.63	V

**Table 5-2. Voltage, Temperature, and Frequency Electrical Specifications (Sheet 2 of 2)**

Symbol	Description	Min	Typical	Max	Units
Tsysramp	Ramp Rate	—	10	8	mV/uS
<b>VCC_IO Voltages</b>					
VVCC4a	Voltage applied on VCC_IO @3.0V (+10 / -10.3%)	2.69175	3.0	3.30	V
VVCC4b	Voltage applied on VCC_IO @3.3V (+10 / -10%)	2.97	3.3	3.63	V
Tsysramp	Ramp Rate	—	10	8	mV/uS
<b>NOTE:</b> VCC_IO must be maintained at a voltage as high as or higher than, all other supplies except for VCC_BATT and VCC_USB					
<b>VCC_USIM Voltages</b>					
VVCC5a	Voltage applied on VCC_USIM @1.8V (+20 / -5%)	1.71	1.80	2.16	V
VVCC5b	Voltage applied on VCC_USIM @3.0V (+10 / -10%)	2.70	3.0	3.30	V
Tsysramp	Ramp Rate	—	10	8	mV/uS
<b>NOTE:</b> If the system does NOT use the USIM module, VCC_USIM can be tied to VCC_IO (at any supported VCC_IO voltage level). This allows the GPIO's on VCC_USIM to be used at the same voltage level as VCC_IO GPIO's. <b>NOTE:</b> Software must NOT configure USIM signals to be used if this is done.					
<b>VCC_SRAM Voltage</b>					
VVCC6	Voltage applied on VCC_SRAM @1.1V (+10 / -10%)	0.99	1.10	1.21	V
Tpwrramp	Ramp Rate	—	10	8	mV/uS
<b>VCC_USB Voltage</b>					
VVCC7a	Voltage applied on VCC_USB @3.0V (+10 / -10%)	2.70	3.00	3.30	V
VVCC7b	Voltage applied on VCC_USB @3.3V (+10 / -10%)	2.97	3.30	3.63	V
Tsysramp	Ramp Rate	—	10	8	mV/uS
† System design must ensure that the device case temperature is maintained within the specified limits. In some system applications it may be necessary to use external thermal management (for example, a package-mounted heat spreader) or configure the device to limit power consumption and maintain acceptable case temperatures.					

Table 5-3 shows the supported memory frequency and memory supply voltage operating ranges for the Intel PXA27x processor.

**Note:** Do not exceed top package specifications. Refer to the appropriate top package data sheets for top package specifications.

**Table 5-3. Memory Voltage and Frequency Electrical Specifications**

Symbol	Description	Min	Typical	Max	Units
<b>Memory Voltage and Frequency Range:</b>					
VMEM1	Voltage applied on VCC_MEM	1.71	1.80	2.16	V

fSM1A	External synchronous memory frequency, SDCLK1, SDCLK2	13	—	104	MHz
fSM1Ba	External synchronous memory frequency, SDCLK0	13	—	104	MHz
Tsysramp	Ramp Rate	—	10	8	mV/uS
<b>NOTE:</b> Refer to Chapter 3 for top package ID markings					

Table 5-4 shows the supported core frequency and core supply voltage operating ranges for the PXA27x processor. Each frequency range is specified in the following format:

(core frequency/internal system bus frequency/memory controller frequency/SDRAM frequency)

**Note:** Refer to the “Clocks and Power” section of the *Intel® PXA27x Processor Family Developers Manual* for supported frequencies, clock register settings as listed in Table 5-4.

**Table 5-4. Core Voltage and Frequency Electrical Specifications (Sheet 1 of 2)**

Symbol	Description	Min	Typical	Max	Units
Core Voltage and Frequency Range 1 (13/13/13/13)					
VVCCC1	Voltage applied on VCC_CORE	0.8075	0.85	1.595	V
fCORE1	Core operating frequency	13	—	13	MHz
Tpwrramp	Ramp Rate	—	10	8	mV/uS
Core Voltage and Frequency Range 2 (91/45.5/91/45.5) and (104/104/104/104)					
VVCCC2	Voltage applied on VCC_CORE	0.855	0.9	1.595	V
fCORE2	Core operating frequency	91	—	104	MHz
Tpwrramp	Ramp Rate	—	10	8	mV/uS
Core Voltage and Frequency Range 3 (156/104/104/104)					
VVCCC3	Voltage applied on VCC_CORE	0.95	1.00	1.595	V
fCORE3	Core operating frequency	—	156	—	MHz
Tpwrramp	Ramp Rate	—	10	8	mV/uS
Core Voltage and Frequency Range 4 (208/208/208/104)					
VVCCC4	Voltage applied on VCC_CORE	1.0925	1.15	1.595	V
fCORE4	Core operating frequency	—	208	—	MHz
Tpwrramp	Ramp Rate	—	10	8	mV/uS
Core Voltage and Frequency Range 4a (208/104/104/104)					
VVCCC4a	Voltage applied on VCC_CORE	0.9975	1.05	1.595	V
fCORE4a	Core operating frequency	—	208	—	MHz
Tpwrramp	Ramp Rate	—	10	8	mV/uS
Core Voltage and Frequency Range 5 (312/208/208/104)					
VVCCC5	Voltage applied on VCC_CORE	1.1875	1.25	1.595	V
fCORE5	Core operating frequency	—	312	—	MHz
Tpwrramp	Ramp Rate	—	10	8	mV/uS
Core Voltage and Frequency Range 5a (312/104/104/104)					
VVCCC5a	Voltage applied on VCC_CORE	0.99	1.1	1.595	V

**Table 5-4. Core Voltage and Frequency Electrical Specifications (Sheet 2 of 2)**

fCORE5a	Core operating frequency	—	312	—	MHz
Tpwrramp	Ramp Rate	—	10	8	mV/uS
Core Voltage and Frequency Range 6 (416/208/208/104)					
VVCCC6	Voltage applied on VCC_CORE	1.2825	1.35	1.595	V
fCORE6	Core operating frequency	—	416	—	MHz
Tpwrramp	Ramp Rate	—	10	8	mV/uS
Core Voltage and Frequency Range 7 (520/208/208/104)					
VVCCC7	Voltage applied on VCC_CORE	1.3775	1.45	1.595	V
fCORE7	Core operating frequency	—	520	—	MHz
Tpwrramp	Ramp Rate	—	10	8	mV/uS

The external power supplies are used to generate several internal power domains, which are shown in Table 5-5. Refer to the [Power Manager / Internal Power Domain Block Diagram](#) in the “Clocks and Power” section of the *Intel® PXA27x Processor Family Developers Manual* for more information on internal power domains.

**Table 5-5. Internally Generated Power Domain Descriptions**

Name	Units	Generation	Tolerance
VCC_REG	IO associated with deep-sleep-active units	Switched between VCC_BATT and VCC_IO	-
VCC_OSC	Oscillator power supplies	Generated from VCC_REG	+/- 30%
VCC_RTC	RTC and power manager supply	Switched between VCC_OSC and VCC_CORE	-
VCC_PI	Power manager I <sup>2</sup> C supply	Switched between VCC_OSC and VCC_CORE	-
VCC_CPU	CPU core	Independent power-down from VCC_CORE	-
VCC_PER	Peripheral units	Independent power-down from VCC_CORE	-
VCC_Rx	Particular internal SRAM unit	Switched between VCC_OSC and VCC_SRAM	-

Table 5-6 shows the recommended core voltage specification for each of the lower power modes.

**Table 5-6. Core Voltage Specifications For Lower Power Modes**

Mode	Description	Min	Typical	Max	Units
Standby	Voltage applied on VCC_CORE	1.045	1.1	1.21	V
Deep-Idle	Voltage applied on VCC_CORE	0.8075	0.85	0.935	V

## 5.3 Power-Consumption Specifications

Power consumption depends on the operating voltage and frequency, peripherals enabled, external switching activity, and external loading. Because few systems operate at maximum loading, performance, and voltage, a more optimal system design requires more typical power-consumption

figures. These values are important when considering battery size and optimizing regulator efficiency. Typical systems operate with fewer modules active and at nominal voltage and load. Refer to the appropriate top package datasheet for top package power consumption data and the *PXA270 Processor EMTS* for processor power consumption data.

## 5.4 DC Specification

The DC characteristics for each pin include input sense levels, output drive levels, and currents. These parameters can be used to determine maximum DC loading and to determine maximum transition times for a given load. [Table 5-7](#) shows the DC operating conditions for the high- and low-strength input, output, and I/O pins.

**Note:** VCC\_IO must be maintained at a voltage as high as or higher than all other supplies except VCC\_BATT and VCC\_USB.

**Table 5-7. Standard Input, Output, and I/O Pin DC Operating Conditions**

Symbol	Description	Min	Max	Units	Testing Conditions / Notes
Input DC Operating Conditions (VCC = 1.8V, 2.5, 3.0, 3.3 Typical)					
VIH <sup>1</sup>	Input high voltage, all standard input and I/O pins, relative to applicable VCC (VCC_IO, VCC_MEM, VCC_BB, VCC_LCD, or VCC_USIM)	0.8 * VCC	VCC + 0.1	V	—
VIL <sup>1</sup>	Input low voltage, all standard input and I/O pins, relative to applicable VSS (VSS_IO, VSS_MEM, or VSS_BB) and VCC (VCC_IO, VCC_MEM, VCC_BB, VCC_LCD, or VCC_USIM)	VSS - 0.1	0.2 * VCC	V	—
OS	DC Overshoot voltage / duration	—	+1	V	Max duration of 4nS
US	DC Undershoot voltage / duration	—	-1	V	Max duration of 4nS
Output DC Operating Conditions (VCC = 1.8, 2.5, 3.0, 3.3 Typical)					
VOH <sup>1</sup>	Output high voltage, all standard output and I/O pins, relative to applicable VCC (VCC_IO, VCC_MEM, VCC_BB, VCC_LCD, or VCC_USIM)	VCC - 0.3	VCC	V	IOH = -4 mA <sup>2</sup> , -3 mA <sup>3</sup>
VOL <sup>1</sup>	Output low voltage, all standard output and I/O pins, relative to applicable VSS (VSS_IO, VSS_MEM, or VSS_BB)	VSS	VSS + 0.3	V	IOH = 4 mA <sup>2</sup> , 3 mA <sup>3</sup>
<b>NOTES:</b>					
1. Programmable drive strengths set to 0x5 for memory and LCD programmable signals.					
2. The current for the high-strength pins are MA<25:0>, MD<31:0>, nOE, nWE, nSDRAS, nSDCAS, DQM<3:0>, nSDCS<3:0>, SDCKE<1>, SDCLK<3:0>, RDnWR, nCS<5:0>, and nPWE.					
3. The current for all other output and I/O pins are low strength.					

## 5.5 Oscillator Electrical Specifications

The Intel PXA27x processor contains two oscillators: a 32.768-kHz oscillator and a 13.000-MHz oscillator. Each oscillator requires a specific crystal.





## 5.5.1 32.768-kHz Oscillator Specifications

The 32.768-kHz oscillator is connected between the TXTAL\_IN (amplifier input) and TXTAL\_OUT (amplified output). Table 5-8 and Table 5-9 list the appropriate 32.768-kHz specifications.

To drive the 32.768-kHz crystal pins from an external source:

1. Drive the TXTAL\_IN pin with a digital signal that has low and high levels as listed in Table 5-9. Do not exceed VCC\_PLL or go below VSS\_PLL by more than 100 mV. The minimum slew rate is 1 volt per 1  $\mu$ s. The maximum current drawn from the external clock source when the clock is at its maximum positive voltage is typically 1 mA.
2. Float the TXTAL\_OUT pin or drive it in complement to the TXTAL\_IN pin, with the same voltage level and slew rate.

**Caution:** The TXTAL\_IN and TXTAL\_OUT pins must not be driven from an external source if the Intel PXA27x processor sleep / deep sleep DC-DC converter is enabled.

**Table 5-8. Typical 32.768-kHz Crystal Requirements**

Parameter	Minimum	Typical	Maximum	Units
Frequency range	—	32.768	—	kHz
Frequency tolerance	-30	—	+30	ppm
Frequency stability, parabolic coefficient	—	—	-0.04	ppm/ ( $\Delta^{\circ}\text{C}$ ) <sup>2</sup>
Drive level	—	—	1.0	$\mu$ W
Load capacitance ( $C_L$ )	—	12.5	—	pf
Shunt capacitance ( $C_O$ )	—	0.9	—	pf
Motional capacitance ( $C_1$ )	—	2.1	—	fF
Equivalent series resistance ( $R_S$ )	—	18	35	k $\Omega$
Insulation resistance at 100 V <sub>DC</sub>	100	—	—	M $\Omega$
Aging, at operating temperature per year	—	—	$\pm$ 3.0	ppm

Table 5-9. Typical External 32.768-kHz Oscillator Requirements

Symbol	Description	Min	Typical	Max	Units
Amplifier Specifications					
VIH_X	Input high voltage, TXTAL_IN	0.99	1.10	1.21	V
VIL_X	Input low voltage, TXTAL_IN	-0.10	0.00	0.10	V
IIN_XT	Input leakage, TXTAL_IN	—	—	1	μA
CIN_XT	Input capacitance, TXTAL_IN/ TXTAL_OUT	—	18	25	pf
tS_XT	Stabilization time	—	—	10	s
Board Specifications					
RP_XT	Parasitic resistance, TXTAL_IN/ TXTAL_OUT to any node	20	—	—	MΩ
CP_XT	Parasitic capacitance, TXTAL_IN/ TXTAL_OUT, total	—	—	5	pf
COP_XT	Parasitic shunt capacitance, TXTAL_IN to TXTAL_OUT	—	—	0.4	pf

## 5.5.2 13.000-MHz Oscillator Specifications

The 13.000-MHz oscillator is connected between the PXTAL\_IN (amplifier input) and PXTAL\_OUT (amplified output). Table 5-10 and Table 5-11 list the 13.000-MHz specifications.

To drive the 13.000-MHz crystal pins from an external source:

1. Drive the PXTAL\_IN pin with a digital signal with low and high levels as listed in Table 5-11. Do not exceed VCC\_PLL or go below VSS\_PLL by more than 100 mV. The minimum slew rate is 1 volt / 100 ns. The maximum current drawn from the external clock source when the clock is at its maximum positive voltage typically is 1 mA.
2. Float the PXTAL\_OUT pin or drive it in complement to the PXTAL\_IN pin, with the same voltage level, slew rate, and input current restrictions.

**Caution:** The PXTAL\_IN and PXTAL\_OUT pins must not be driven from an external source if the processor sleep / deep sleep DC-DC converter is enabled.

Table 5-10. Typical 13.000-MHz Crystal Requirements

Parameter	Minimum	Typical	Maximum	Units
Frequency range	12.997	13.000	13.002	MHz
Frequency tolerance at 25°C	-50	—	+50	ppm
Oscillation mode	—	Fnd	—	—
Maximum change over temperature range	-50	—	+50	ppm
Drive level	—	10	100	uW
Load capacitance (C <sub>L</sub> )	—	10	—	pf
Maximum series resistance (R <sub>S</sub> )	—	50	—	Ω
Aging per year, at operating temperature	—	—	±5.0	ppm

**Table 5-11. Typical External 13.000-MHz Oscillator Requirements**

Symbol	Description	Min	Typical	Max	Units
<b>Amplifier Specifications</b>					
VIH_X	Input high voltage, PXTAL_IN	0.99	1.10	1.21	V
VIL_X	Input low voltage, PXTAL_IN	-0.10	0.00	0.10	V
IIN_XP	Input leakage, PXTAL_IN	—	—	10	μA
CIN_XP	Input capacitance, PXTAL_IN/PXTAL_OUT	—	40	50	pf
tS_XP	Stabilization time	—	—	67.8	ms
<b>Board Specifications</b>					
RP_XP	Parasitic resistance, PXTAL_IN/PXTAL_OUT to any node	20	—	—	MΩ
CP_XP	Parasitic capacitance, PXTAL_IN/PXTAL_OUT, total	—	—	5	pf
COP_XP	Parasitic shunt capacitance, PXTAL_IN to PXTAL_OUT	—	—	0.4	pf

## 5.6 CLK\_PIO and CLK\_TOUT Specifications

CLK\_PIO can be used to drive a buffered version of the PXTAL\_IN oscillator input or can be used as a clock input alternative to PXTAL\_IN. Refer to [Table 5-12](#) for CLK\_PIO specifications.

A buffered and inverted version of the PXTAL\_IN oscillator output is driven out on CLK\_TOUT. Refer to [Table 5-13](#) for CLK\_TOUT specifications.

**Note:** CLK\_TOUT and CLK\_PIO are only available when software sets the OSCC[PIO\_EN] and OSCC[TOUT\_EN] bits.

**Table 5-12. CLK\_PIO Specifications**

Parameter	Specifications
Frequency	13 MHz
Frequency Accuracy (derived from 13 MHz crystal)	+/-200ppm
Symmetry/Duty Cycle variation	30/70 to 70/30% at VCC
Jitter	+/-20pS max
Load capacitance (C <sub>L</sub> )	50pf max
Rise and Fall time (Tr & Tf)	15nS max with 50pF load

**Table 5-13. CLK\_TOUT Specifications**

Parameter	Specifications
Frequency	32KHz
Frequency Accuracy (derived from 32 kHz crystal)	+/-200ppm
Symmetry/Duty Cycle variation	30/70 to 70/30% at VCC

**Table 5-13. CLK\_TOUT Specifications**

Parameter	Specifications
Jitter	+/-20pS max
Load capacitance ( $C_L$ )	50pf max
Rise and Fall time ( $T_r$ & $T_f$ )	15nS max with 50pF load

## 5.7 48 MHz Output Specifications

Software may configure GPIO<11> or GPIO<12> alternate functions to enable the 48 MHz clock output. The 48-MHz output clock is a divided down output generated from the 312-MHz peripheral PLL. Refer to [Table 5-14](#) for the 48 MHz output specifications. Refer to Section 3 of this document for GPIO alternate functions in the Pin Usage Table.

**Table 5-14. 48 MHz Output Specifications**

Parameter	Specifications
Frequency (derived from 13 MHz crystal)	48 MHz
Frequency Accuracy (derived from 13 MHz crystal)	+/-200ppm (maximum)
Symmetry/Duty Cycle variation	30/70 to 70/30% at VCC
Jitter	+/-20pS max
Load capacitance ( $C_L$ )	50pf max
Rise and Fall time ( $T_r$ & $T_f$ )	15nS max with 50pF load

§§

# AC Timing Specifications

# 6

A pin's alternating-current (AC) characteristics include input and output capacitance. These factors determine the loading for external drivers and other load analyses. The AC characteristics also include a derating factor, which indicates how much the AC timings might vary with different loads.

**Note:** The timing diagrams in this chapter show bursts that start at 0 and proceed to 3 or 7. However, the least significant address (0) is not always received first during a burst transfer, because the Intel PXA27x processor requests the critical word first during burst accesses.

Table 6-1 shows the AC operating conditions for the high- and low-strength input, output, and I/O pins. All AC specification values are valid for the device's entire temperature range.

**Table 6-1. Standard Input, Output, and I/O-Pin AC Operating Conditions**

Symbol	Description	Min	Typical	Max	Units
$C_{IN}$	Input capacitance, all standard input and I/O pins	—	—	10	pf
$C_{OUT\_H}$	Output capacitance, all standard high-strength output and I/O pins	20	—	50	pf
$td_{F\_H}$	Output derating, falling edge on all standard, high-strength output and I/O pins, from 50-pf load.	—	TBD	—	ns/pf
$td_{R\_H}$	Output derating, rising edge on all standard, high-strength output and I/O pins, from 50-pf load.	—	TBD	—	ns/pf
$C_{OUT\_L}$	Output capacitance, all standard low-strength output and I/O pins	20	—	50	pf
$td_{F\_L}$	Output derating, falling edge on all standard, low-strength output and I/O pins, from 50-pf load.	—	TBD	—	ns/pf
$td_{R\_L}$	Output derating, rising edge on all standard, low-strength output and I/O pins, from 50-pf load.	—	TBD	—	ns/pf

## 6.1 AC Test Load Specifications

Figure 6-1 represents the timing reference load used in defining the relevant timing parameters of the part. It is not intended to be either a precise representation of the typical system environment nor a depiction of the actual load presented by a production tester. System designers use IBIS or other simulation tools to correlate the timing reference load to system environment. Manufacturers correlate to their production test conditions (generally a coaxial transmission line terminated at the tester electronics).

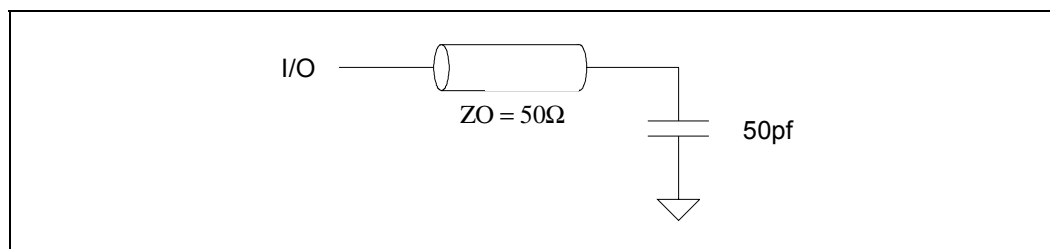
**Figure 6-1. AC Test Load**

## 6.2 Reset and Power Manager Timing Specifications

The processor asserts the nRESET\_OUT pin in one of several different modes:

- Power-on reset
- Hardware reset
- Watchdog reset
- GPIO reset
- Sleep mode
- Deep-sleep mode

The following sections give the timing and specifications for entry into and exit from these modes.

### 6.2.1 Power-On Timing Specifications

Power-on reset begins when a power supply is detected on the backup battery pin, VCC\_BATT, after the processor has been powered off. A power-on reset is equivalent to a hardware reset, in that all units are reset to the same known state as with a hardware reset. A power-on reset is a complete and total reset that occurs only at initial power on.

The external power-supply system must enable the power supplies for the processor in a specific sequence to ensure proper operation. [Figure 6-2](#) shows the timing diagram for a power-on reset sequence. [Table 6-2](#) details the timing.

The sequence for power-on reset is as follows:

1. VCC\_BATT is established, then nRESET should be de-asserted to initiate power-on reset.
2. PWR\_OUT is asserted. The processor asserts nRESET\_OUT.
3. The external power-control subsystem de-asserts nBATT\_FAULT to signal that the main battery is connected and not discharged.
4. The processor asserts the SYS\_EN signal to enable the power supplies VCC\_IO, VCC\_MEM, VCC\_BB, VCC\_USB, and VCC\_LCD. VCC\_USIM can be established at this time also but can be independently controlled through its own control signals. VCC\_IO must be established first. The other supplies can turn on in any order, but they must all be established within 125 milliseconds of the assertion of SYS\_EN.

5. The processor asserts the PWR\_EN signal to enable the power supplies VCC\_CORE, VCC\_SRAM, and VCC\_PLL. These supplies can turn on in any order but must all be established within 125 milliseconds of the assertion of PWR\_EN.
6. The external power-control subsystem de-asserts nVDD\_FAULT to signal that all system power supplies have been properly established.
7. The processor de-asserts nRESET\_OUT and enters run mode, executing code from the reset vector.

**Note:** nBATT\_FAULT must be high before nRESET is de-asserted. Otherwise, the processor does not begin the power-on sequencing event. nVDD\_FAULT is sampled only when the SYS\_DEL and PWR\_DEL timers have expired. Refer to the *Intel® PXA27x Processor Family Developer's Manual*, “Initial Power On” and “Deep-Sleep Exit States” for a state diagram.

**Figure 6-2. Power On Reset Timing**

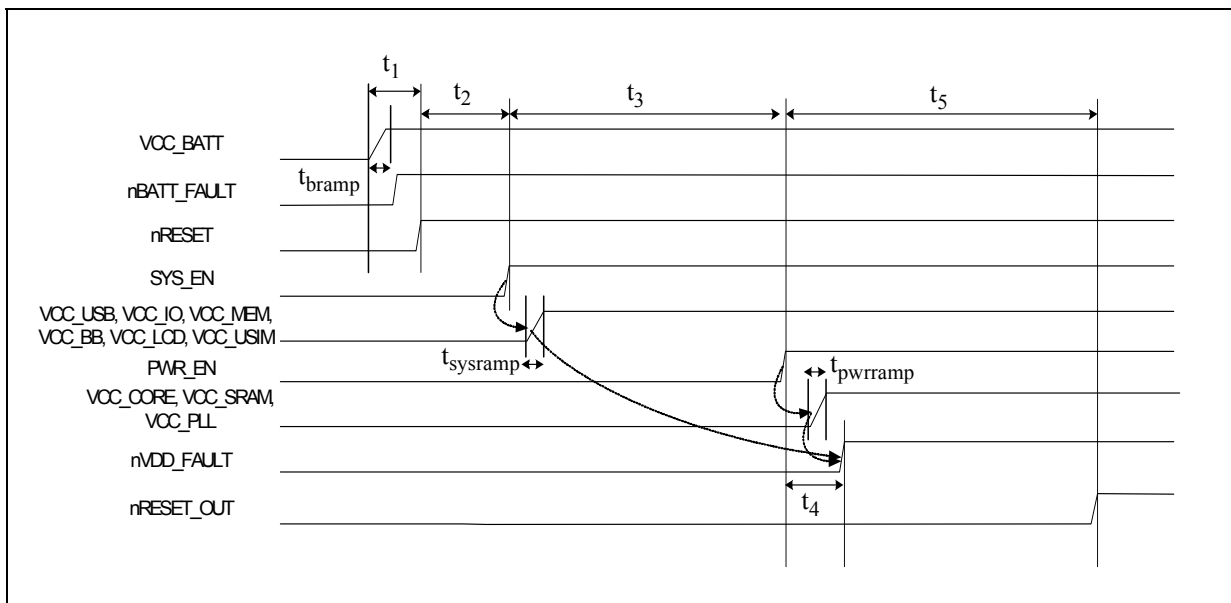

**Table 6-2. Power-On Timing Specifications (Sheet 1 of 2)(OSCC[CRI] = 0)**

Symbol	Description	Min	Typical	Max	Units
$t_1$	Delay from VCC_BATT assertion to nRESET de-assertion	10	—	—	ms
$t_2$	Delay from nRESET de-assertion to SYS_EN assertion	—	10 <sup>1</sup>	—	ms
$t_3$	Delay from SYS_EN assertion to PWR_EN assertion	—	125	—	ms
$t_4$	Power supply stabilization time (time to the deassertion of nVDD_FAULT after the assertion of PWR_EN)	—	—	120	ms
$t_5$	Delay from the assertion of PWR_EN to the de-assertion of nRESET_OUT	—	125	—	ms
$t_{bramp}$	VCC_BATT power-on Ramp Rate	—	10	8	mV/uS

Table 6-2. Power-On Timing Specifications (Sheet 2 of 2)(OSCC[CRI] = 0)

Symbol	Description	Min	Typical	Max	Units
$t_{\text{sysramp}}$	Power-on Ramp Rate for all external high-voltage power domains	—	10	8	mV/uS
$t_{\text{pwrramp}}$	Power-on Ramp Rate for all external low-voltage power domains (including dynamic voltage changes on VCC_CORE)	—	10	8	mV/uS

**NOTES:**

1. If the OSCC[CRI] = 1 then the delay from nRESET de-assertion to SYS\_EN assertion is 3000mS

**NOTE:** This long delay is attributed to the fact that when the CRI bit is read as 1, (which indicates that the CLK\_REQ pin was floated during a hardware or power-on reset) the processor oscillator is supplied externally. This then forces the system to wait for the 32 kHz oscillator and the 13 MHz oscillator to stabilize.

## 6.2.2 Hardware Reset Timing

The timing sequences shown in Figure 6-3 for hardware reset and the specifications in Table 6-3 and Table 6-4 assume stable power supplies at the assertion of nRESET. Follow the timings indicated in Section 6.2.1 if the power supplies are unstable.

Figure 6-3. Hardware Reset Timing

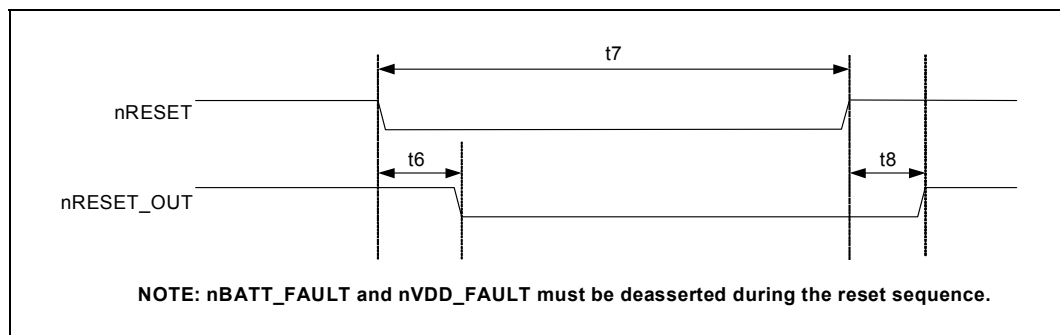

Table 6-3. Hardware Reset Timing Specifications (OSCC[CRI] = 0)

Symbol	Description	Min	Typical	Max	Units
$t_6$	Delay between nRESET asserted and nRESET_OUT asserted	—	< 100 ns	10	ms
$t_7$	Assertion time of nRESET	6	—	—	ms
$t_8$	Delay between nRESET de-asserted and nRESET_OUT de-asserted	256	—	265	ms



**Table 6-4. Hardware Reset Timing Specifications (OSCC[CRI] = 1)**

Symbol	Description	Min	Typical	Max	Units
$t_6$	Delay between nRESET asserted and nRESET_OUT asserted	—	< 100 ns	10	ms
$t_7$	Assertion time of nRESET	6	—	—	ms
$t_8$	Delay between nRESET de-asserted and nRESET_OUT de-asserted	2256	—	3265	ms

### 6.2.3 Watchdog Reset Timing

Watchdog reset is generated internally and therefore has no external pin dependencies. The nRESET\_OUT pin is the only indicator of watchdog reset; it stays asserted for  $t_{DHW\_OUT}$ . The timing is similar to that for GPIO reset — see [Figure 6-4](#) for details.

### 6.2.4 GPIO Reset Timing

GPIO reset is generated externally, and the source is reconfigured as a standard GPIO as soon as the reset propagates internally. The clocks module is not reset by GPIO reset, so the timing varies based on the selected clock frequency. If the clocks and power manager is in a frequency-change sequence when GPIO reset is asserted (see [Section 5.5.1, “32.768-kHz Oscillator Specifications” on page 5-7.](#)), then [Figure 6-4](#) shows the timing of GPIO reset, and [Table 6-5](#) shows the GPIO reset timing specifications.

**Note:** When bit GPROD is set in the Power Manager General Configuration register, nRESET\_OUT is not asserted during GPIO reset. For register details, see the “Clocks and Power Manager” chapter in the *Intel® PXA27x Processor Family Developer’s Manual*.

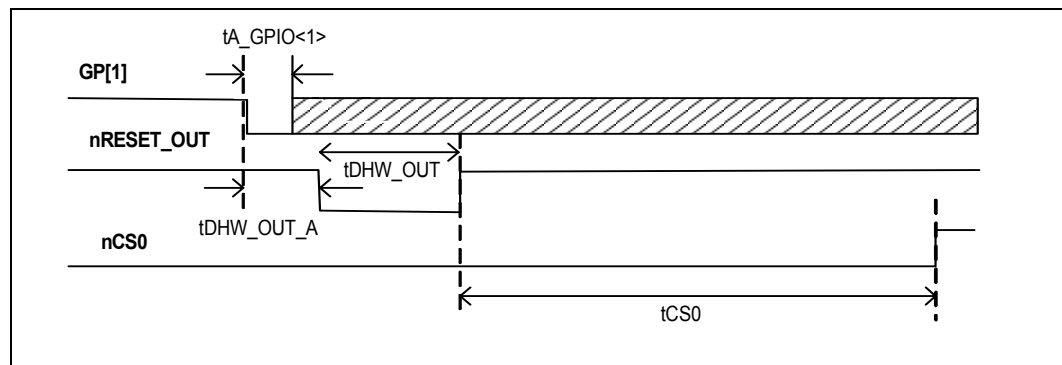
**Figure 6-4. GPIO Reset Timing**

**Table 6-5. GPIO Reset Timing Specifications**

Symbol	Description	Min	Typical	Max	Units
tA_GPIO<1>	Minimum assert time of GPIO<1> <sup>1</sup> in 13.000-MHz input clock cycles	4 <sup>4</sup>	—	—	cycles
tDHW_OUT_A	Delay between GPIO<1> asserted and nRESET_OUT asserted in 13.000-MHz input clock cycles	6 <sup>4</sup>	—	8	cycles
tDHW_OUT	Delay between nRESET_OUT asserted and nRESET_OUT de-asserted, run or turbo mode <sup>2</sup>	230	—	—	nsec
tDHW_OUT_F	Delay between nRESET_OUT asserted and nRESET_OUT de-asserted, during frequency change sequence <sup>3</sup>	5	—	380	μs
tCS0 <sup>5</sup>	Delay between nRESET_OUT de-assertion and nCS0 assertion	1000	—	—	ns

**NOTES:**

- GPIO<1> is not recognized as a reset source again until configured to do so in software. Software must check the state of GPIO<1> before configuring as a reset to ensure that no spurious reset is generated. For details, see the “Clocks and Power Manager” chapter in the *Intel® PXA27x Processor Family Developer’s Manual*.
- Time is 512\*N processor clock cycles plus up to 4 cycles of the 13.000-MHz input clock.
- Time during the frequency-change sequence depends on the state of the PLL lock detector at the assertion of GPIO reset. The lock detector has a maximum time of 350 μs plus synchronization.
- In standby, sleep, and deep-sleep modes, this time is in addition to the wake-up time from the low-power mode.
- The tCS0 specification is also applicable to Power-On reset, Hardware reset, Watchdog reset and Deep-Sleep/Sleep mode exit.

## 6.2.5 Sleep Mode Timing

Sleep mode is internally asserted, and it asserts the nRESET\_OUT and PWR\_EN signals. Figure 6-5 and Table 6-6 show the required timing parameters for sleep mode.

**Note:** When bit SL\_ROD is set in the Power Manager Sleep Configuration register, nRESET\_OUT, is not asserted during GPIO reset. See the “Clocks and Power Manager” chapter in the *Intel® PXA27x Processor Family Developer’s Manual* for register details.

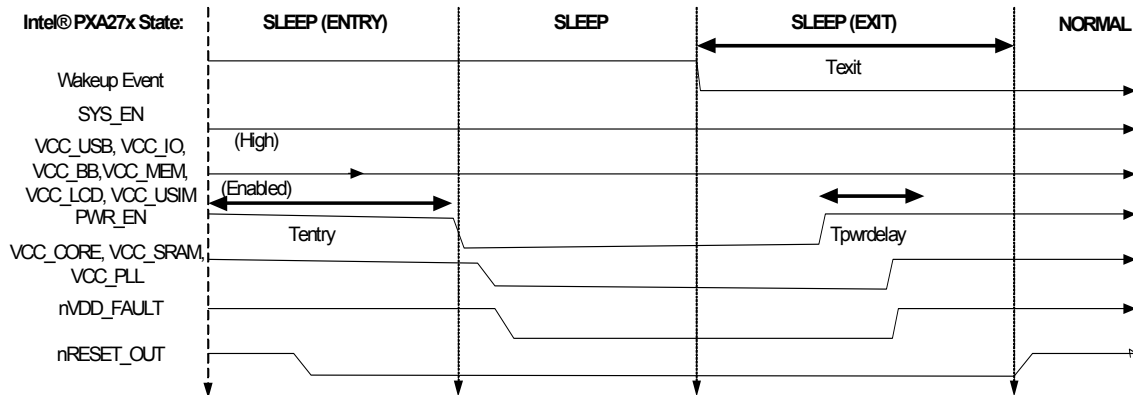
**Figure 6-5. Sleep Mode Timing**

**Table 6-6. Sleep-Mode Timing Specifications**

Symbol	Description	Min	Typical	Max <sup>3</sup>	Units
$t_{entry}^5$	Delay between MCR sleep command issue to de-assertion of PWR_EN	0.56	—	2.5 <sup>1</sup>	msec
$t_{exit}$	Delay between wakeup event and run mode	0.50	—	136.65 <sup>2,4</sup>	msec
$t_{pwrdelay}$	Delay between assertion of PWR_EN to PLL enable <sup>2</sup>	0	—	125	msec

**NOTES:**

- 1mS if not using DC2DC and -0.94mS if any internal SRAM banks are not powered
- 0.15mS less time if exiting from sleep mode to 13M mode
- Add 0.1mS if the wake up event is external
- Oscillator start/crystal stable times are programmable (300uS-11mS)

**NOTE:** 6mS is user programmable using the OSCC[OSD] bit. The remaining 5mS is an internal timer which counts until the oscillator is stable. (Typical stabilization is 500uS. Maximum can be upto 5mS)

- nRESET\_OUT and nVDD\_FAULT are programmable during sleep mode

## 6.2.6 Deep-Sleep Mode Timing

Deep-sleep mode is internally asserted, and it asserts the nRESET\_OUT and PWR\_EN signals. Figure 6-6 and Table 6-7 show the required timing parameters for sleep mode. The timing specifications listed are for software-invoked (not battery or VDD fault) deep-sleep entry, unless specified.

Figure 6-6. Deep-Sleep-Mode Timing

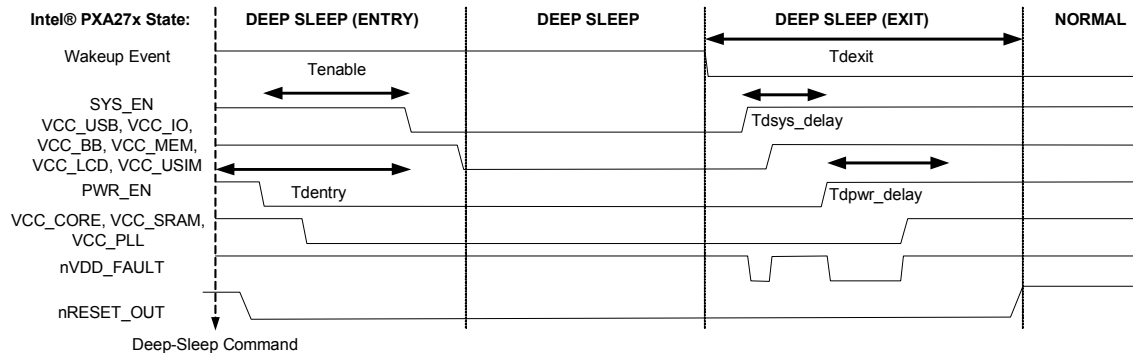

Table 6-7. Deep-Sleep Mode Timing Specifications

Symbol	Description	Min	Typical	Max <sup>3</sup>	Units
$t_{dentry}^5$	Delay between deep-sleep command issue to de-assertion of SYS_EN	0.66	—	1.66 <sup>1</sup>	msec
$t_{enable}$	Delay between de-assertion of PWR_EN and SYS_EN	—	30	—	usec
$t_{dexit}$	Delay between wakeup event and run mode	0.60	—	261.75 <sup>2,4</sup>	msec
$t_{dsysdelay}$	Delay between assertion of SYS_EN to PWR_EN <sup>2</sup>	0	—	125	msec
$t_{dpwrdelay}$	Delay between assertion of PWR_EN to PLL enable <sup>2</sup>	0	—	125	msec
<b>NOTE:</b> Timing specifications for nBATT_FAULT and/or nVDD_FAULT asserted deep-sleep mode entry are below:					
Fault assert	Delay between nBATT_FAULT or nVDD_FAULT assertion (during all modes of operation including sleep mode) and deep-sleep mode entry <sup>6</sup> (The de-assertion of SYS_EN defines when the processor is in deep-sleep mode)	0.33	—	1.56	msec

**NOTES:**

1. -1mS if not using DC2DC
2. 0.15mS less time if exiting from deep-sleep mode to 13M mode
3. Add 0.1ms if the wake up event is external
4. Oscillator start/crystal stable times are programmable (300 $\mu$ S-11mS)

**NOTE:** 6ms is user programmable using the OSCC[OSD] bit. The remaining 5ms is an internal timer which counts until the oscillator is stable. (Typical stabilization is 500 $\mu$ s. Maximum can be upto 5ms)

5. nRESET\_OUT and nVDD\_FAULT are programmable during sleep mode
6. Assumes PMCR[BIDAE or VIDAE] bits are set to zero (default state) - The PMCR[BIDAE or VIDAE] bits are only read by the processor if nBATT\_FAULT or nVDD\_FAULT signals are asserted



### 6.2.6.1 GPIO States in Deep-Sleep Mode

If the external high voltage power domains (VCC\_IO, VCC\_MEM, VCC\_BB, VCC\_LCD, VCC\_USB, VCC\_USIM) remain powered on during deep-sleep, the PGSR values are driven onto all the GPIO pins (that are configured as outputs) for a finite time period, then the pins default to the reset state (Pu/Pd) as described in Chapter 2 of this manual. This sequence occurs for either software initiated or fault initiated deep-sleep entry.

**Note:** GPIOs<0,1,3,4,9,10> never float. They are powered from VCC\_BATT so when the system and the core power domains are removed (controlled by SYS\_EN and PWR\_EN), the Pu/Pd resistors are still enabled due to VCC\_BATT remaining on.

The delay between the initiation of deep-sleep mode and enabling the GPIO Pu/Pd states, is system dependant because the processor is performing an unpredictable workload and requires an unknown amount of time to complete current processes. Refer to the deep-sleep mode, “Clocks and Power” section of the *Intel® PXA27x Processor Family Developers Manual* for a description on deep-sleep mode entry sequence.

Table 6-8 shows the time period that the GPIO pull-up/pull-downs are enabled. Listed below are the regulators and converter naming conventions:

L1 = Sleep/Deep-Sleep Linear Regulator

L2 = High-Current Linear Regulator

DC2DC = Sleep/Deep-Sleep DC-DC Converter

**Table 6-8. GPIO Pu/Pd Timing Specifications for Deep-Sleep Mode**

Description	L2	L1	DC2DC	Units
Duration of the GPIO Pu/Pd states being enabled and the de-assertion of PWR_EN	0.1	0.13	1.13	msec

**Note:** If the *external high voltage power domains* (VCC\_IO, VCC\_MEM, VCC\_BB, VCC\_LCD, VCC\_USB, VCC\_USIM) are powered off during deep-sleep mode, the GPIOs behave the same as described above; however, they float after the supplies are removed.

## 6.2.7 Standby-Mode Timing

Table 6-9. Standby-Mode Timing Specifications

Symbol	Description	Min	Typical	Max	Units
—	13M mode to standby mode entry	—	0.34	—	msec
—	Standby mode exit to 13M mode <sup>1</sup>	0.28	—	11.28 <sup>2</sup>	msec
—	Run mode to standby mode entry	—	0.34	—	msec
—	Standby mode exit to run mode <sup>1</sup>	0.43	0.39	11.43 <sup>2</sup>	msec

**NOTES:**

1. The 13M oscillator is programmable
2. Add 0.1mS if the wake up event is external

## 6.2.8 Idle-Mode Timing

Table 6-10. Idle-Mode Timing Specifications

Symbol	Description	Min	Typical	Max	Units
—	13M mode to deep idle mode entry	—	1	—	μs
—	Deep idle mode exit to 13M mode	—	1	—	μs
—	Run mode to idle run mode entry	—	1	—	μs
—	Idle run mode exit to run mode	—	1	—	μs

## 6.2.9 Frequency-Change Timing

Table 6-11. Frequency-Change Timing Specifications

Symbol	Description	Min	Typical	Max	Units
—	Delay between MCR command to frequency change sequence completion	—	150 <sup>1</sup>	—	μs
—	Delay to change between turbo, half-turbo and run modes	—	1 <sup>2</sup>	—	μs
—	Delay to enter 13M mode from any Run mode <sup>3</sup>	—	1	—	μs
—	Delay to exit 13M mode to any Run mode	—	2 <sup>4</sup>	—	μs

**NOTES:**

1. Any change to the CCCR[2N or L] bits followed by a write to CLFCFG[F] to initiate a frequency change sequence, results in a PLL restart
2. Changing between turbo, half-turbo and run modes does not require a PLL restart
3. Software can only change into 13M mode from any Run mode
4. Assuming software uses the PLL early enable feature (CCCR[PLL\_EARLY\_EN] prior to a frequency change sequence

## 6.2.10 Voltage-Change Timing

The PWR I<sup>2</sup>C uses the regular I<sup>2</sup>C protocol. The PWR I<sup>2</sup>C is clocked at 40 kHz (160 kHz fast-mode operation is supported). Software controls the time required for initiating the voltage change sequence through completion. The voltage-change timing is a product of the number of commands issued plus the number of software programmed delays. Table 6-12 shows the timing of a 1 byte command issued to the power manager IC.

Set the I<sup>2</sup>C programmable output ramp rate with a default/reset ramp rate of 10mV/μs (±20%) to support VCC\_CORE dynamic voltage management.

**Table 6-12. Voltage-Change Timing Specification for a 1-Byte Command**

Symbol	Description	Min	Typical	Max	Units
—	Delay between voltage change sequence start <sup>1</sup> to command received by PMIC	—	18	—	cycles <sup>2</sup>

**NOTES:**

1. Write 1 to PWRMODE[VC]
2. 40 kHz cycles

## 6.3 GPIO Timing Specifications

Table 6-13 shows the general-purpose I/O (GPIO) AC timing specifications.

**Table 6-13. GPIO Timing Specifications**

Symbol	Parameter	Min	Max	Units	Notes
taGPIO <sup>1</sup>	Assertion time required to detect GPIO edge	154	—	ns	run, idle, or sense power modes
taGPIOLP <sup>2</sup>	Assertion time required to detect GPIO low-power edge	62.5	—	μs	standby, sleep, or deep-sleep power modes
tdGPIO <sup>1</sup>	De-assertion time required to detect GPIO edge	154	—	ns	run, idle, or sense power modes
tdGPIOLP <sup>2</sup>	De-assertion time required to detect GPIO low-power edge	62.5	—	μs	standby, sleep, or deep-sleep power modes
tdiGPIO <sup>3</sup>	Time it takes for a GPIO edge to be detected internally	231	—	ns	run, idle, or sense power modes
tdiGPIOLP <sup>4</sup>	Time it takes for a GPIO low-power edge to be detected internally	93.75	—	μs	standby, sleep, or deep-sleep power modes

**NOTES:**

1. Period equal to two 13-MHz cycles
  2. Period equal to two 32-kHz cycles
  3. Period equal to three 13-MHz cycles
  4. Period equal to three 32-kHz cycles
- Note 4 describes the complete timing for a standby, sleep, or deep-sleep wake up source to be asserted and detected internally (2 cycles for assertion (note 2) and 1 additional cycle for detection).

## 6.4 Memory and Expansion-Card Timing Specifications

Interfaces with the following memories must observe the AC timing requirements given in the following subsections:

- Section 6.4.1, “Internal SRAM Read/Write Timing Specifications”
- Section 6.4.2, “SDRAM Parameters and Timing Diagrams”
- Section 6.4.3, “ROM Parameters and Timing Diagrams”
- Section 6.4.4, “Flash Memory Parameters and Timing Diagrams”
- Section 6.4.5, “SRAM Parameters and Timing Diagrams”
- Section 6.4.6, “Variable-Latency I/O Parameters and Timing Diagrams”
- Section 6.4.7, “Expansion-Card Interface Parameters and Timing Diagrams”

**Note:** The diagrams in this section use the following conventions:

- Input signals to the processor are represented using dashed waveforms.
- Outputs and bidirectional signals are represented using solid waveforms.
- Fixed parameters are shown using double arrows in grey (black and white print) or green (color print).
- Programmable parameters are shown using bold single arrows.
- The processor register that is used to change a specific timing is given in the corresponding timing table.

### 6.4.1 Internal SRAM Read/Write Timing Specifications

Table 6-14. SRAM Read/Write AC Specification

Symbols	Parameters	MIN	TYP	MAX	Units
tsramRD	4-beat read transfer	—	9	—	system bus clocks
tsramWR	4-beat write transfer	—	7	—	system bus clocks

### 6.4.2 SDRAM Parameters and Timing Diagrams

Table 6-15 shows the timing parameters used in Figure 6-7. Also see Section 6.4.3 and Figure 6-11 for additional SDRAM bus tenure information. See Figure 6-10 for SDRAM fly-by bus tenures.



**Table 6-15. SDRAM Interface AC Specifications (Sheet 1 of 2)**

Symbols	Parameters	VCC_MEM = 1.8V +20% / -5% <sup>3</sup>			VCC_MEM = 2.5V +/- 10% <sup>4</sup>			VCC_MEM = 3.3V +/- 10% <sup>5</sup>			Units	Notes
		MIN	TYP	MAX	MIN	TYP	MAX	MIN	TYP	MAX		
tsdCLK	SDCLK1, SDCLK2 period	9.6	—	76.9	9.6	—	76.9	9.6	—	76.9	ns	1, 2
tsdCMD	nSDCAS, nSDRAS, nWE, nSDCS assert time	1	—	1	1	—	1	1	—	1	SDCLK	—
tsdCAS	nSDCAS to nSDCAS assert time	2	—	—	2	—	—	2	—	—	SDCLK	—
tsdRCD	nSDRAS to nSDCAS assert time	1	MDCNFG [DTCx]	3	1	MDCNFG [DTCx]	3	1	MDCNFG [DTCx]	3	SDCLK	6
tsdRP	nSDRAS Pre charge	2	MDCNFG [DTCx]	3	2	MDCNFG [DTCx]	3	2	MDCNFG [DTCx]	3	SDCLK	6
tsdCL	nSDRAS to nSDCAS delay	2	MDCNFG [DTCx]	3	2	MDCNFG [DTCx]	3	2	MDCNFG [DTCx]	3	SDCLK	6
tsdRAS	nSDRAS active time	3	MDCNFG [DTCx]	7	3	MDCNFG [DTCx]	7	3	MDCNFG [DTCx]	7	SDCLK	6
tsdRC	nSDRAS cycle time	4	MDCNFG [DTCx]	11	4	MDCNFG [DTCx]	11	4	MDCNFG [DTCx]	11	SDCLK	6
tsdWR	write recovery time (time from last data in the PRECHARGE)	2	—	2	2	—	2	2	—	2	SDCLK	—
tsdSDOS	MA<24:10>, MD<31:0>, DQM<3:0>, nSDCS<3:0>, nSDRAS, nSDCAS, nWE, nOE, SDCKE1, RDnWR output setup time to SDCLK<2:1> rise	TBD	—	—	TBD	—	—	TBD	—	—	ns	—
tsdSDOH	MA<24:10>, MD<31:0>, DQM<3:0>, nSDCS<3:0>, nSDRAS, nSDCAS, nWE, nOE, SDCKE1, RDnWR output hold time from SDCLK<2:1> rise	TBD	—	—	TBD	—	—	TBD	—	—	ns	—
		VCC_CORE = 0.85 V +/- 10%, with 1.71 V <= VCC_MEM <= 3.63 V			VCC_CORE = 1.1 V +/- 10%, with 1.71 V <= VCC_MEM <= 3.63 V			VCC_CORE = 1.3 V +/- 10%, with 1.71 V <= VCC_MEM <= 3.63 V				

**Table 6-15. SDRAM Interface AC Specifications (Sheet 2 of 2)**

Symbols	Parameters	VCC_MEM = 1.8V +20% / -5% <sup>3</sup>			VCC_MEM = 2.5V +/- 10% <sup>4</sup>			VCC_MEM = 3.3V +/- 10% <sup>5</sup>			Units	Notes
		MIN	TYP	MAX	MIN	TYP	MAX	MIN	TYP	MAX		
tsdSDIS	MD<31:0> read data input setup time from SDCLK<2:1> rise	TBD	—	—	0.5	—	—	0.5	—	—	ns	—
tsdSDIH	MD<31:0> read data input hold time from SDCLK<2:1> rise	TBD	—	—	1.8	—	—	1.8	—	—	ns	—

**NOTES:**

- SDCLK for SDRAM slowest period is accomplished by divide-by-2 of the 26-MHz CLK\_MEM. The fastest possible SDCLK is accomplished by configuring CLK\_MEM at 104 MHz and not setting MDREFR[KxDB2].
- SDCLK1 and SDCLK2 frequencies are configured to be CLK\_MEM frequency divided by 1 or 2, depending on the bit fields MDREFR[K1DB2] and MDREFR[K2DB2] settings.
- These numbers are for VCC\_MEM = 1.8 V +20% / -5%, VOL = 0.4 V, and VOH = 1.4 V, with each applicable 4-bit field of the system memory buffer strength registers (BSCNTRP and BSCNTRN) set to TBD (msb:lsb) and each applicable SDCLK<2:1> divide-by-2 and divide-by-4 register bits MDREFR[KxDB2] clear.
- These numbers are for VCC\_MEM = 2.5 V +/- 10%, VOL = 0.4 V, and VOH = 2.1 V, with each applicable 4-bit field of the system memory buffer strength registers (BSCNTRP and BSCNTRN) set to 0b1010 (msb:lsb) and each applicable SDCLK<2:1> divide-by-2 and divide-by-4 register bit MDREFR[KxDB2] clear.
- These numbers are for VCC\_MEM = 3.3 V +/- 10%, VOL = 0.4 V, and VOH = 2.4 V, with each applicable 4-bit field of the system memory buffer strength registers (BSCNTRP and BSCNTRN) set to 0b1010 (msb:lsb) and each applicable SDCLK<2:1> divide-by-2 and divide-by-4 register bit MDREFR[KxDB2] clear.
- Refer to the "Memory Controller" chapter in the *Intel® PXA27x Processor Family Developer's Manual* for register configuration.

Figure 6-7. SDRAM Timing

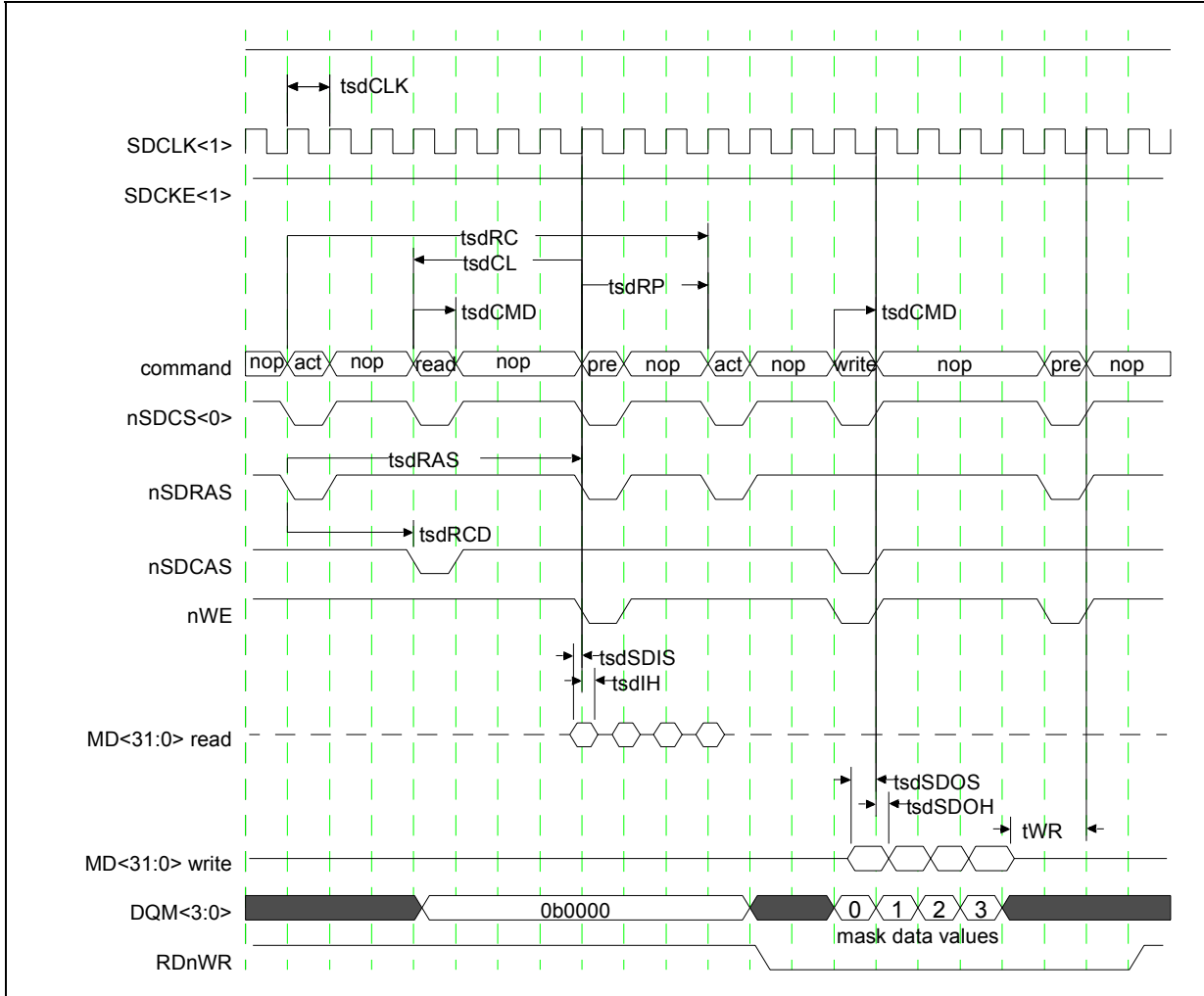

Figure 6-8. SDRAM 4-Beat Read/4-Beat Write, Different Banks Timing

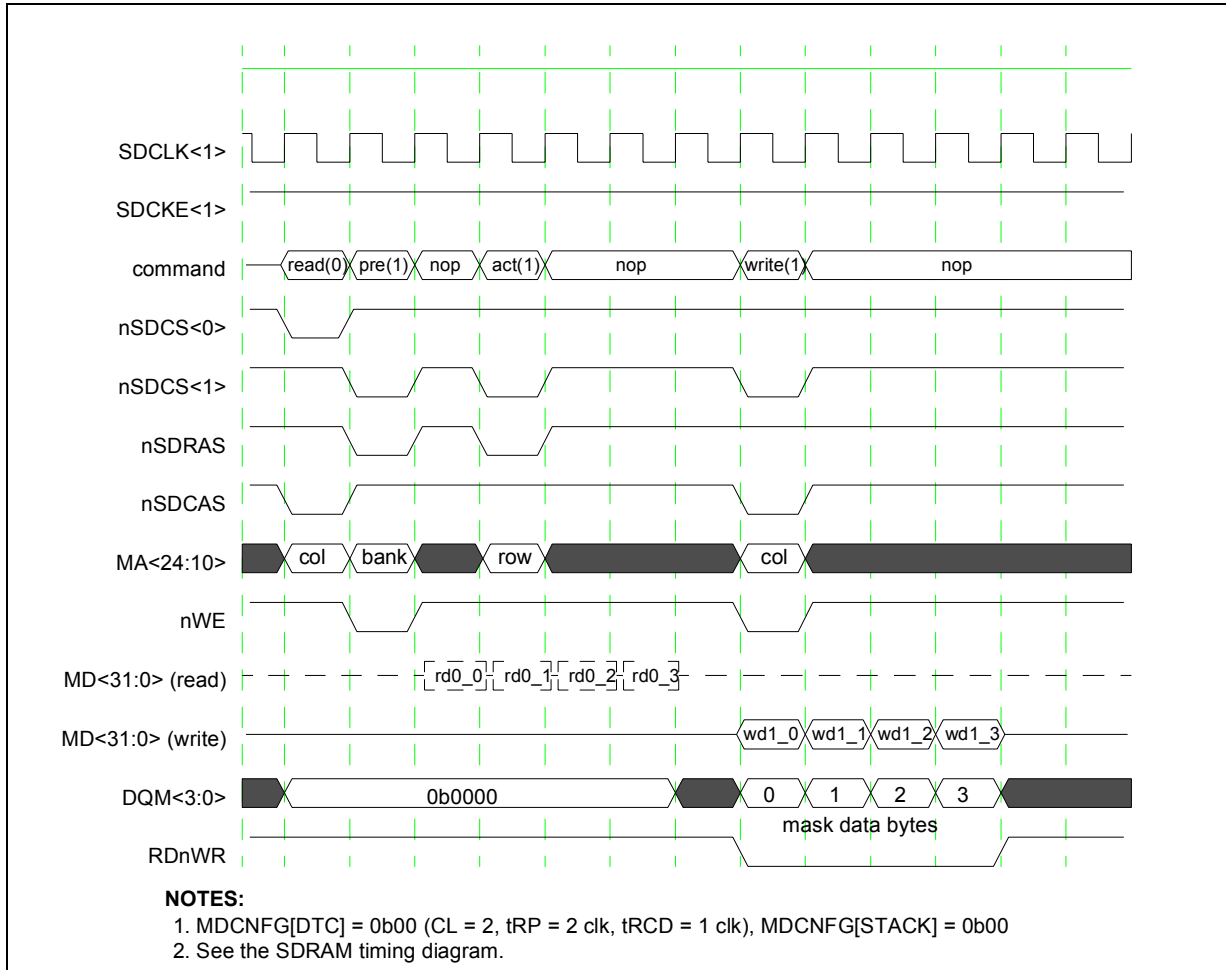

Figure 6-9. SDRAM 4-Beat Write/4-Beat Write, Same Bank-Same Row Timing

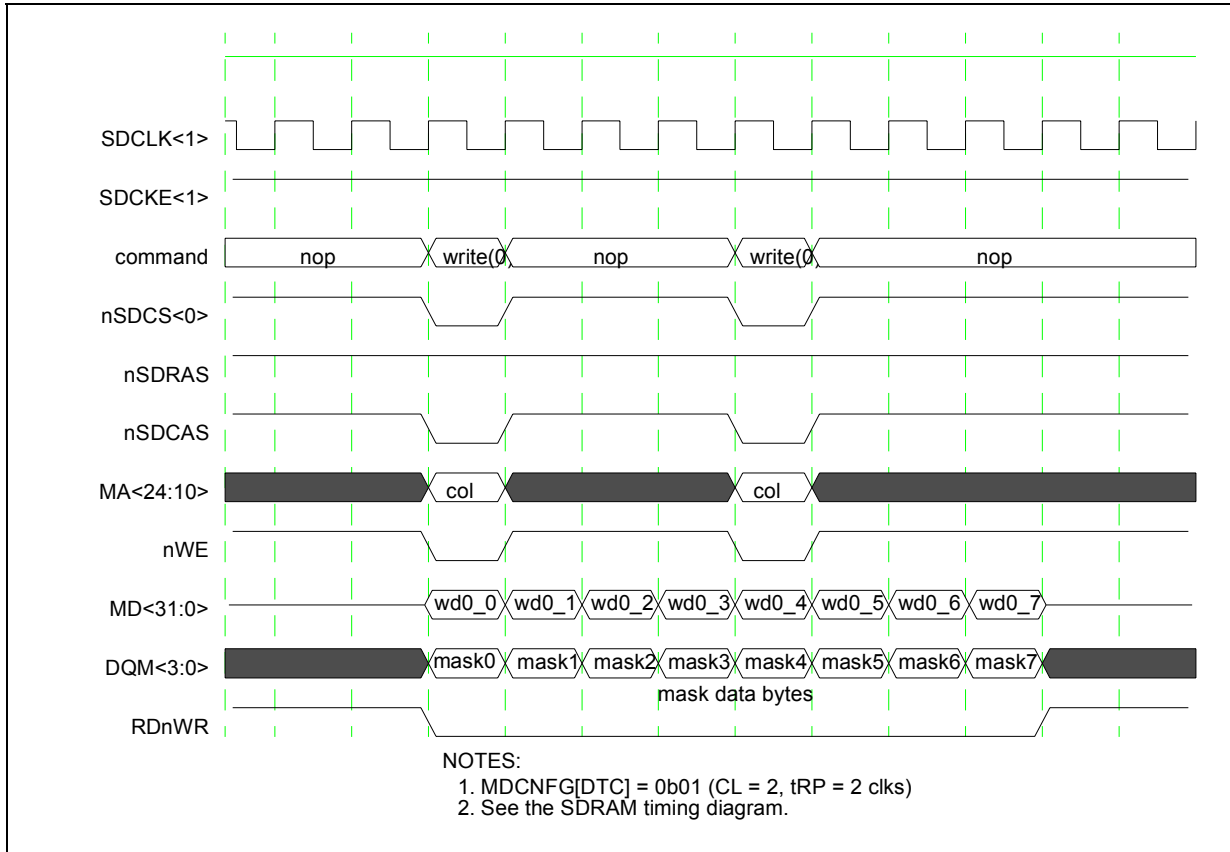
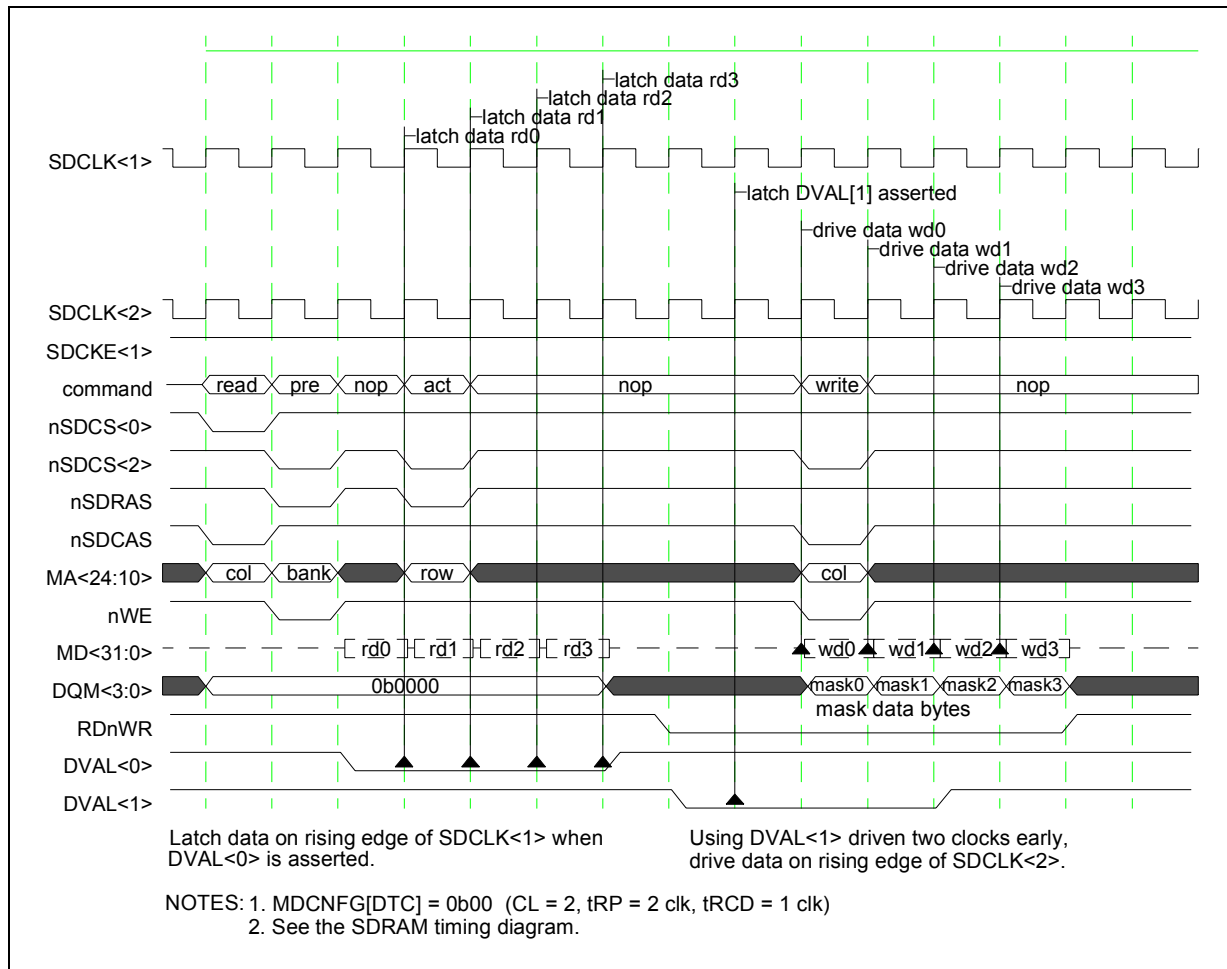

Figure 6-10. SDRAM Fly-by DMA Timing



### 6.4.3 ROM Parameters and Timing Diagrams

Table 6-16 lists the timings for ROM reads. See Figure 6-11, Figure 6-12, Figure 6-13, and Figure 6-14 for timing diagrams representing burst and non-burst ROM reads.

**Note:** Table 6-16 lists programmable register items. See the “Memory Controller” chapter in the *Intel® PXA27x Processor Family Developer’s Manual* for register configurations for more information on these items.

Table 6-16. ROM AC Specification (Sheet 1 of 2)

Symbols	Parameters	MIN	TYP	MAX	Units <sup>†</sup>	Notes
tromAS	Address setup to nCS assert	1	—	1	clk_mem	—
tromCES	nCS setup to nOE asserted	—	—	0	clk_mem	—
tromCEH	nCS hold from nOE deasserted	—	—	0	clk_mem	—
tromDSOH	MD setup to address valid	1.5	—	—	clk_mem	—

**Table 6-16. ROM AC Specification (Sheet 2 of 2)**

Symbols	Parameters	MIN	TYP	MAX	Units <sup>†</sup>	Notes
tromDOH	MD hold from address valid	0	—	—	clk_mem	—
tromAVDVF	Address valid to data valid for the first read access	2	MSCx[RDF]+2	32	clk_mem	—
tromAVDVS	Address valid to data valid for subsequent reads of non-burst devices	1	MSCx[RDF]+1	31	clk_mem	—
tflashAVDVS	Address valid to data valid for subsequent reads of burst devices	1	MSCx[RDN]+1	31	clk_mem	—
tromCD	nCS deasserted after a read of next nCS or nSDCS asserted (minimum)	1	MSCx[RRR]*2+ 1	15	clk_mem	—
<sup>†</sup> Numbers shown as integer multiples of the clk_mem period are ideal. Actual numbers vary with pin-to-pin differences in loading and transition direction (rise or fall). For more information, refer to the "Memory Control" chapter in the <i>Intel® PXA27x Processor Family Developer's Manual</i> .						

Figure 6-11. 32-Bit Non-burst ROM, SRAM, or Flash Read Timing

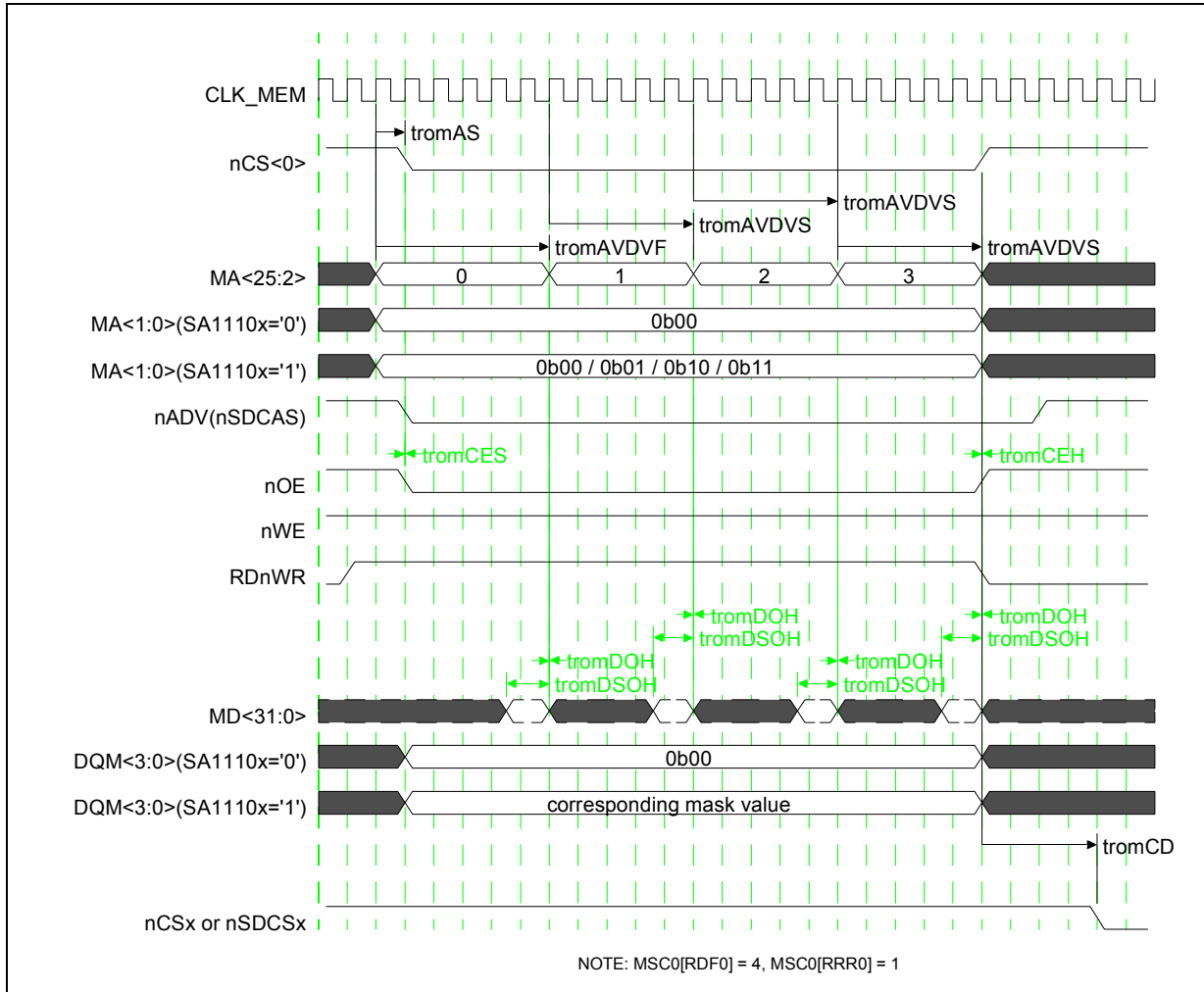



Figure 6-12. 32-Bit Burst-of-Eight ROM or Flash Read Timing

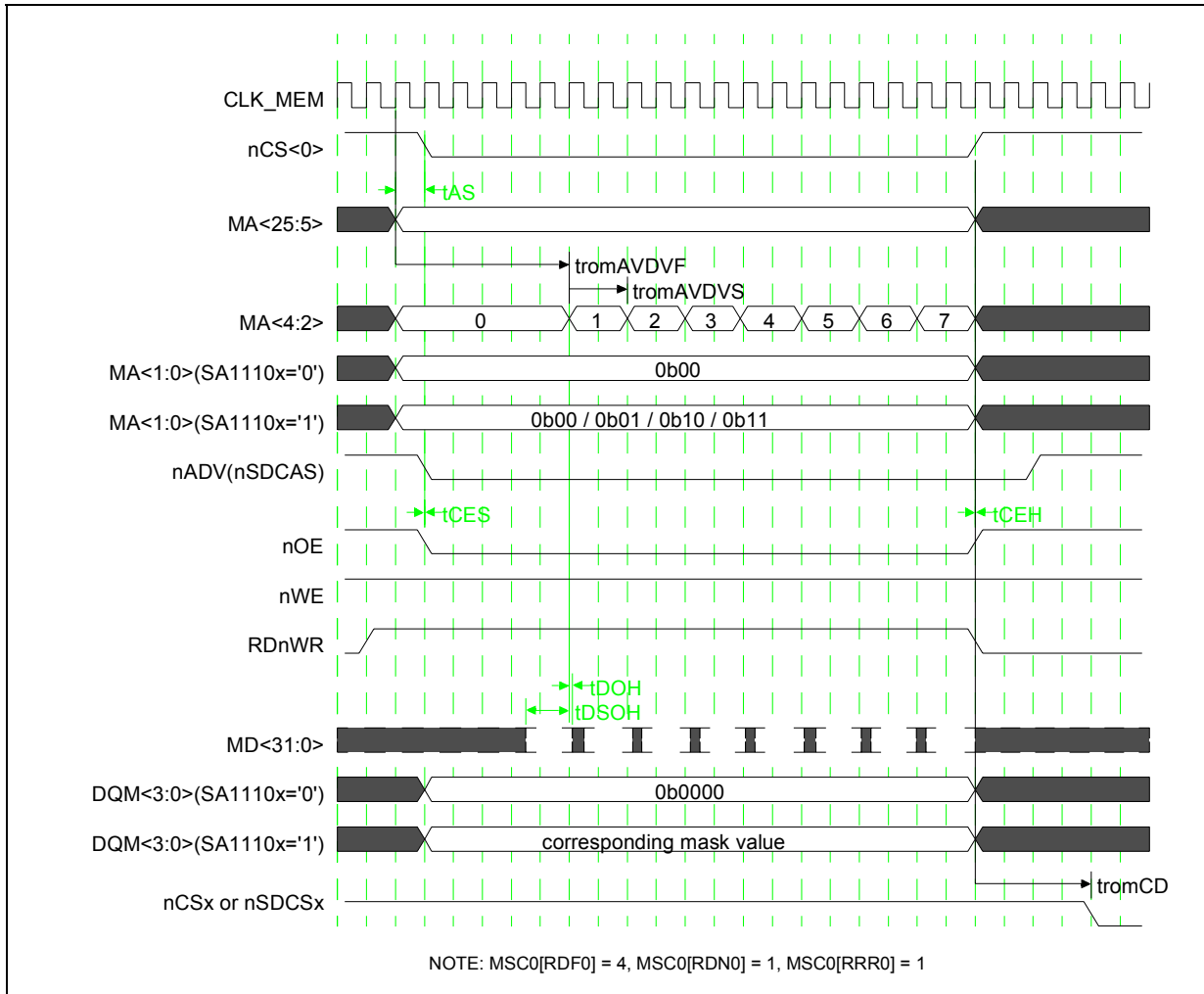

Figure 6-13. Eight-Beat Burst Read from 16-Bit Burst-of-Four ROM or Flash Timing

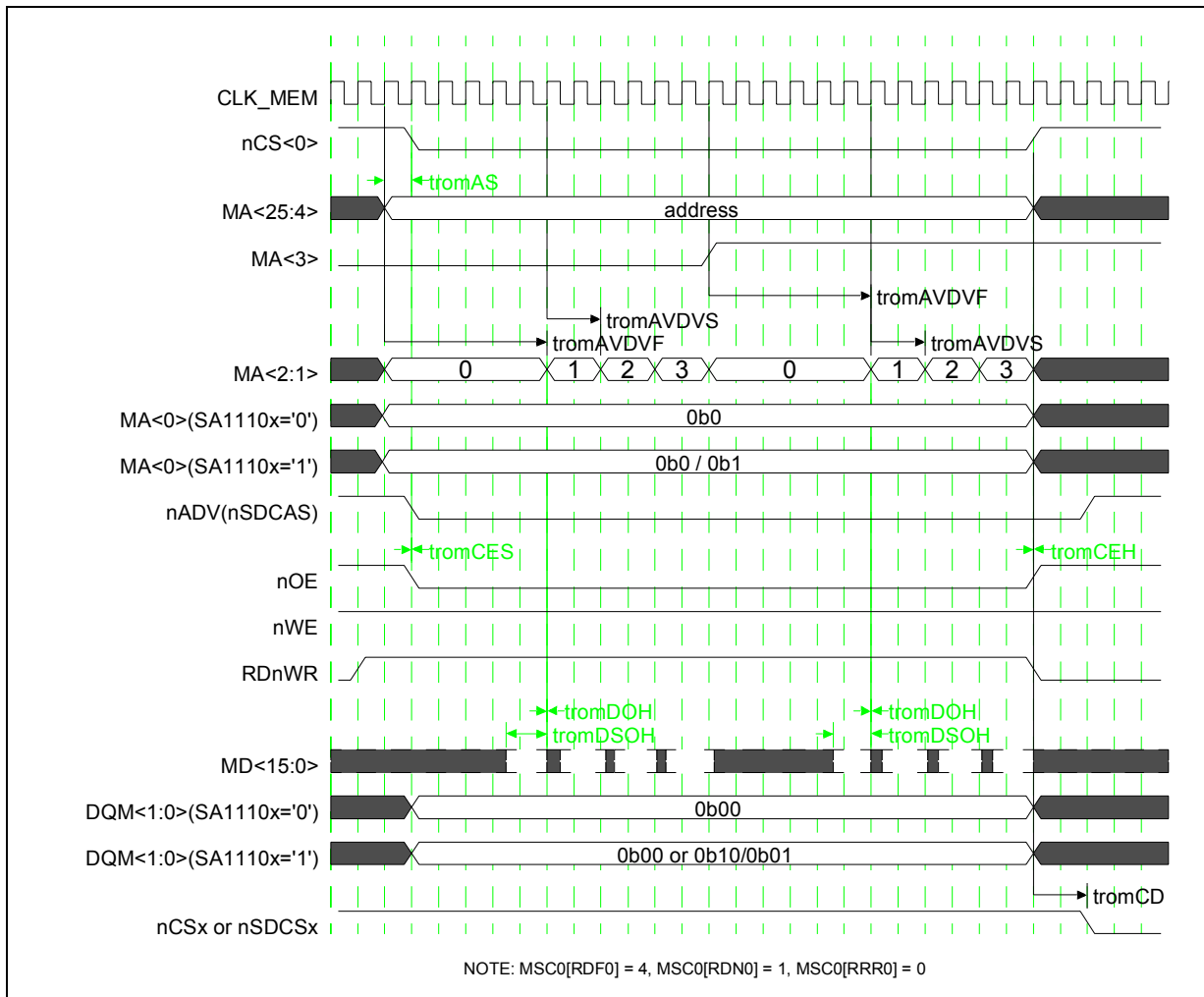
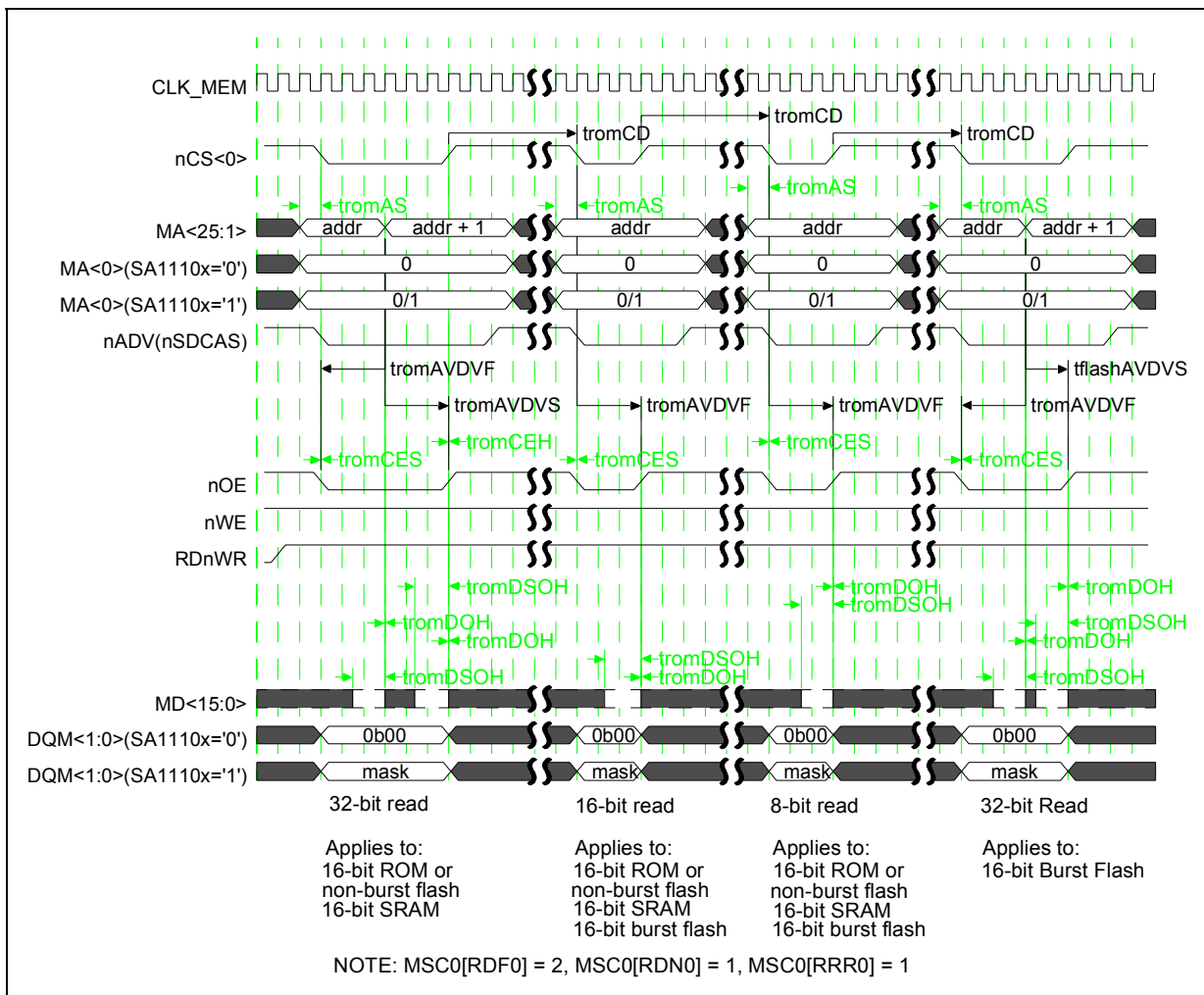

Figure 6-14. 16-bit ROM/Flash/SRAM Read for 4/2/1 Bytes Timing



## 6.4.4 Flash Memory Parameters and Timing Diagrams

The following sections describe the read/write parameters and timing diagrams for asynchronous and synchronous flash-memory interfaces with the memory controller.

### 6.4.4.1 Flash Memory Read Parameters and Timing Diagrams

Section 6.4.4.1.1 describes asynchronous flash reads. Section 6.4.4.1.2 describes synchronous flash reads.

#### 6.4.4.1.1 Asynchronous Flash Read Parameters and Timing Diagrams

The timings listed in Table 6-16 for ROM reads also apply to asynchronous flash reads. See Figure 6-11, Figure 6-12, Figure 6-13, and Figure 6-14 for timing diagrams representative of an asynchronous flash read.

## 6.4.4.1.2 Synchronous Flash Read Parameters and Timing Diagrams

Table 6-17 lists the timing parameters used in Figure 6-15, and, for flash packages, Figure 6-16.

Table 6-17. Synchronous Flash Read AC Specifications (Sheet 1 of 2)

Symbols	Parameters	MIN	TYP	MAX	MIN	TYP	MAX	MIN	TYP	MAX	Units	Notes
		Divide by 1 <sup>2</sup>			Divide by 2 <sup>3</sup>			Divide by 4 <sup>4</sup>				
tffCLK	SDCLK0 period	9.6	—	38.5	19.2	—	76.9	38.5	—	154	ns	1
tffAS	MA<25:0> setup to nSDCAS (as nADV) asserted	1	—	1	1	—	2	1	—	4	CLK_MEM	—
tffCES	nCS setup to nSDCAS (as nADV) asserted	1	—	1	1	—	2	1	—	4	CLK_MEM	—
tffADV	nSDCAS (as nADV) pulse width	1	—	1	3	—	3	7	—	7	CLK_MEM	—
tffOS	nSDCAS (as nADV) deassertion to nOE assertion	1	FCC – 1 (for FCC<5) FCC – 2 (for FCC>=5)	13	2	(FCC – 1) * 2 (for FCC<5) (FCC – 2) * 2 (for FCC>=5)	26	7	(FCC * 4) – 7 (for FCC<5) (FCC – 2) * 4 (for FCC>=5)	52	CLK_MEM	5
tffCEH	nOE deassertion to nCS deassertion	4	—	4	8	—	8	16	—	16	CLK_MEM	—
tffDS	CLK to data valid	2	FCC	15	2	FCC	15	2	FCC	15	CLK_MEM	5
		VCC_MEM = 1.8V +20% / -5% <sup>6</sup>			VCC_MEM = 2.5V +/- 10% <sup>7</sup>			VCC_MEM = 3.3V +/- 10% <sup>8</sup>				
tffSDOS	MA<25:0>, MD<31:0>, DQM<3:0>, nCS<3:0>, nSDCAS (nADV), nWE, nOE, RDnWR output setup time to SDCLK<2:1> rise	TBD	—	—	TBD	—	—	TBD	—	—	ns	—
tffSDOH	MA<25:0>, MD<31:0>, DQM<3:0>, nCS<3:0>, nSDCAS (nADV), nWE, nOE, RDnWR output hold time from SDCLK<2:1> rise	TBD	—	—	TBD	—	—	TBD	—	—	ns	—
		VCC_CORE = 0.85 V +/- 10%, with 1.71 V <= VCC_MEM <= 3.63 V			VCC_CORE = 1.1 V +/- 10%, with 1.71 V <= VCC_MEM <= 3.63 V			VCC_CORE = 1.3 V +/- 10%, with 1.71 V <= VCC_MEM <= 3.63 V				

**Table 6-17. Synchronous Flash Read AC Specifications (Sheet 2 of 2)**

Symbols	Parameters	MIN	TYP	MAX	MIN	TYP	MAX	MIN	TYP	MAX	Units	Notes
tffSDIS	MD<31:0> read data input setup time from SDCLK<2:0> rise	TBD	—	—	0.5	—	—	0.5	—	—	ns	—
tffSDIH	MD<31:0> read data input hold time from SDCLK<2:0> rise	TBD	—	—	1.8	—	—	1.8	—	—	ns	—

**NOTES:**

- SDCLK0 may be configured to be CLK\_MEM divided by 1, 2 or 4. SDCLK0 for synchronous flash memory can be at the slowest, divide-by-4 of the 26-MHz CLK\_MEM. The fastest possible SDCLK0 is accomplished by configuring CLK\_MEM at 104 MHz and clearing the MDREFR[K0DB2] or MDREFR[K0DB4] bit fields.
- SDCLK0 frequency equals CLK\_MEM frequency (MDREFR[K0DB4] and MDREFR[K0DB2] bit fields are clear)
- SDCLK0 frequency equals CLK\_MEM/2 frequency (MDREFR[K0DB2] is set and MDREFR[K0DB4] is clear).
- SDCLK0 frequency equals CLK\_MEM/4 frequency (MDREFR[K0DB4] is set).
- Use SXCNFG[SXCLx] to configure the value for the frequency configuration code (FCC).
- These numbers are for VCC\_MEM = 1.8 V +20% / -5%, VOL = 0.4 V, and VOH = 1.4 V, with each applicable 4-bit field of the system memory buffer strength registers (BSCN TRP and BSCNTRN) set to TBD (msb:lsb) and each applicable SDCLK0 divide-by-2 and divide-by-4 register bits (MDREFR[K0DB2] and MDREFR[K0DB4]) clear. If MDREFR[K0DB2] is set, the corresponding output setup and hold times are increased and decreased, respectively, by 0.25 times the SDCLK0 period.
- These numbers are for VCC\_MEM = 2.5 V +/- 10%, VOL = 0.4 V, and VOH = 2.1 V, with each applicable 4-bit field of the system memory buffer strength registers (BSCNTRP and BSCNTRN) set to 0b1010 (msb:lsb) and each applicable SDCLK0 divide-by-2 and divide-by-4 register bit (MDREFR[K0DB2] and MDREFR[K0DB4]) clear. If MDREFR[K0DB2] is set, the corresponding output setup and hold times are increased and decreased, respectively, by 0.25 times the SDCLK0 period.
- These numbers are for VCC\_MEM = 3.3 V +/- 10%, VOL = 0.4 V, and VOH = 2.4 V, with each applicable 4-bit field of the system memory buffer strength registers (BSCNTRP and BSCNTRN) set to 0b1010 (msb:lsb) and each applicable SDCLK0 divide-by-2 and divide-by-4 register bit (MDREFR[K0DB2] and MDREFR[K0DB4]) clear. If MDREFR[K0DB2] is set, the corresponding output setup and hold times are increased and decreased, respectively, by 0.25 times the SDCLK0 period.

Figure 6-15. Synchronous Flash Burst-of-Eight Read Timing

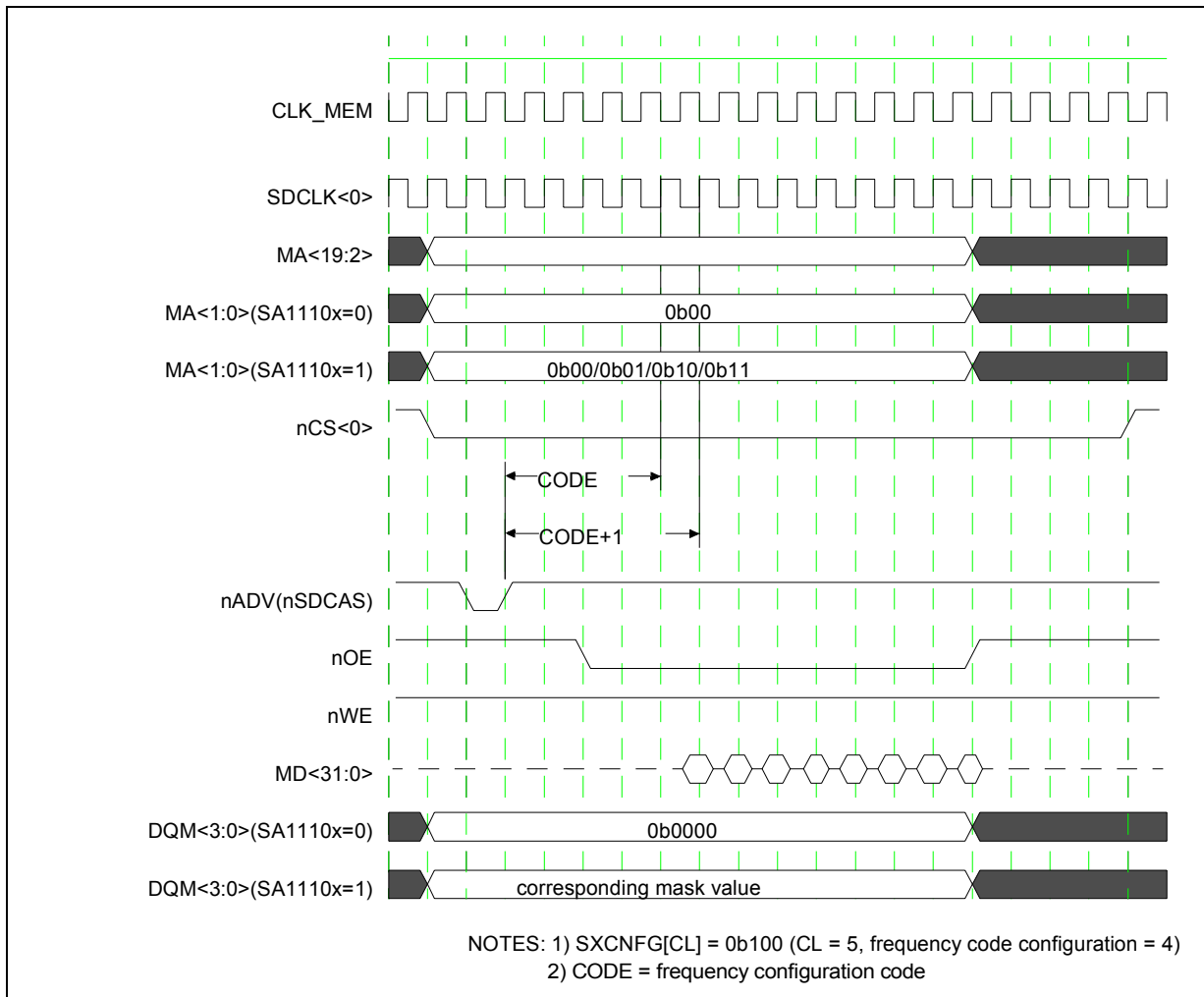

Figure 6-16. Synchronous Flash Stacked Burst-of-Eight Read Timing

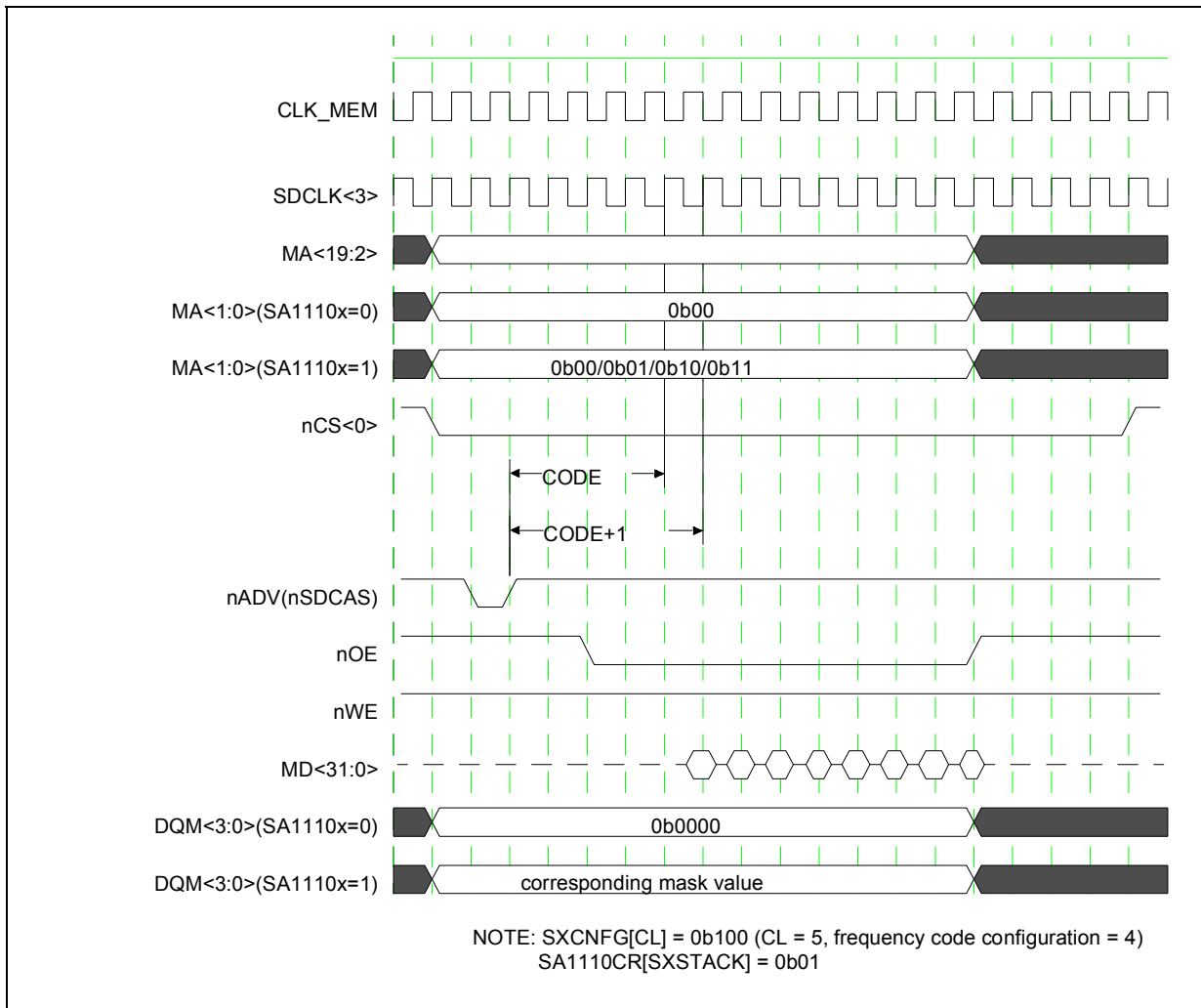
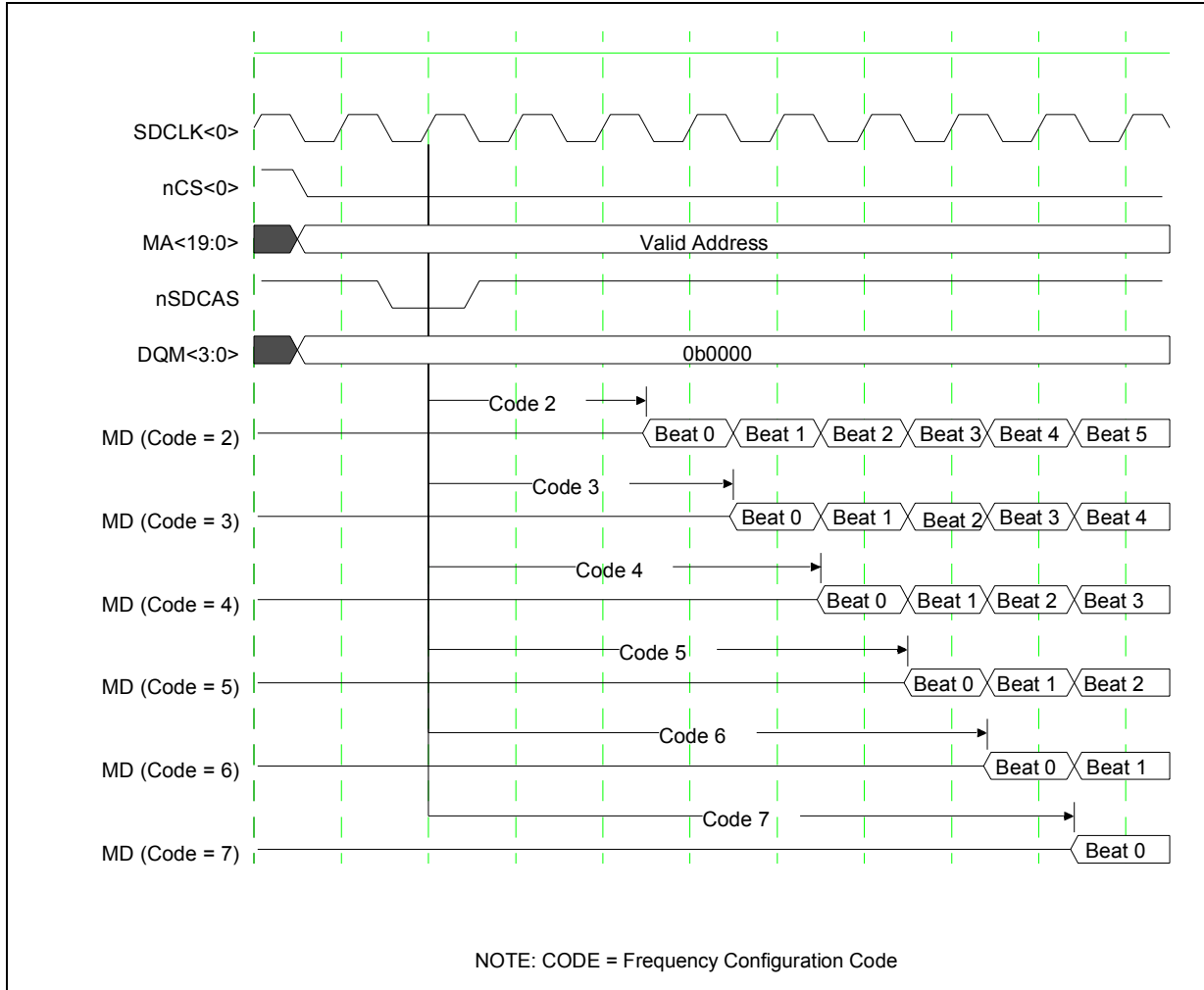

Figure 6-17 indicates which clock data would be latched following the assertion of nSDCAS(ADV), depending on the configuration of the SXCNFG[SXCLx] bit field. The period in the diagram indicated by different frequency configuration codes (Fcodes or FCCs) is equal to the number of SDCLK0 cycles between the READ command and the clock edge on which data is driven onto the bus.

Figure 6-17. First-Access Latency Configuration Timing







The burst read example shown in [Figure 6-18](#) represents waveforms that result when `SXCNFG[SXCLx]` is configured as `0b0100`, representing a frequency configuration code equal to 3. The following example can be used to help determine the appropriate setting for `SXCNFG[SXCLx]`.

Parameters defined by the processor:

- $t_{ffSDOH}(\text{max}) = \text{SDCLK}\langle 0 \rangle$  to  $\text{CE}\#$  ( $n_{\text{CE}}$ ),  $\text{ADV}\#$  ( $n_{\text{ADV}}$ ), or address valid, whichever occurs last
- $t_{ffSDIS}(\text{min}) = \text{Data setup to SDCLK}\langle 0 \rangle$

Parameters defined by flash memory:

- $t_{VLQV}(\text{min}) = \text{ADV}\#$  low to output delay
- $t_{VLCH}(\text{min}) = \text{ADV}\#$  low to clock
- $t_{CHQV}(\text{max}) = \text{SDCLK}\langle 0 \rangle$  to output valid

Use the following equations when calculating the frequency configuration code:

- (1)  $\text{SDCLK period} = (1 / \text{frequency})$
- (2)  $n(\text{SDCLK period}) \geq t_{VLQV} - t_{VLCH} - t_{CHQV}$
- (3)  $n = (t_{VLQV} - t_{VLCH} - t_{CHQV}) / \text{SDCLK period}$ , where  
 $n = \text{frequency configuration code rounded up to integer value}$
- (4)  $\text{SDCLK period} \geq t_{CHQV} + t_{ffSDIS}$

### Example

The timing information below is only an example. See [Table 6-17](#) for actual synchronous AC timings.

```

SDCLK<0> frequency = 50 MHz
tVLQV = 70 ns (typical timing from synchronous flash memory)
tVLCH = 10 ns (min)
tCHQV = 14 ns (min)
From Eq. (1):      1 / 50 (MHz) = 20 ns
From Eq. (2):      n(20 ns) ≥ 70 ns - 10 ns - 14 ns
                   n(20 ns) ≥ 46 ns
                   n = (46 / 20) ns = 2.3 ns
                   n = 3

```

Use equation 4 to help verify the maximum possible frequency at which the synchronous flash memory can run with the memory controller. The following example uses equation 4:

```

SDCLK<0> frequency = 66 MHz
tCHQV = 11 ns (max)
tffSDIS = 3 ns (min)
From Eq. (1):      1 / 66 (MHz) = 15.15 ns
From Eq. (4):      15.15 ns ≥ 11 ns + 3 ns
                   15.15 ns ≥ 14 ns

```

The results from this example indicate that the 66-MHz memory works without problems with the memory controller.

**Note:** All AC timings must be considered to avoid timing violations in the memory-to-memory-controller interface.

Figure 6-18. Synchronous Flash Burst Read Example

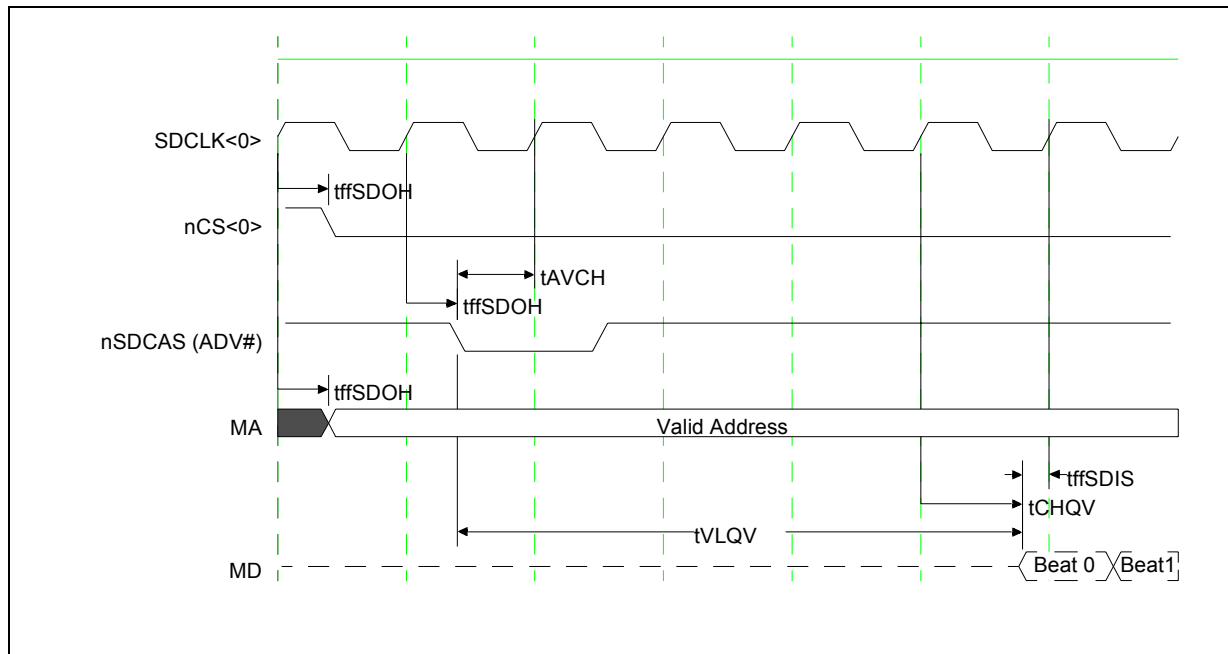

#### 6.4.4.2 Flash Memory Write Parameters and Timing Diagrams

Table 6-18 lists the AC specification for both burst and non-burst flash writes shown in Figure 6-19 and, for stacked flash packages, Figure 6-20.

Table 6-18. Flash Memory AC Specification (Sheet 1 of 2)

Symbols	Parameters	MIN	TYP	MAX	Units <sup>1</sup>	Notes
tflashAS	Address setup to nCS assert	1	—	1	clk_mem	—
tflashAH	Address hold from nWE de-asserted	1	—	1	clk_mem	—
tflashASW	Address setup to nWE asserted	1	—	3	clk_mem	2
tflashCES	nCS setup to nWE asserted	2	—	2	clk_mem	—
tflashCEH	nCS hold from nWE de-asserted	1	—	1	clk_mem	—
tflashWL	nWE asserted time	1	MSCx[RDF]+1	31	clk_mem	—
tflashDSWH	MD/DQM setup to nWE de-asserted	2	MSCx[RDF]+2	32	clk_mem	—
tflashDH	MD/DQM hold from nWE de-asserted	1	—	1	clk_mem	—
tflashDSOH	MD setup to address valid	1.5	—	—	clk_mem	—

Table 6-18. Flash Memory AC Specification (Sheet 2 of 2)

Symbols	Parameters	MIN	TYP	MAX	Units <sup>1</sup>	Notes
tflashDOH	MD hold from address valid	0	—	—	clk_mem	—
tflashCD	nCS de-asserted after a read/write to next nCS or nSDCS asserted (minimum)	1	$MSCx[RRR]*2 + 1$	15	clk_mem	—

**NOTES:**

- Numbers shown as integer multiples of the CLK\_MEM period are ideal. Actual numbers vary with pin-to-pin differences in loading and transition direction (rise or fall).
- On the first data beat of burst transfer, the tflashASW is 3 CLK\_MEM periods. On subsequent data beats, the tflashASW is 1 CLK\_MEM period.

Figure 6-19. 32-Bit Flash Write Timing

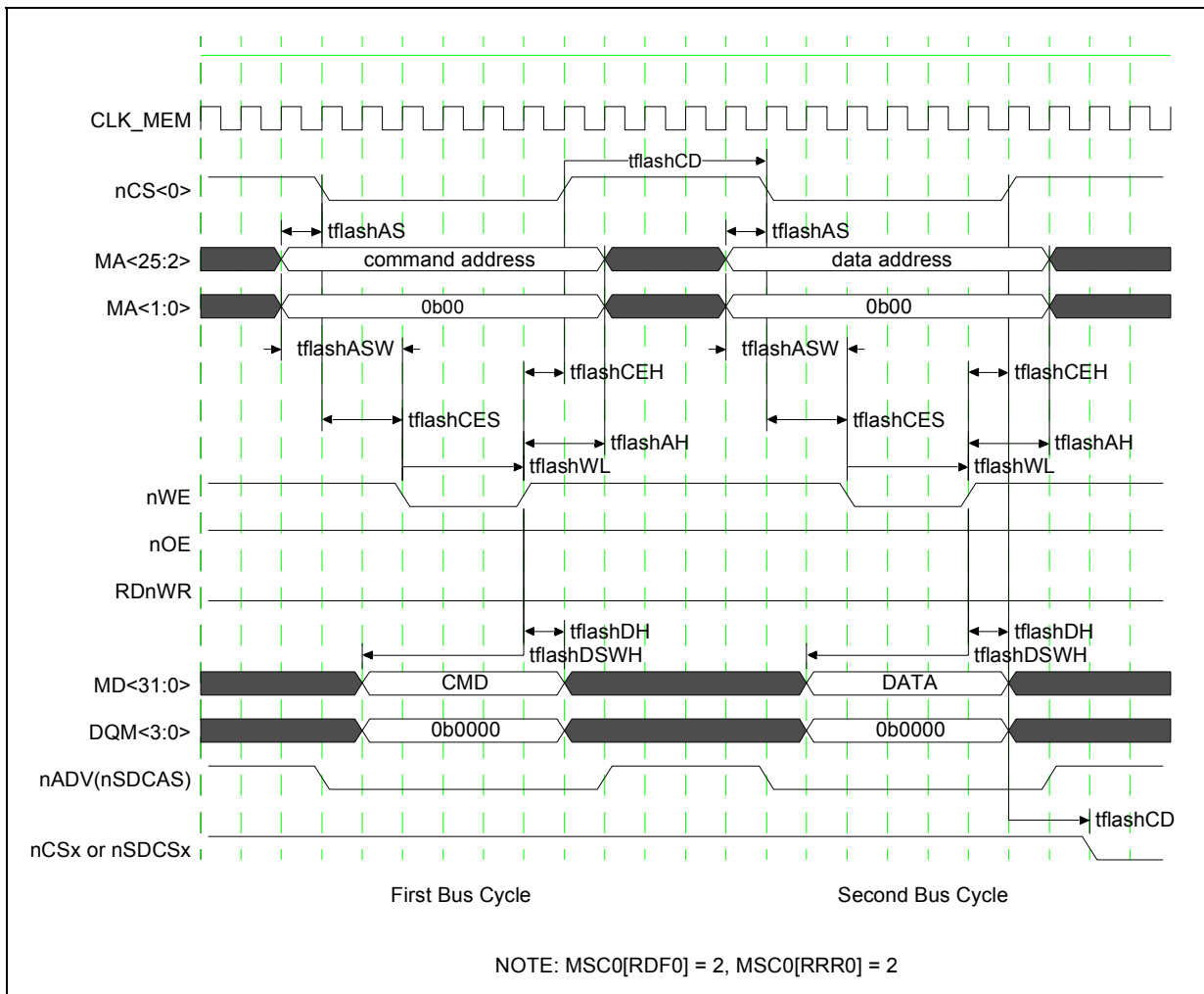
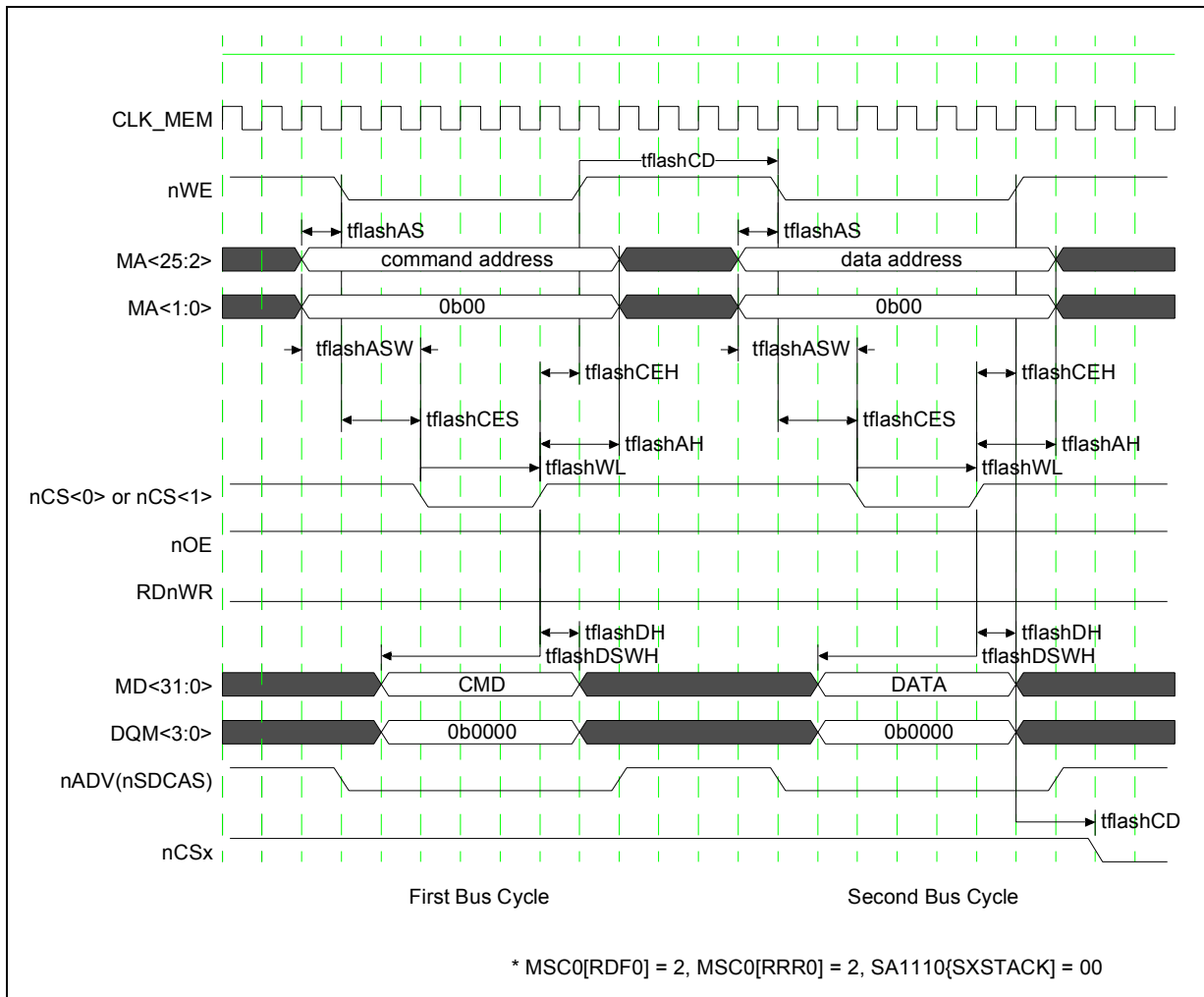
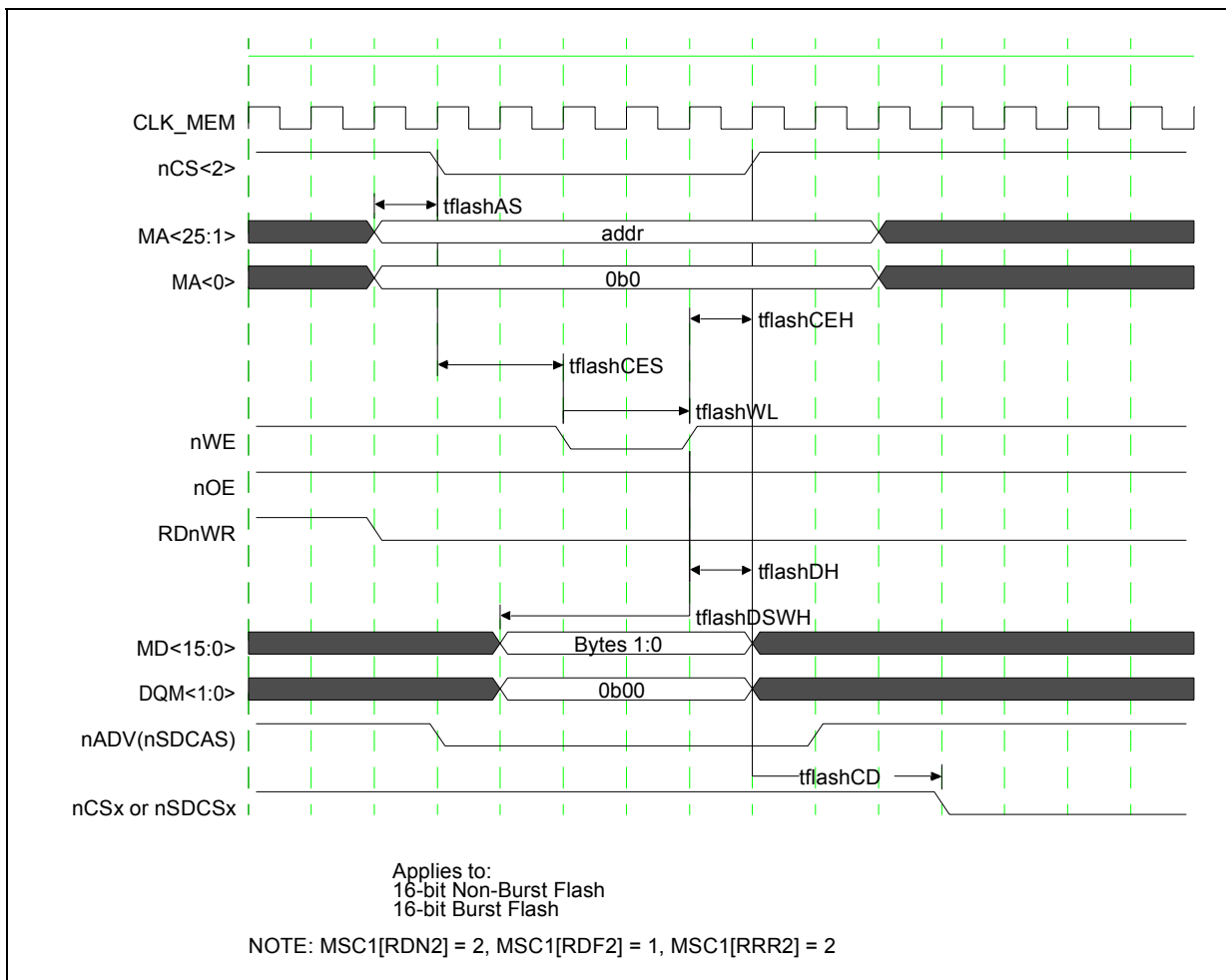

Figure 6-20. 32-Bit Stacked Flash Write Timing



**Figure 6-21. 16-Bit Flash Write Timing**

## 6.4.5 SRAM Parameters and Timing Diagrams

The following sections describe the read/write parameters and timing diagrams for SRAM interfaces with the memory controller.

### 6.4.5.1 SRAM Read Parameters and Timing Diagrams

The timing for a read access is identical to that for a non-burst ROM read (see Figure 6-11). The timings listed in Table 6-16 for ROM reads are also used for SRAM reads. See Figure 6-11 and Figure 6-14 for timings diagrams representing 16-bit SRAM transferring four, two, and one byte(s) during read-bus tenures.

### 6.4.5.2 SRAM Write Parameters and Timing Diagrams

Figure 6-22 and Figure 6-23 show the timing for 32-bit and 16-bit SRAM writes. Table 6-19 lists the timings used in Figure 6-22 and Figure 6-23.



During writes, data pins are actively driven by the processor and are not three-stated, regardless of the states of the individual DQM signals. For SRAM writes, the DQM signals are used as byte enables.

**Note:** Table 6-19 lists programmable register items. See the “Memory Controller” chapter in the *Intel® PXA27x Processor Family Developer’s Manual* for register configurations for more information on these items.

**Table 6-19. SRAM Write AC Specification**

Symbols	Parameters	MIN	TYP	MAX	Units <sup>1</sup>	Notes
tsramAS	Address setup to nCS assert	1	—	1	clk_mem	—
tsramAH	Address hold from nWE de-asserted	1	—	1	clk_mem	—
tsramASW	Address setup to nWE asserted	1	—	3	clk_mem	2
tsramCES	nCS setup to nWE asserted	2	—	2	clk_mem	—
tsramCEH	nCS hold from nWE de-asserted	1	—	1	clk_mem	—
tsramWL	nWE asserted time	1	MSCx[RDN]+1	31	clk_mem	—
tsramDSWH	MD/DQM setup to nWE de-asserted	2	MSCx[RDN]+2	32	clk_mem	—
tsramDH	MD/DQM hold from nWE de-asserted	1	—	1	clk_mem	—
tsramCD	nCS de-asserted after a read to next nCS or nSDCS asserted (minimum)	1	MSCx[RRR]*2+1	15	clk_mem	—

**NOTES:**

- Numbers shown as integer multiples of the CLK\_MEM period are ideal. Actual numbers vary with pin-to-pin differences in loading and transition direction (rise or fall).
- On the first data beat of burst transfer, the tsramASW is 3 CLK\_MEM periods. On subsequent data beats, the tsramASW is 1 CLK\_MEM period.

Figure 6-22. 32-Bit SRAM Write Timing

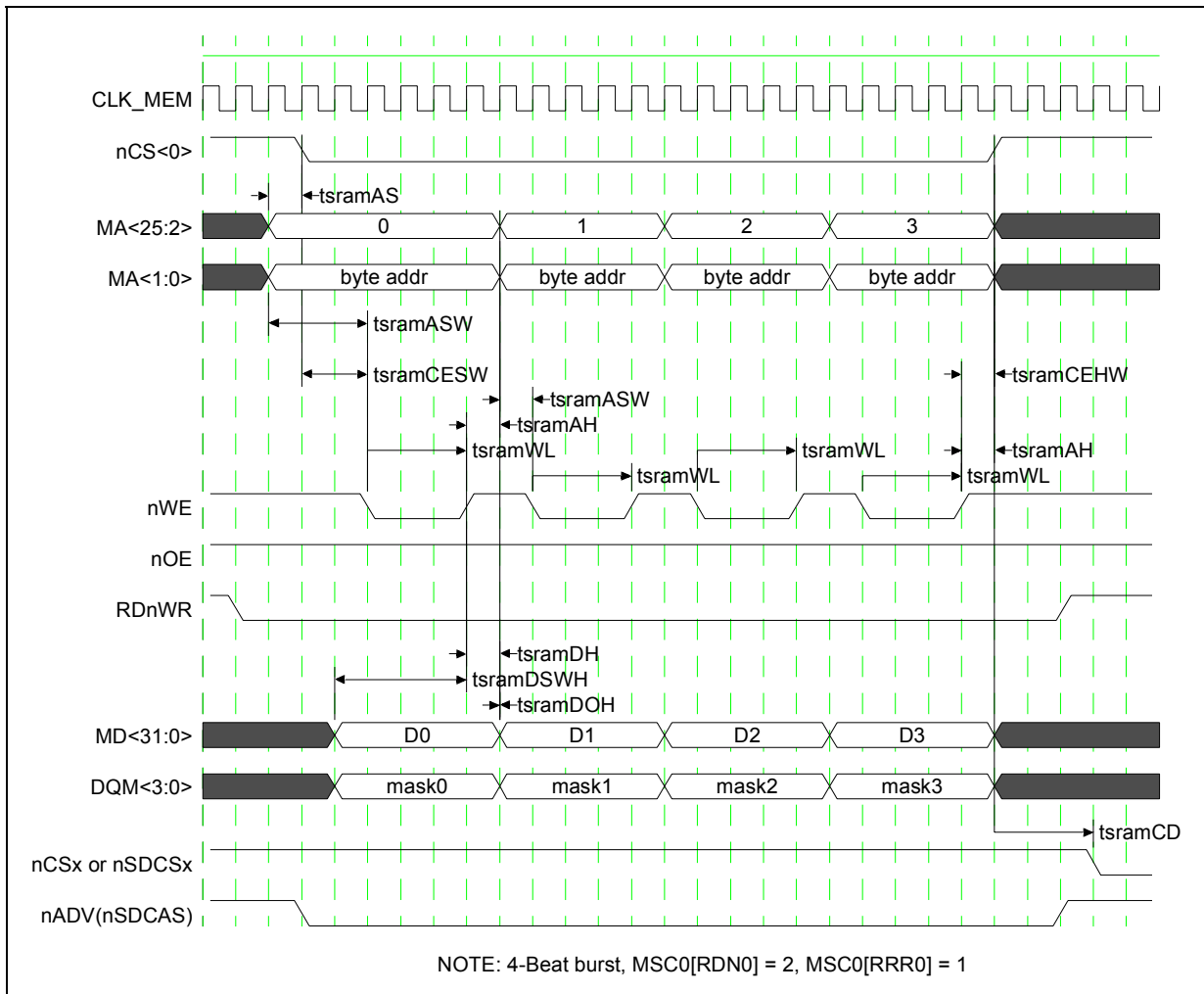
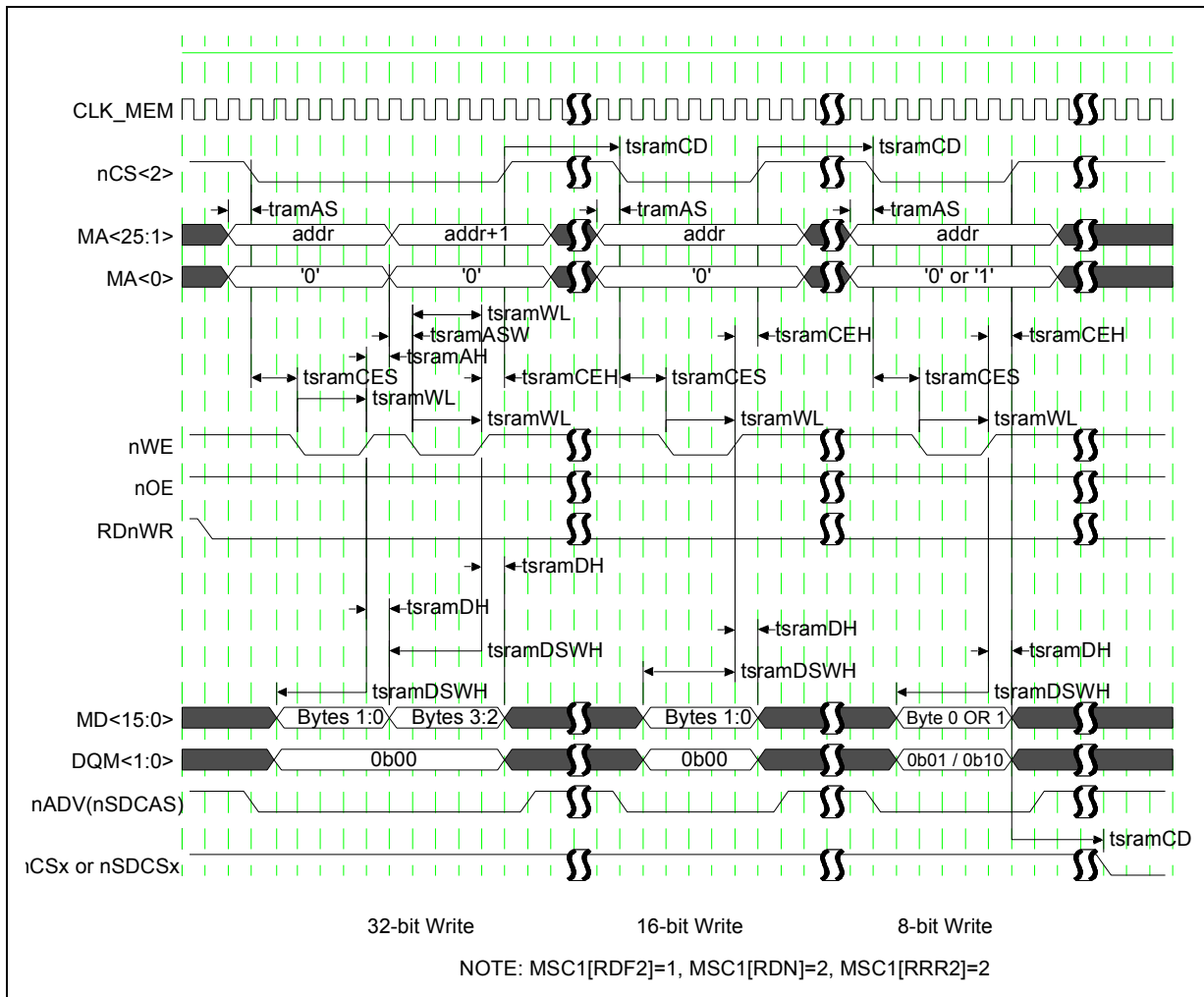

Figure 6-23. 16-bit SRAM Write for 4/2/1 Byte(s) Timing



### 6.4.6 Variable-Latency I/O Parameters and Timing Diagrams

The following sections describe the read/write parameters and timing diagrams for VLIO memory interfaces with the memory controller.

Table 6-20 lists the timing-information references for both the read and the write timing diagrams.

**Note:** Table 6-20 lists programmable register items. For more information on these items, see the “Memory Controller” chapter in the Intel® PXA27x Processor Family Developer’s Manual for register configurations.



**Table 6-20. VLIO Timing**

Symbols	Parameters	MIN	TYP	MAX <sup>2</sup>	Units <sup>1</sup>	Notes
tvlioAS	Address setup to nCS asserted	1	—	1	clk_mem	—
tvlioAH	Address hold from nPWE/nOE de-asserted	2	MSCx[RDN]	30	clk_mem	—
tvlioASRW0	Address setup to nPWE/nOE asserted (1st access)	3	—	3	clk_mem	—
tvlioASRWn	Address setup to nPWE/nOE asserted (next access(es))	2	MSCx[RDN]	30	clk_mem	—
tvlioCES	nCS setup to nPWE/nOE asserted	2	—	2	clk_mem	—
tvlioCEH	nCS hold from nPWE/nOE de-asserted	1	—	1	clk_mem	—
tvlioDSWH	MD/DQM setup (minimum) to nPWE de-asserted	5	MSCx[RDF]+2	32	clk_mem	—
tvlioDH	MD/DQM hold from nPWE de-asserted	1	—	1	clk_mem	—
tvlioDSOH	MD setup to address changing	1.5	—	—	clk_mem	—
tvlioDOH	MD hold from address changing	0	—	—	ns	—
tvlioRDYH	RDY hold from nPWE/nOE de-asserted	0	—	—	ns	—
tvlioRWA	nPWE/nOE assert period between writes	4	MSC[RDF]+1 + Waits	31 + Waits	clk_mem	—
tvlioRWD	nPWE/nOE de-asserted period between writes	4	MSCx[RDN]*2]	60	clk_mem	3
tvlioCD	nCS de-asserted after a read/write to next nCS or nSDCS asserted (minimum)	1	MSCx[RRR]*2 + 1	15	clk_mem	—

**NOTES:**

1. Numbers shown as integer multiples of the CLK\_MEM period are ideal. Actual numbers vary with pin-to-pin differences in loading and transition direction (rise or fall).
2. Maximum values reflect the register dynamic ranges.
3. Depending on the programmed value of MSC[RDN] and the clk\_mem speed, this can be a significant amount of time. Processor does not drive the data bus during this time between transfers. If the VLIO does not drive the data bus during this time between transfers, the data bus is not driven for this period of time. If MSC[RDN] is programmed to 60 (which equals 60 CLK\_MEM cycles), then the data bus could potentially not be driven for 30\*2 = 60 CLK\_MEM cycles.

### 6.4.6.1 Variable Latency I/O Read Timing

Figure 6-24 shows the timing for 32-bit variable-latency I/O (VLIO) memory reads. Table 6-20 lists the timing parameters used in these diagrams.



Figure 6-24. 32-Bit VLIO Read Timing

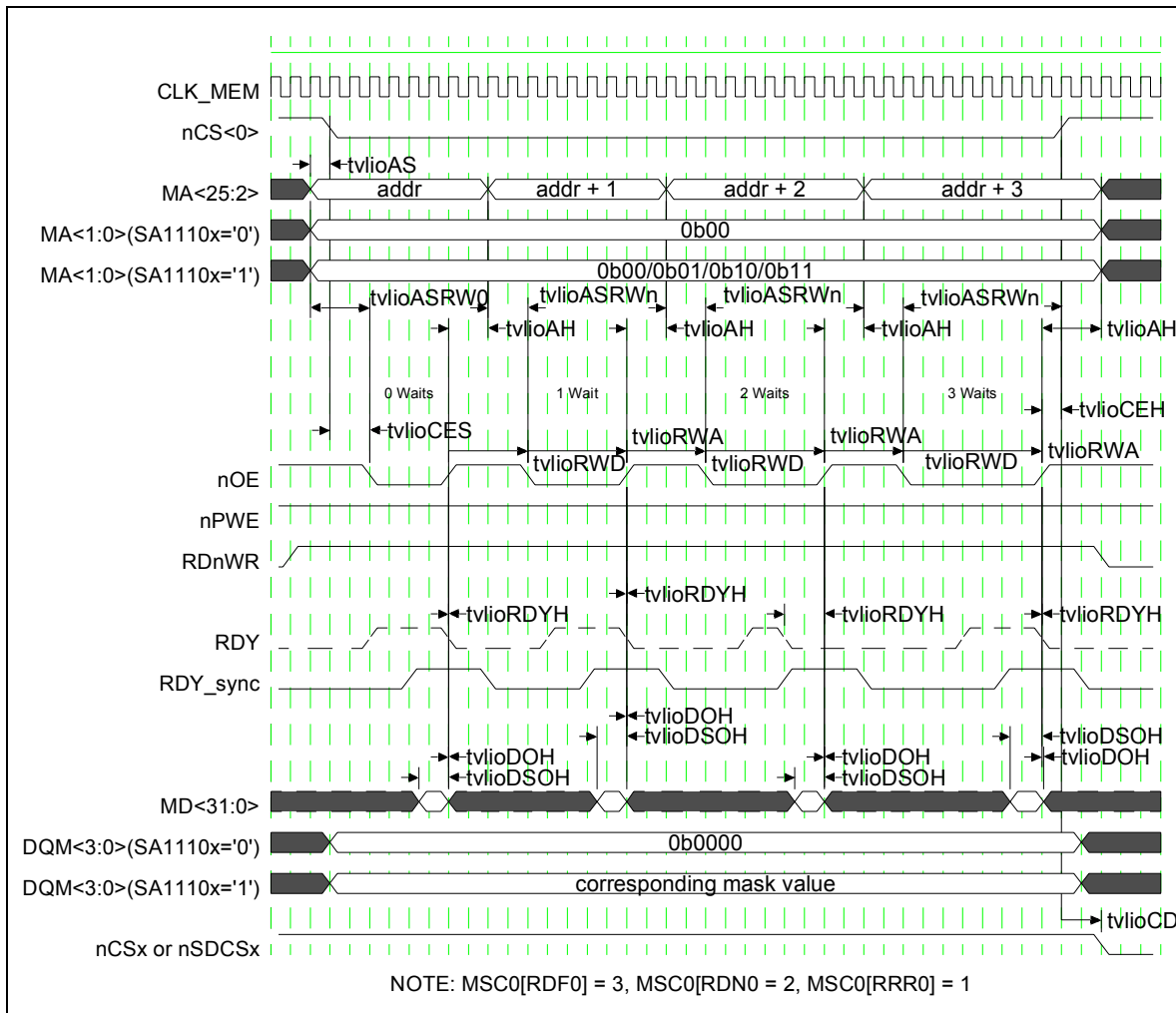

#### 6.4.6.2 Variable-Latency I/O Write Timing

Figure 6-25 shows the timing for 32-bit VLIO memory writes. Table 6-20 lists the timing parameters used in Figure 6-25.

Figure 6-25. 32-Bit VLIO Write Timing

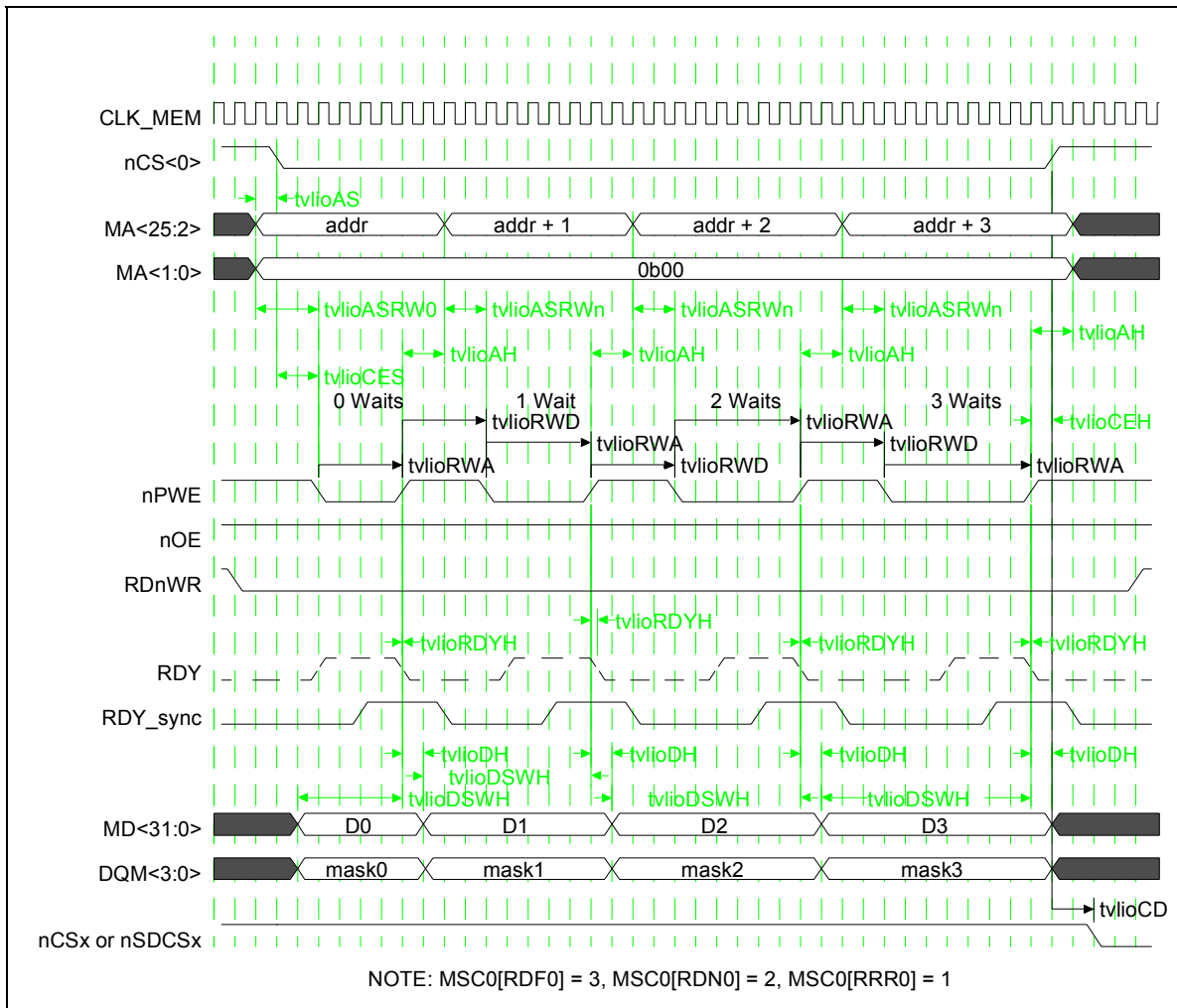

## 6.4.7 Expansion-Card Interface Parameters and Timing Diagrams

The following sections describe the read/write parameters and timing diagrams for CompactFlash\* and PC Card\* (expansion card) memory interfaces with the memory controller.

Table 6-21 shows the timing parameters used in the timing diagrams, Figure 6-26 and Figure 6-27.

**Note:** Table 6-21 lists programmable register items. See the “Memory Controller” chapter in the *Intel® PXA27x Processor Family Developer’s Manual* for register configurations for more information on these items.

**Table 6-21. Expansion-Card Interface AC Specifications**

Symbols	Parameters	MIN	TYP	MAX	Units	Notes
tcdAVCL	Address Valid to CMD Low	2	MCx[SET]	127	CLK_MEM	1,2,3,4
tcdCHAI	CMD High to Address Invalid	0	MCx[HOLD]	63	CLK_MEM	1,2,3,5
tcdDVCL	Write Data Valid to CMD Low	—	1	—	CLK_MEM	1,3
tcdCHWDI	CMD High to Write Data Invalid	—	4	—	CLK_MEM	1,3
tcdDVCH	Read Data Valid to CMD High	2	—	—	CLK_MEM	1,3
tcdCHRDI	CMD High to Read Data Invalid	0	—	—	ns	3
tcdCMD	CMD Assert During Transfers	—	tcdCLPS + tcdPHCH + nPWAIT assertion	—	CLK_MEM	1,3
tcdILCL	nIOIS16 Low to CMD Low	4	—	—	CLK_MEM	1,3
tcdCHIH	CMD High to nIOIS16 High	2	—	—	CLK_MEM	1,3
tcdCLPS	CMD Low to nPWAIT Sample	—	x_ASST_WAIT	—	CLK_MEM	1,3,6,7
tcdPHCH	nPWAIT High to CMD High	—	x_ASST_HOLD	—	CLK_MEM	1,3,6,8

**NOTES:**

- All numbers shown are ideal, integer multiples of the CLK\_MEM period. Actual numbers vary with pin-to-pin differences in loading and transition direction (rise or fall).
- Includes signals MA[25:0], nPREG, and nPSKTSEL.
- CMD refers to signals nPWE, nPOE, nPIOW, and nPIOR
- Refer to the *Intel® PXA27x Processor Family Developer’s Manual*, Expansion Memory Timing Configuration registers to change the assertion of CMD using the MCx[SET] bit fields.
- Refer to the *Intel® PXA27x Processor Family Developer’s Manual*, Expansion Memory Timing Configuration registers to increase the assertion of CMD using the MCx[HOLD] bit fields.
- Refer to the *Intel® PXA27x Processor Family Developer’s Manual*, Expansion Memory Timing Configuration registers to increase timings. The timings are changed by programming the MCx[ASST] respective bit fields. Refer to the PC Card Interface Command Assertion Code table to see the effect of MCx[ASST].
- tcdCLPS equals CLK\_MEM \* x\_ASST\_WAIT. Refer to the PC Card Interface Command Assertion Code table in the *Intel® PXA27x Processor Family Developer’s Manual* for the correlation between x\_ASST\_WAIT and the MCx[ASST] bit field.
- tcdPHCH equals CLK\_MEM \* x\_ASST\_HOLD. Refer to the PC Card Interface Command Assertion Code table in the *Intel® PXA27x Processor Family Developer’s Manual* for the correlation between x\_ASST\_HOLD and the MCx[ASST] bit field.

Figure 6-26. Expansion-Card Memory or I/O 16-Bit Access Timing

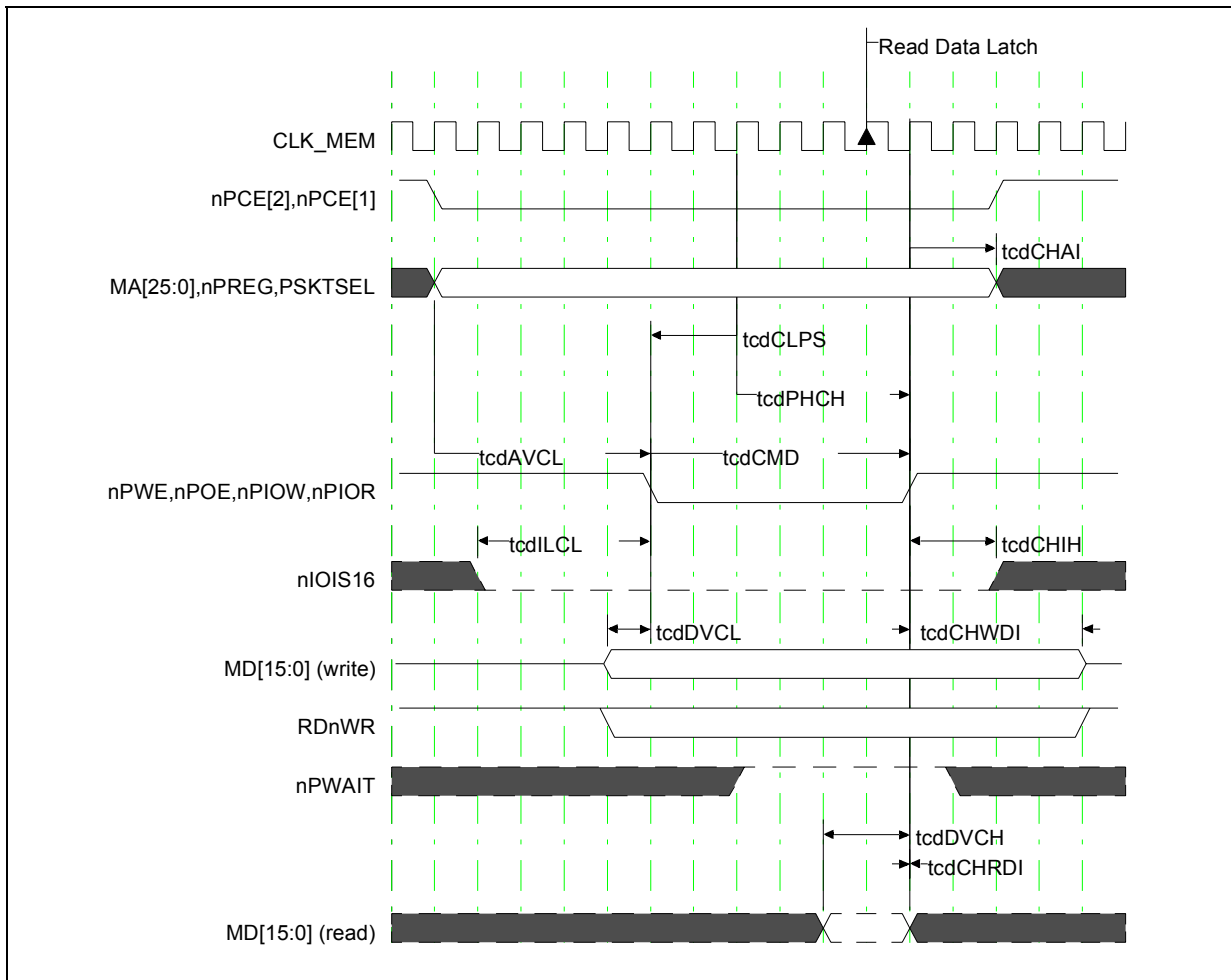
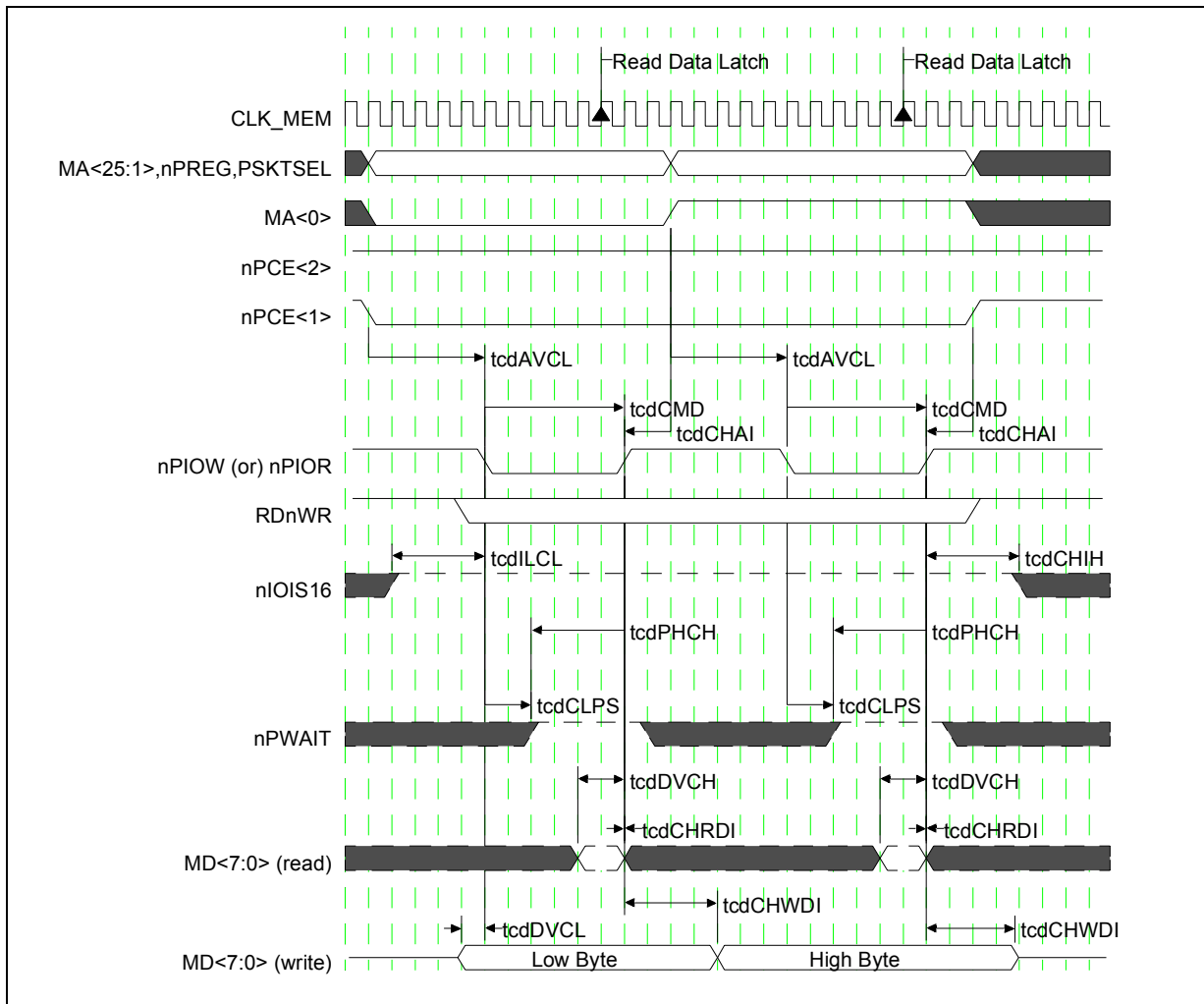

Figure 6-27. Expansion-Card Memory or I/O 16-Bit Access to 8-Bit Device Timing



## 6.5 LCD Timing Specifications

Figure 6-28 describes the LCD timing parameters. The LCD pin timing specifications are referenced to the pixel clock (L\_PCLK\_WR). Table 6-22 gives the values for the parameters.

**Figure 6-28. LCD Timing Definitions**

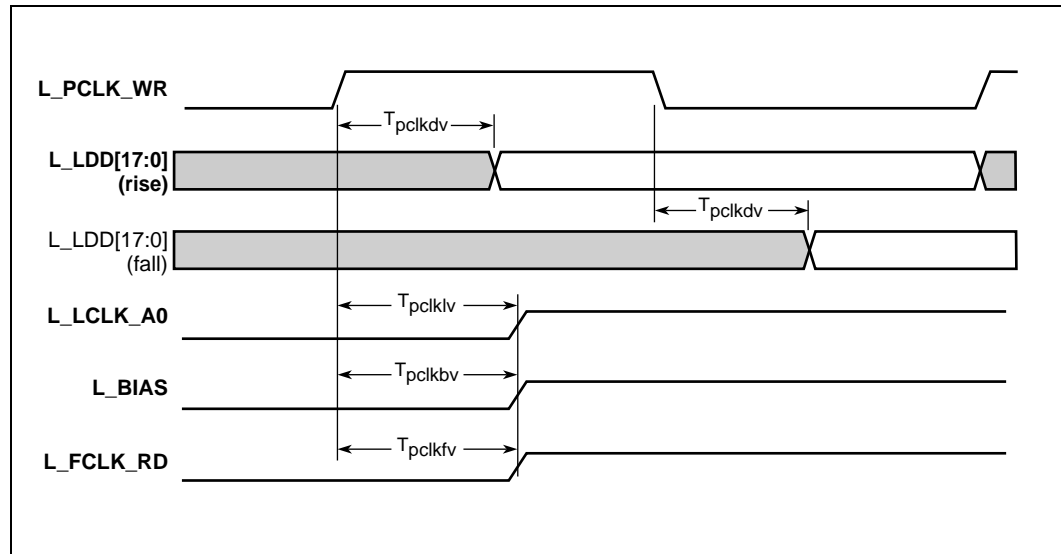

**Table 6-22. LCD Timing Specifications**

Symbol	Description	Min	Max	Units	Notes
T <sub>pclkdv</sub>	L_PCLK_WR rise/fall to L_LDD<17:0> driven valid	—	14	ns	1
T <sub>pcklv</sub>	L_PCLK_WR fall to L_LCLK_A0 driven valid	—	14	ns	2
T <sub>pckfv</sub>	L_PCLK_WR fall to L_FCLK_RD driven valid	—	14	ns	2
T <sub>pckbv</sub>	L_PCLK_WR rise to L_BIAS driven valid	—	14	ns	2

**NOTES:**

1. The LCD data pins can be programmed to be driven on either the rising or falling edge of the pixel clock (L\_PCLK\_WR).
2. These LCD signals can toggle when L\_PCLK\_WR is not clocking (between frames). At this time, they are clocked with the internal version of the pixel clock before it is driven out onto the L\_PCLK\_WR pin.

## 6.6 SSP Timing Specifications

Figure 6-29 describes the SSP timing parameters. The SSP pin timing specifications are referenced to SSPCLK. Table 6-23 gives the values for the parameters.

**Note:** In Figure 6-29, read the term “t<sub>SFMV</sub>” as “TSTXV.”

Figure 6-29. SSP Master Mode Timing Definitions

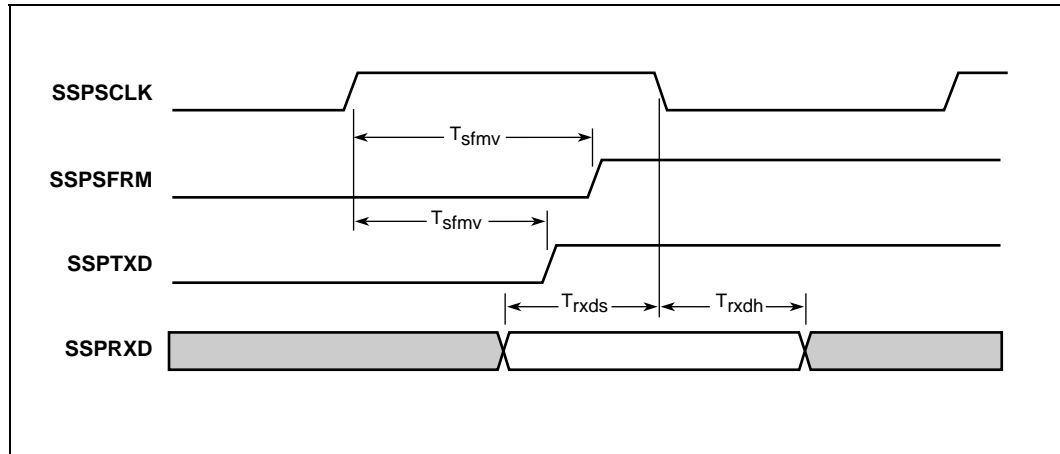

Table 6-23. SSP Master Mode Timing Specifications

Symbol	Description	Min	Max	Units	Notes
Tsfmv	SSPCLK rise to SSPSRM driven valid		21	ns	
Trxds	SSPRXD valid to SSPCLK fall (input setup)	11		ns	
Trxdh	SSPCLK fall to SSPRXD invalid (input hold)	0		ns	
Tsfmv	SSPCLK rise to SSPTXD valid		22	ns	

Figure 6-30. Timing Diagram for SSP Slave Mode Transmitting Data to an External Peripheral

PXA27x processor transmitting data

PXA27x SSP (Slave Mode) transmitting data to external peripheral

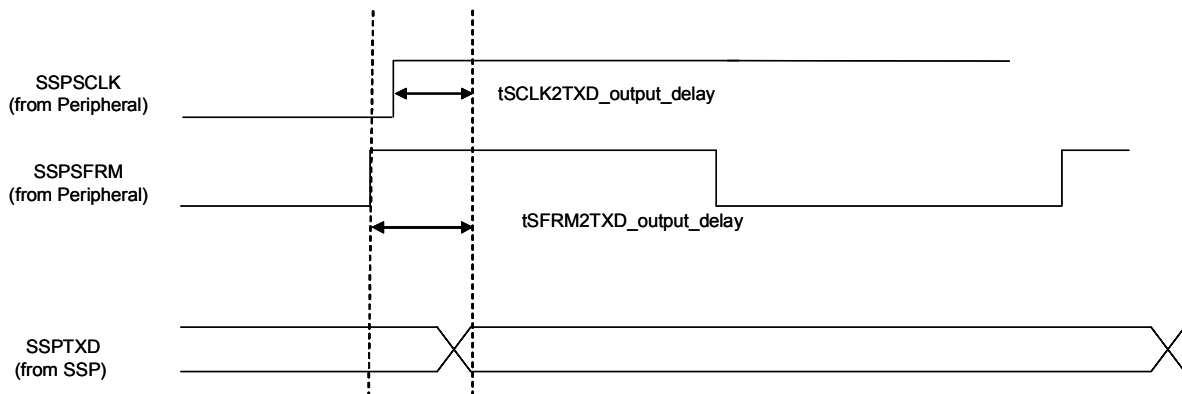



**Table 6-24. Timing Specification for SSP Slave Mode Transmitting Data to External Peripheral**

Parameter	Description	Min	Typ	Max	Units
tSFRM2TXD_output_delay	Frame to TX Data Out		10.58		ns
tSCLK2TXD_output_delay	Clock to Tx Data Out		10.52		ns

**Figure 6-31. Timing Diagram for SSP Slave Mode Receiving Data from External Peripheral**

PXA27 processor receiving data

PXA27x SSP (Slave Mode receiving data from external peripheral)

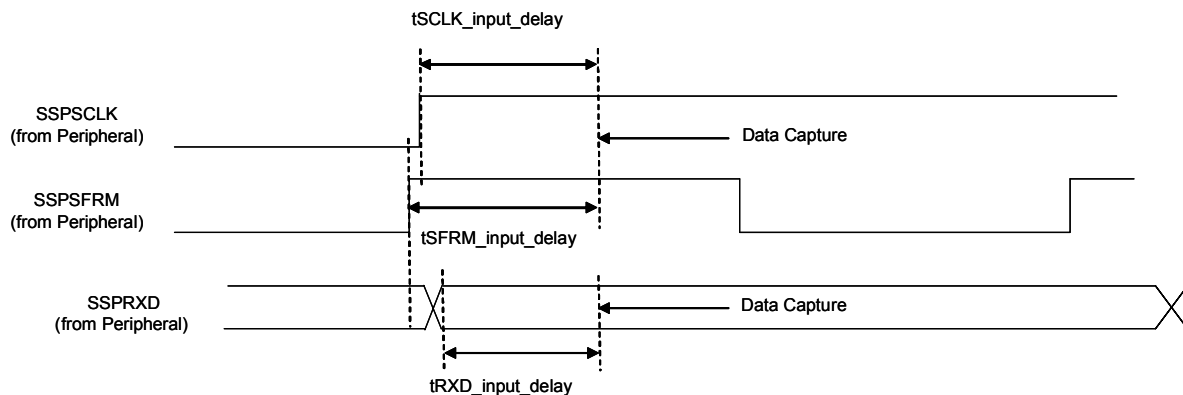
**Table 6-25. Timing Specification for SSP Slave Mode Receiving Data from External Peripheral**

Parameter	Description	Min	Typical	Max	Units
tSFRM_input_delay	Frame to Rx Data Capture		5.21		ns
tSCLK_input_delay	Clock to Rx Data Capture		5.04		ns
tRXD_input_delay	Rx Data Setup to Capture		4.81		ns

## 6.7 JTAG Boundary Scan Timing Specifications

Table 6-26 shows the AC specifications for the JTAG boundary-scan test-signals. Figure 6-32 shows the timing diagram.

**Table 6-26. Boundary Scan Timing Specifications (Sheet 1 of 2)**

Symbol	Parameter	Min	Max	Units	Notes
TBSF	TCK Frequency	0.0	33.33	MHz	—
TBSCH	TCK High Time	15.0	—	ns	Measured at 1.5 V
TBSCL	TCK Low Time	15.0	—	ns	Measured at 1.5 V
TBSCR	TCK Rise Time	—	5.0	ns	0.8 V to 2.0 V
TBSCF	TCK Fall Time	—	5.0	ns	2.0 V to 0.8 V

Table 6-26. Boundary Scan Timing Specifications (Sheet 2 of 2)

Symbol	Parameter	Min	Max	Units	Notes
TBSIS1	Input Setup to TCK TDI, TMS	4.0	—	ns	—
TBSIH1	Input Hold from TCK TDI, TMS	6.0	—	ns	—
TBSIS2	Input Setup to TCK nTRST	25.0	—	ns	—
TBSIH2	Input Hold from TCK nTRST	3.0	—	ns	—
TnTRST	Assertion time of nTRST	6	—	ms	—
TBSOV1	TDO Valid Delay	1.5	6.9	ns	Relative to falling edge of TCK
TOF1	TDO Float Delay	1.1	5.4	ns	Relative to falling edge of TCK

Figure 6-32. JTAG Boundary-Scan Timing

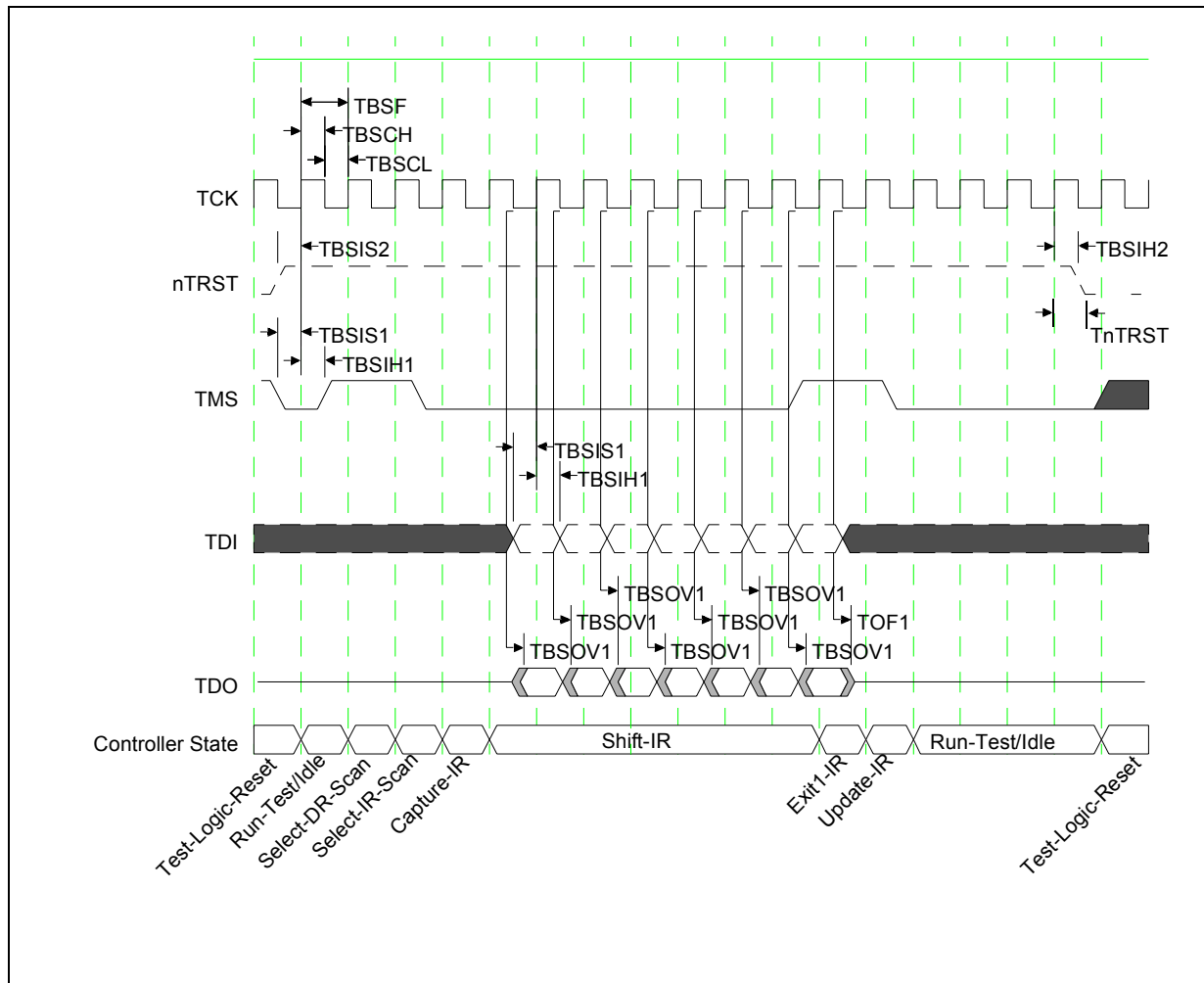

§§



# Intel® PXA27x Processor Family

## Programmer Enabling

**A**

The Intel PXA27x processor family is a high-performance, low-power microprocessor now available with additional memory chips. One of the chips available within the family is the Intel StrataFlash® wireless memory (L18).

### A.1 Introduction

This chapter describes how to prepare the Intel PXA27x processor for flash memory programming, and how to reduce programming time in a factory environment.

The Intel PXA27x processor can be enabled to program flash using one of two different methods. One method focuses on programming the Intel PXA27x processor prior to assembly; the other focuses on waiting until after the Intel PXA27x processor has been assembled before programming. Perhaps both methods might be suitable, depending on the design requirements. This chapter explains the trade-offs between different methods, thus helping reduce time in a factory environment and/or reducing cost of development.

The *direct-access programming* method requires minimum software development and takes less time to program the flash memory. Direct-access programming requires that all other memory devices along with the Intel PXA27x processor be placed into high-z (by issuing a JTAG high-z instruction) while programming the Intel StrataFlash® wireless memory. All the power domains must be brought up to their required voltages to prevent damage to the part. All other memories are placed into high-z by applying power and ensuring the de-assertion of their chip-select signals.

The second method for programming flash within the Intel PXA27x processor requires a greater amount of code development through the JTAG controller. It is a slower programming method but requires fewer pins. This method does not require any of the memory address, data, or control signals to be pinned out. Flash loader code is loaded into the Intel PXA27x processor mini-instruction cache. The code is then executed and uses the Intel PXA27x memory controller to program the flash and de-select the other memory devices that might be present within the SCSP. This method is referred to as *JTAG flash programming*. All the power domains on Intel PXA27x processors must be brought up to their required voltages to prevent damage to the part. All input signals not used must be driven to prevent excessive current usage. Refer to the *Intel® PXA27x Processor Design Guide* “Debug Interface” chapter for JTAG- specific command information.

[Table A-1](#) shows the comparison using either the *direct-access programming* method or the *JTAG flash programming* method.

**Table A-1. Direct Access versus JTAG Flash Programming<sup>1</sup>**

Methods	Maximum MB/s Flash Programming Time (32-bit)	Maximum MB/s Flash Programming Time (16-bit)	Total Signals Required to be Pinout of End User Product	Software Development Effort
Direct Access Programming	57.14	28.57 <sup>4</sup>	51 <sup>2</sup>	JTAG high-z Instruction
JTAG Flash Programming	4.125 <sup>5</sup>	4.125 <sup>5</sup>	5 <sup>3</sup>	JTAG Flash Programmer residing within the mini I-cache

1. Data rates are best case not accounting for any overhead (that is, running a checksum algorithm and downloading the flash loader into the PXA27x processor mini-instruction cache)
2. These signals (include address, data, control and JTAG) require a connector on the end user's product.
3. Depending on the system design, a connector on the end user's product requires nRESET, nTRST, TMS, TDI, and TCK. TDO is optional.
4. Calculated based on TCK (max) = 33MHz. MB/s = 33MHz / 8 bits
5. Calculated based on tWLWH = 50ns and tWHWL = 20ns. MB/s = 1/((tWLWH+tWHWL) / 2)

## A.2 Device Configuration

The Intel PXA27x processor uses a PXA27x processor die combined with either flash memory die or flash and SDRAM memory chips all packaged together. Currently available Intel PXA27x processor configurations are as follows:

- 32 MBytes of Intel StrataFlash® memory and 32 MBytes of low-power SDRAM
- 64 MBytes of Intel StrataFlash® memory
- 32 MBytes of Intel StrataFlash® memory

## A.3 Procedure to Prepare Intel® PXA27x Processor for Programming Flash

The following steps describe the procedure to prepare the Intel PXA27x processor using either the direct-access programming method or the JTAG-flash programming method. To prepare for direct-access programming, the internal memories other than flash are de-selected by de-asserting the dedicated chip-select signals and the Intel PXA27x processor must be placed into high-Z using high-Z JTAG command.

To prepare for JTAG flash programming, bring the Intel PXA27x processor out of reset. It is responsible for controlling all the memory signals and receiving the data to program the flash devices through the JTAG controller.

### A.3.1 Sequence Required for Direct-Access Programming

Follow the steps below to prepare the Intel PXA27x processor for direct-access programming. Use the power-on timing specifications with respect to applying power to the required domains as documented in [Section 6.2.1](#).

1. Drive all memory chip selects (other than flash) to their inactive state to guarantee the other memories are not contending with the flash signals (that is, XCS signal for SDRAM must be driven high).

2. Drive CLK\_REQ pin low, nBATT\_FAULT pin high, and nVDD\_FAULT pin high.
  3. Apply a hardware reset to the MCP by asserting nRESET and nTRST together.<sup>†</sup>
  4. Release reset by de-asserting nRESET and nTRST together.
  5. Wait for nRESET\_OUT to de-assert.
  6. Issue the High-Z JTAG command to place PXA27x processor signals into high-z state.
  7. Begin programming the in-chip flash devices.<sup>††</sup>
- <sup>†</sup> nRESET\_OUT from the PXA27x processor die must be externally connected to the nRST input of the Flash die using a level shifter.

**Figure A-1. Diagram Showing Steps for Putting Intel® PXA27x Processor into High-Z**

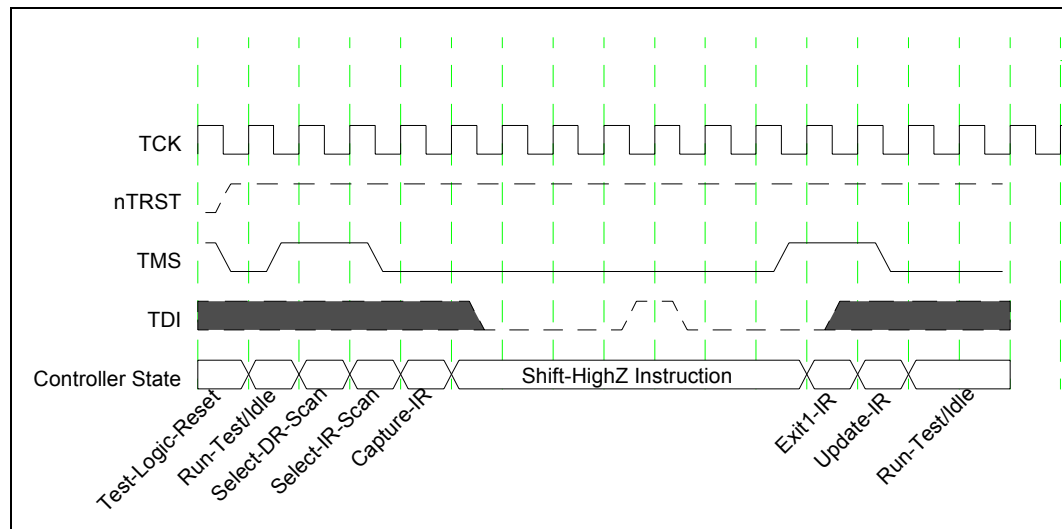

### A.3.2 Sequence Required for JTAG Flash Programming

Follow the steps below to prepare the Intel PXA27x processor for JTAG flash programming. Use the power-on timing specifications with respect to applying power to the required domains as documented in [Section 6.2.1](#).

1. Drive CLK\_REQ pin low, nBATT\_FAULT pin high, and nVDD\_FAULT pin high.
2. Apply a hardware reset to the SCSP by asserting nRESET and nTRST together.<sup>†</sup>
3. Release JTAG reset by de-asserting nTRST.
4. Follow steps documented in Download Code in the instruction cache seen in the *Intel® PXA27x Processor Family Developer's Manual*.
5. Download the flash loader utility into the mini-instruction cache, start execution of the flash loader utility.
6. 10 $\mu$ s must elapse after nTRST is de-asserted before proceeding with any JTAG operation.
7. De-assert nRESET.
8. Wait for nRESET\_OUT to de-assert.
9. Begin sending raw data through the JTAG port to program the in-chip flash devices.

† nRESET\_OUT from the PXA27x processor die must be externally connected to the nRST input of the Flash die using a level shifter.

## A.4 Intel PXA27x Processor Connections for Flash Programming

Table A-2 describes the connections for existing Intel PXA27x processor configurations. Table A-2 is specific for the Intel PXA27x processor. Table A-2 shows the minimum number of balls that must be connected to program the Intel StrataFlash® wireless memory internal to the package for each of the two programming methods as described in Section A.1.

For direct-access flash programming, the balls needed are determined based on the power signals and control signals required for placing the Intel PXA27x processor into a high-z state. For the JTAG-flash programming method, the signals needed are only those that power up the Intel PXA27x processor such that the JTAG controller can program flash through the Intel PXA27x processor memory controller.

Table A-2 shows the connections required for programming the Intel StrataFlash® wireless memory within the Intel PXA27x processor. The first two columns in Table A-2 show which signals must be accessed depending on the method used to program the Intel StrataFlash® wireless memory. Use the list below to decode the letter representing the die within the Intel PXA27x processor.

Abbreviations Used in Table A-2	
f	ball required to program flash
b	ball required by the PXA27x processor
s	ball required to deselect SDRAM
v	voltage supply connection required
rfu	reserved for future use
o	optional (may not be required depending on system design)

Signals required to be tied high must be tied to VCC\_BATT in deep sleep and tied to VCC\_IO at all other times unless stated differently.



**Table A-2. Required Balls for Programming Intel StrataFlash® Wireless Memory (Sheet 1 of 8)**

Required Balls (JTAG Flash Programming)	Required Balls (Direct Access Programming)	SCSP Ball Position	SCSP Ball Name	PXA27x Processor Function	1.8V 256Mb-L18 Function (16-bit total data bus width) Intel® PXA271 Configuration	1.8V 256Mb SDRAM Function (16-bit total data bus width) Intel® PXA271 Configuration	1.8V 256Mb/128Mb-L18 Function (32-bit total data bus width) Intel® PXA272 and 273 Configuration	Signal Instruction
Memory Address Signals								
	f	V2	MA<25>	MA<25>	—	—	A23	Memory Address Signals
	f	W2	MA<24>	MA<24>	A23	BA1	A22	
	f	W4	MA<23>	MA<23>	A22	BA0	A21	
	f	Y4	MA<22>	MA<22>	A21	—	A20	
	f	W5	MA<21>	MA<21>	A20	—	A19	
	f	T4	MA<20>	MA<20>	A19	—	A18	
	f	R4	MA<19>	MA<19>	A18	—	A17	
	f	P2	MA<18>	MA<18>	A17	—	A16	
	f	W6	MA<17>	MA<17>	A16	—	A15	
	f	T5	MA<16>	MA<16>	A15	—	A14	
	f	R5	MA<15>	MA<15>	A14	—	A13	
	f	V6	MA<14>	MA<14>	A13	—	A12	
	f	U6	MA<13>	MA<13>	A12	A12	A11	
	f	T6	MA<12>	MA<12>	A11	A11	A10	
	f	W7	MA<11>	MA<11>	A10	A10	A9	
	f	P4	MA<10>	MA<10>	A9	A9	A8	
	f	P5	MA<9>	MA<9>	A8	A8	A7	
	f	T7	MA<8>	MA<8>	A7	A7	A6	
	f	R6	MA<7>	MA<7>	A6	A6	A5	
	f	N5	MA<6>	MA<6>	A5	A5	A4	
	f	W8	MA<5>	MA<5>	A4	A4	A3	
	f	R7	MA<4>	MA<4>	A3	A3	A2	
	f	P6	MA<3>	MA<3>	A2	A2	A1	
	f	T8	MA<2>	MA<2>	A1	A1	A0	
	f	Y3	MA<1>	MA<1>	A0	A0	—	
		W3	MA<0>	MA<0>	—	—	—	



**Table A-2. Required Balls for Programming Intel StrataFlash® Wireless Memory (Sheet 2 of 8)**

Required Balls (JTAG Flash Programming)	Required Balls (Direct Access Programming)	SCSP Ball Position	SCSP Ball Name	PXA27x Processor Function	1.8V 256Mb-L18 Function (16-bit total data bus width) Intel® PXA271 Configuration	1.8V 256Mb SDRAM Function (16-bit total data bus width) Intel® PXA271 Configuration	1.8V 256Mb/128Mb-L18 Function (32-bit total data bus width) Intel® PXA272 and 273 Configuration	Signal Instruction
Memory Data Signals								





**Table A-2. Required Balls for Programming Intel StrataFlash® Wireless Memory (Sheet 3 of 8)**

Required Balls (JTAG Flash Programming)	Required Balls (Direct Access Programming)	SCSP Ball Position	SCSP Ball Name	PXA27x Processor Function	1.8V 256Mb-L18 Function (16-bit total data bus width) Intel® PXA271 Configuration	1.8V 256Mb SDRAM Function (16-bit total data bus width) Intel® PXA271 Configuration	1.8V 256Mb/128Mb-L18 Function (32-bit total data bus width) Intel® PXA272 and 273 Configuration	Signal Instruction
	f	M5	MD<31>	MD<31>	—	—	D31	Memory Data Signals
	f	L5	MD<30>	MD<30>	—	—	D30	
	f	L6	MD<29>	MD<29>	—	—	D29	
	f	T9	MD<28>	MD<28>	—	—	D28	
	f	T10	MD<27>	MD<27>	—	—	D27	
	f	R11	MD<26>	MD<26>	—	—	D26	
	f	R12	MD<25>	MD<25>	—	—	D25	
	f	U13	MD<24>	MD<24>	—	—	D24	
	f	P15	MD<23>	MD<23>	—	—	D23	
	f	R15	MD<22>	MD<22>	—	—	D22	
	f	N15	MD<21>	MD<21>	—	—	D21	
	f	W14	MD<20>	MD<20>	—	—	D20	
	f	U15	MD<19>	MD<19>	—	—	D19	
	f	T16	MD<18>	MD<18>	—	—	D18	
	f	N16	MD<17>	MD<17>	—	—	D17	
	f	N17	MD<16>	MD<16>	—	—	D16	
	f	N6	MD<15>	MD<15>	D15	D0	D15	
	f	M6	MD<14>	MD<14>	D14	D1	D14	
	f	R8	MD<13>	MD<13>	D13	D3	D13	
	f	R9	MD<12>	MD<12>	D12	D2	D12	
	f	R10	MD<11>	MD<11>	D11	D5	D11	
	f	T11	MD<10>	MD<10>	D10	D4	D10	
	f	T12	MD<9>	MD<9>	D9	D7	D9	
	f	R14	MD<8>	MD<8>	D8	D6	D8	
	f	V13	MD<7>	MD<7>	D7	D9	D7	
	f	T14	MD<6>	MD<6>	D6	D8	D6	
	f	M15	MD<5>	MD<5>	D5	D11	D5	
	f	M16	MD<4>	MD<4>	D4	D10	D4	
	f	V15	MD<3>	MD<3>	D3	D13	D3	
	f	P16	MD<2>	MD<2>	D2	D12	D2	

**Table A-2. Required Balls for Programming Intel StrataFlash® Wireless Memory (Sheet 4 of 8)**

Required Balls (JTAG Flash Programming)	Required Balls (Direct Access Programming)	SCSP Ball Position	SCSP Ball Name	PXA27x Processor Function	1.8V 256Mb-L18 Function (16-bit total data bus width) Intel® PXA271 Configuration	1.8V 256Mb SDRAM Function (16-bit total data bus width) Intel® PXA271 Configuration	1.8V 256Mb/128Mb-L18 Function (32-bit total data bus width) Intel® PXA272 and 273 Configuration	Signal Instruction
Memory Control Signals								
	f	V19	SDCLK<3>	SDCLK<3>	F-CLK	—	F-CLK	Flash clock signals: Max 54 MHz external. Used for Synchronous Reads - If only asynchronous reads are to be performed, CLK must be tied to VCC_MEM, WAIT signal can be floated and ADV# must be tied to ground.
	f	W1	NCS<0>	nCS<0>	F1-CE#	—	F1-CE#	Flash chip select
	f	W19	NOE	nOE	OE#	—	OE#	Flash Output Enable
	f	Y8	NF_RST	—	F-RST#	—	F-RST#	Connect to the nRESET_OUT (B19) output signal of the PXA27x processor die (level-shifter required)
	f	W10	F_VPP	—	F-VPP	—	F-VPP	VPP must be above VPPLK, and within the specified VPPLmin/max values (nominally 1.8V). Refer to the flash datasheet for additional information showing example VPP supply connections.
	f	W15	NF_WP<0>	—	F-WP1#	—	F-WP1#	Tie High to VCC_MEM
	rfu	Y14	NF_WP<1>	—	—	—	—	Reserved for a stacked data flash memory write protection pin (not yet available in any current MCP configurations) Tie High to VCC_MEM
	f	W20	NWE	nWE	WE#	WE#	WE#	Flash Write Enable
		P19	SDCLK<1>	SDCLK<1>	—	R-CLK	—	SDRAM clock signals (no connect)
	s	V18	NSDCS<0>	NSDCS<0>	—	D1-CS#	—	Tie High to VCC_MEM
		W18	DQM<0>	DQM<0>	—	D-DM1	—	SDRAM Byte Mask (no connect)
		P17	DQM<1>	DQM<1>	—	D-DM0	—	
		T18	SDCKE	SDCKE	—	D-CKE	—	SDRAM Clock Enable (no connect)
	f	U20	NSDCA S	nSDCAS	ADV#	D-CAS	ADV#	Flash Address Valid signal



**Table A-2. Required Balls for Programming Intel StrataFlash® Wireless Memory (Sheet 5 of 8)**

Required Balls (JTAG Flash Programming)	Required Balls (Direct Access Programming)	SCSP Ball Position	SCSP Ball Name	PXA27x Processor Function	1.8V 256Mb-L18 Function (16-bit total data bus width) Intel® PXA271 Configuration	1.8V 256Mb SDRAM Function (16-bit total data bus width) Intel® PXA271 Configuration	1.8V 256Mb/128Mb-L18 Function (32-bit total data bus width) Intel® PXA272 and 273 Configuration	Signal Instruction
	o	M4	RDNWR	RDnWR	—	—	—	Used to drive the direction signal of external buffers
b	b	B18	BOOT_SEL	BOOT_SEL	—	—	—	Boot select signal that configures the memory controller for the bus width of the boot memory: Tie low for 32-bit boot flash Tie high to VCC_MEM for 16-bit boot flash
PXA27x processor TestCLK								
b	b	A13	TESTCLK	TESTCLK	—	—	—	Reserved for manufacturing test. Must be grounded for normal operation.
PXA27x processor JTAG Interface								
b	b	B14	TDI	TDI	—	—	—	JTAG Debug signals, refer to the Debug Interface chapter of the <i>PXA27x Processor Family Design Guide</i> for additional information
b	b	E14	TCK	TCK	—	—	—	
b	b	D14	TDO	TDO	—	—	—	
b	b	C13	TMS	TMS	—	—	—	
b	b	C14	nTRST	nTRST	—	—	—	
PXA27x processor Clock Signals								
b	b	E19	PXTAL_IN	PXTAL_IN	—	—	—	Must connect to a 13 MHz crystal or oscillator. Refer to <a href="#">Section 5.5.2</a> , "13.000-MHz Oscillator Specifications" for detail information.
b	b	E20	PXTAL_OUT	PXTAL_OUT	—	—	—	
b	b	B17	TX TAL_IN	TX TAL_IN	—	—	—	If register OSCC[OON] and OSCC[GRI] are both clear, TX TAL_IN can be left unconnected or grounded. Refer to the Clocks and Power Chapter of the <i>Intel® PXA27x Processor Family Developer's Manual</i> for additional information.
b	b	A17	TX TAL_OUT	TX TAL_OUT	—	—	—	If register OSCC[OON] and OSCC[GRI] are both clear, TX TAL_OUT can remain unconnected
b	b	E15	CLK_REQ	CLK_REQ	—	—	—	Tie low
PXA27x processor Power Control Signals								

**Table A-2. Required Balls for Programming Intel StrataFlash® Wireless Memory (Sheet 6 of 8)**

Required Balls (JTAG Flash Programming)	Required Balls (Direct Access Programming)	SCSP Ball Position	SCSP Ball Name	PXA27x Processor Function	1.8V 256Mb-L18 Function (16-bit total data bus width) Intel® PXA271 Configuration	1.8V 256Mb SDRAM Function (16-bit total data bus width) Intel® PXA271 Configuration	1.8V 256Mb/128Mb-L18 Function (32-bit total data bus width) Intel® PXA272 and 273 Configuration	Signal Instruction
b	b	B16	PWR_EN	PWR_EN	—	—	—	Use the power-on timing specifications for power-up sequencing documented in <a href="#">Section 6.2.1</a>
b	b	D17	SYS_EN	SYS_EN	—	—	—	
b	b	A16	nRESET	nRESET	—	—	—	
b	b	B19	nRESET_OUT	nRESET_OUT	—	—	—	Connect externally to the input nRST signal (Y8) of the flash die.
b	b	C17	nVDD_F AULT	nVDD_F AULT	—	—	—	Tie high
b	b	C18	nBATT_FAULT	nBATT_FAULT	—	—	—	Tie high
b	b	D20	PWR_OUT	PWR_OUT	—	—	—	0.1 µF cap to ground
b	b	C19	GPIO<5>	PWR_C AP<0>	—	—	—	0.1 µF cap between the pins
b	b	D18	GPIO<6>	PWR_C AP<1>	—	—	—	
b	b	E18	GPIO<7>	PWR_C AP<2>	—	—	—	0.1 µF cap between the pins
b	b	E16	GPIO<8>	PWR_C AP<3>	—	—	—	
b	b	A15	GPIO<0>	GPIO<0>	—	—	—	The GPIO<0> pin has an internal resistive pull-down and the GPIO<1> has an internal resistive pull-up that are enabled during power-on, hardware, watchdog, and GPIO resets. The pull-up/down is disabled when PSSR[RDH] bit field is clear. See the <i>Intel® PXA27x Family Processor Developer's Manual</i> Clocks and Power chapter for additional information.
b	b	D16	GPIO<1>	GPIO<1>	—	—	—	
Power Connections								
v	v	E17	VCC_BATT	VCC_BATT	—	—	—	Apply 3.0V +/- 25%



**Table A-2. Required Balls for Programming Intel StrataFlash® Wireless Memory (Sheet 7 of 8)**

Required Balls (JTAG Flash Programming)	Required Balls (Direct Access Programming)	SCSP Ball Position	SCSP Ball Name	PXA27x Processor Function	1.8V 256Mb-L18 Function (16-bit total data bus width) Intel® PXA271 Configuration	1.8V 256Mb SDRAM Function (16-bit total data bus width) Intel® PXA271 Configuration	1.8V 256Mb/128Mb-L18 Function (32-bit total data bus width) Intel® PXA272 and 273 Configuration	Signal Instruction
v	v	A12,B7, B9,B11, E1,J19, K3,L19, R2,R20, T13, T15,U1	VCC_C ORE	VCC_C ORE	—	—	—	Apply 1.3V +/- 10%
v	v	F18	VCC_PL L	VCC_PL L	—	—	—	
v	v	M3,N3, R3,U3	VCC_SR AM	VCC_SR AM	—	—	—	Apply 1.1V +/- 10%
v	v	C6	VCC_US IM	VCC_US IM	—	—	—	Apply 3.0V +/- 10%
v	v	L20	VCC_BB	VCC_BB	—	—	—	
v	v	A11,B8	VCC_LC D	VCC_LC D	—	—	—	
v	v	A1,A2, D1	VCC_US B	VCC_US B	—	—	—	
v	v	H20,J1, L1	VCC_IO	VCC_IO	—	—	—	
v	v	N1,N20, P20, R19, R1,V7, V9, V11,V14, V17,Y20 , T2,V5, V8,V10, V12,V16 , Y7,Y6, Y10,Y11, Y12, Y13, Y16	VCC_M EM	VCC_M EM	F-VCC, VCCQ	F-VCC, VCCQ	F-VCC, VCCQ	Apply 1.8V -5/+10%

**Table A-2. Required Balls for Programming Intel StrataFlash® Wireless Memory (Sheet 8 of 8)**

Required Balls (JTAG Flash Programming)	Required Balls (Direct Access Programming)	SCSP Ball Position	SCSP Ball Name	PXA27x Processor Function	1.8V 256Mb-L18 Function (16-bit total data bus width) Intel® PXA271 Configuration	1.8V 256Mb SDRAM Function (16-bit total data bus width) Intel® PXA271 Configuration	1.8V 256Mb/128Mb-L18 Function (32-bit total data bus width) Intel® PXA272 and 273 Configuration	Signal Instruction
v	v	K16	VSS_BB	VSS_BB	—	—	—	Connect to ground
v	v	C1,E7, E10,F9, F11,F13, H15,J5, K6,N4, R13, R16,U2, U4,U18, V3,Y1	VSS_CO RE	VSS_CO RE	—	—	—	
v	v	F19	VSS_PL L	VSS_PL L	—	—	—	
v	v	A18,A19 , A20, B20,C15 , C20, D19, N2, N18, P18, T1, U5, U7, U8, U9, U10, U11, U12, U14, U16, U19, Y2, W11, Y5, Y9, Y17	VSS_ME M, VSS	VSS_ME M, VSS	VSSQ, VSS	VSSQ, VSS	VSSQ, VSS	
v	v	B13,D6, D9, E12,E4, F20, G15, J2,L2	VSS_IO	VSS_IO	—	—	—	
v	v	W11,Y5, Y9,Y17	VSS	—	—	—	—	
GPIO Signals								
b		Either configure all GPIO signals as outputs or drive all GPIO input signals. <b>NOTE:</b> Output pads must not be driven by the system; and, for minimal system power consumption, they must not be allowed to drive other logic in the system that uses different supply levels.						



## **A.5 Intel PXA27x Processor Mechanical Drawing**

Refer to Chapter 3 for the Intel PXA27x processor mechanical drawing.

## **A.6 Intel PXA27x Processor Ballout**

Refer to Chapter 4 for the Intel PXA27x processor ballout.

§§







## Glossary

---

**3G:** An industry term used to describe the next, still-to-come generation of wireless applications. It represents a move from circuit-switched communications (where a device user has to dial in to a network) to broadband, high-speed, packet-based wireless networks (which are always on). The first generation of wireless communications relied on analog technology, followed by digital wireless communications. The third generation expands the digital capabilities by including high-speed connections and increased reliability.

**802.11:** Wireless specifications developed by the IEEE, outlining the means to manage packet traffic over a network and ensure that packets do not collide, which could result in the loss of data, when travelling from device to device.

**8PSK:** 8 phase shift key modulation scheme. Used in the EDGE standard.

**AC '97:** AC-link standard serial interface for modem and audio

**ACK:** Handshake packet indicating a positive acknowledgment.

**Active device:** A device that is powered and is not in the suspended state.

**Air interface:** the RF interface between a mobile cellular handset and the base station

**AMPS:** Advanced Mobile Phone Service. A term used for analog technologies, the first generation of wireless technologies.

**Analog:** Radio signals that are converted into a format that allows them to carry data. Cellular phones and other wireless devices use analog in geographic areas with insufficient digital networks.

**ARM\* V5te:** An ARM\* architecture designation indicating the processor conforms to ARM\* architecture version 5, including “Thumb” mode and the “El Segundo” DSP extensions.

**Asynchronous Data:** Data transferred at irregular intervals with relaxed latency requirements.

**Asynchronous RA:** The incoming data rate,  $F_{s_i}$ , and the outgoing data rate,  $F_{s_o}$ , of the RA process are independent (i.e., there is no shared master clock). See also *rate adaptation*.

**Asynchronous SRC:** The incoming sample rate,  $F_{S_i}$ , and outgoing sample rate,  $F_{S_o}$ , of the SRC process are independent (i.e., there is no shared master clock). See also sample *rate conversion*.

**Audio device:** A device that sources or sinks sampled analog data.

**AWG#:** The measurement of a wire’s cross-section, as defined by the American Wire Gauge standard.

**Babble:** Unexpected bus activity that persists beyond a specified point in a (micro)frame.

**Backlight Inverter:** A device to drive cold cathode fluorescent lamps used to illuminate LCD panels.

**Bandwidth:** The amount of data transmitted per unit of time, typically bits per second (b/s) or bytes per second (B/s). The size of a network “pipe” or channel for communications in wired networks. In wireless, it refers to the range of available frequencies that carry a signal.

**Base Station:** The telephone company’s interface to the Mobile Station



**BGA:** Ball Grid Array

**BFSK:** binary frequency shift keying. A coding scheme for digital data.

**Bit:** A unit of information used by digital computers. Represents the smallest piece of addressable memory within a computer. A bit expresses the choice between two possibilities and is typically represented by a logical one (1) or zero (0).

**Bit Stuffing:** Insertion of a “0” bit into a data stream to cause an electrical transition on the data wires, allowing a PLL to remain locked.

**Blackberry:** A two-way wireless device (pager) made by Research In Motion (RIM) that allows users to check e-mail and voice mail translated into text, as well as page other users of a wireless network service. It has a miniature “qwerty” keyboard that can be used by your thumbs, and uses SMS protocol. A Blackberry user must subscribe to the proprietary wireless service that allows for data transmission.

**Bluetooth:** A short-range wireless specification that allows for radio connections between devices within a 30-foot range of each other. The name comes from 10th-century Danish King Harald Blatand (Bluetooth), who unified Denmark and Norway.

**BPSK:** binary phase shift keying. A means of encoding digital data into a signal using phase-modulated communications.

**b/s:** Transmission rate expressed in bits per second.

**B/s:** Transmission rate expressed in bytes per second.

**BTB:** Branch Target Buffer

**BTS:** Base Transmitter Station

**Buffer:** Storage used to compensate for a difference in data rates or time of occurrence of events, when transmitting data from one device to another.

**Bulk Transfer:** One of the four USB transfer types. Bulk transfers are non-periodic, large bursty communication typically used for a transfer that can use any available bandwidth and can also be delayed until bandwidth is available. See also *transfer type*.

**Bus Enumeration:** Detecting and identifying USB devices.

**Byte:** A data element that is eight bits in size.

**Capabilities:** Those attributes of a USB device that are administrated by the host.

**CAS:** Cycle Accurate Simulator

**CAS-B4-RAS:** See CBR.

**CBR:** CAS Before RAS. Column Address Strobe Before Row Address Strobe. A fast refresh technique in which the DRAM keeps track of the next row it needs to refresh, thus simplifying what a system would have to do to refresh the part.

**CDMA:** Code Division Multiple Access U.S. wireless carriers Sprint PCD and Verizon use CDMA to allocate bandwidth for users of digital wireless devices. CDMA distinguishes between multiple transmissions carried simultaneously on a single wireless signal. It carries the transmissions on that signal, freeing network room for the



wireless carrier and providing interference-free calls for the user. Several versions of the standard are still under development. CDMA should increase network capacity for wireless carriers and improve the quality of wireless messaging. CDMA is an alternative to GSM.

**CDPD:** Cellular Digital Packet Data Telecommunications companies can use DCPD to transfer data on unused cellular networks to other users. If one section, or “cell” of the network is overtaxed, DCPD automatically allows for the reallocation of services.

**Cellular:** Technology that senses analog or digital transmissions from transmitters that have areas of coverage called cells. As a user of a cellular phone moves between transmitters from one cell to another, the users’ call travels from transmitter to transmitter uninterrupted.

**Circuit Switched:** Used by wireless carriers, this method lets a user connect to a network or the Internet by dialing in, such as with a traditional phone line. Circuit switched connections are typically slower and less reliable than packet-switched networks, but are currently the primary method of network access for wireless users in the U.S.

**CF:** Compact Flash memory and I/O card interface

**Characteristics:** Those qualities of a USB device that are unchangeable; for example, the device class is a device characteristic.

**Client:** Software resident on the host that interacts with the USB System Software to arrange data transfer between a function and the host. The client is often the data provider and consumer for transferred data.

**CML:** Current mode logic

**Configuring Software:** Software resident on the host software that is responsible for configuring a USB device. This may be a system configuration or software specific to the device.

**Control Endpoint:** A pair of device endpoints with the same endpoint number that are used by a control pipe. Control endpoints transfer data in both directions and, therefore, use both endpoint directions of a device address and endpoint number combination. Thus, each control endpoint consumes two endpoint addresses.

**Control Pipe:** Same as a message pipe.

**Control Transfer:** One of the four USB transfer types. Control transfers support configuration/command/status type communications between client and function. See also *transfer type*.

**CRC:** See Cyclic Redundancy Check.

**CSP:** Chip Scale Package.

**CTE:** Coefficient of thermal expansion

**CTI:** Computer Telephony Integration.

**Cyclic Redundancy Check (CRC):** A check performed on data to see if an error has occurred in transmitting, reading, or writing the data. The result of a CRC is typically stored or transmitted with the checked data. The stored or transmitted result is compared to a CRC calculated for the data to determine if an error has occurred.

**D-cache:** Data cache

**DECT:** the Digital European Cordless Telecommunications standard

**Default Address:** An address defined by the USB Specification and used by a USB device when it is first powered or reset. The default address is 00H.



**Default Pipe:** The message pipe created by the USB System Software to pass control and status information between the host and a USB device's endpoint zero.

**Device:** A logical or physical entity that performs a function. The actual entity described depends on the context of the reference. At the lowest level, "device" may refer to a single hardware component, as in a memory device. At a higher level, it may refer to a collection of hardware components that perform a particular function, such as a USB interface device. At an even higher level, device may refer to the function performed by an entity attached to the USB; for example, a data/FAX modem device. Devices may be physical, electrical, addressable, and logical. When used as a non-specific reference, a USB device is either a hub or a function.

**Device Address:** A seven-bit value representing the address of a device on the USB. The device address is the default address (00H) when the USB device is first powered or the device is reset. Devices are assigned a unique device address by the USB System Software.

**Device Endpoint:** A uniquely addressable portion of a USB device that is the source or sink of information in a communication flow between the host and device. See also *endpoint address*.

**Device Resources:** Resources provided by USB devices, such as buffer space and endpoints. See also *Host Resources and Universal Serial Bus Resources*.

**Device Software:** Software that is responsible for using a USB device. This software may or may not also be responsible for configuring the device for use.

**DMA:** Direct Memory Access

**Downstream:** The direction of data flow from the host or away from the host. A downstream port is the port on a hub electrically farthest from the host that generates downstream data traffic from the hub. Downstream ports receive upstream data traffic.

**DQPSK:** Differential Quadrature Phase Shift Keying a modulation technique used in TDMA.

**Driver:** When referring to hardware, an I/O pad that drives an external load. When referring to software, a program responsible for interfacing to a hardware device, that is, a device driver.

**DSP:** Digital Signal Processing

**DSTN** Passive LCD Panel.

**Dual band mobile phone:** A phone that supports both analog and digital technologies by picking up analog signals when digital signals fade. Most mobile phones are not dual-band.

**DWORD:** Double word. A data element that is two words (i.e., four bytes or 32 bits) in size.

**Dynamic Insertion and Removal:** The ability to attach and remove devices while the host is in operation.

**E2PROM:** See Electrically Erasable Programmable Read Only Memory.

**EAV:** End of active video

**EDGE:** Enhanced Data GSM Environment. A faster version of the GSM standard. It is faster because it can carry messages using broadband networks that employ more bandwidth than standard GSM networks.

**EEPROM:** See Electrically Erasable Programmable Read Only Memory.

**Electrically Erasable Programmable Read Only Memory (EEPROM):** Non-volatile re-writable memory storage technology.



**End User:** The user of a host.

**Endpoint:** See device endpoint.

**Endpoint Address:** The combination of an endpoint number and an endpoint direction on a USB device. Each endpoint address supports data transfer in one direction.

**Endpoint Direction:** The direction of data transfer on the USB. The direction can be either IN or OUT. IN refers to transfers to the host; OUT refers to transfers from the host.

**Endpoint Number:** A four-bit value between 0H and FH, inclusive, associated with an endpoint on a USB device.

**Envelope detector:** An electronic circuit inside a USB device that monitors the USB data lines and detects certain voltage related signal characteristics.

**EOF:** End-of-(micro)Frame.

**EOP:** End-of-Packet.

**EOTD:** Enhanced Observed Time Difference

**ETM:** Embedded Trace Macrocell, the ARM\* real-time trace capability

**External Port:** See port.

**Eye pattern:** A representation of USB signaling that provides minimum and maximum voltage levels as well as signal jitter.

**FAR:** Fault Address Register, part of the ARM\* architecture.

**False EOP:** A spurious, usually noise-induced event that is interpreted by a packet receiver as an EOP.

**FDD:** The Mobile Station transmits on one frequency; the Base Station transmits on another frequency

**FDMA:** Frequency Division Multiple Access. An analog standard that lets multiple users access a group of radio frequency bands and eliminates interference of message traffic.

**FDMA:** Frequency Division Multiple Access. An analog standard that lets multiple users access a group of radio frequency bands and eliminates interference of message traffic.

**FHSS:** See Frequency Hopping Spread Spectrum.

**FIQ:** Fast Interrupt Request. See Interrupt Request.

**Frame:** A 1 millisecond time base established on full-/low-speed buses.

**Frame Pattern:** A sequence of frames that exhibit a repeating pattern in the number of samples transmitted per frame. For a 44.1 kHz audio transfer, the frame pattern could be nine frames containing 44 samples followed by one frame containing 45 samples.

**Frequency Hopping Spread Spectrum:** A method by which a carrier spreads out packets of information (voice or data) over different frequencies. For example, a phone call is carried on several different frequencies so that when one frequency is lost another picks up the call without breaking the connection.

**F<sub>s</sub>:** See sample rate.

**FSR:** Fault Status Register, part of the ARM\* architecture.



**Full-duplex:** Computer data transmission occurring in both directions simultaneously.

**Full-speed:** USB operation at 12 Mb/s. See also *low-speed and high-speed*.

**Function:** A USB device that provides a capability to the host, such as an ISDN connection, a digital microphone, or speakers.

**GMSK:** Gaussian Minimum Shift Keying. A modulation scheme used in GSM.

**GPRS:** General Packet Radio Service A technology that sends packets of data across a wireless network at speeds up to 114 Kbps. Unlike circuit-switched networks, wireless users do not have to dial in to networks to download information; GPRS wireless devices are “always on” in that they can send and receive data without dial-ins. GPRS works with GSM.

**GPS:** Global Positioning Systems

**GSM:** Global System for Mobile Communications. A standard for how data is coded and transferred through the wireless spectrum. The European wireless standard, also used in parts of Asia, GSM is an alternative to CDMA. GSM digitizes and compresses data and sends it across a channel with two other streams of user data. GSM is based on TDMA technology.

**Hamming Distance:** The distance (number of bits) between encoded values that can change without causing a decode into the wrong value.

**Handshake Packet:** A packet that acknowledges or rejects a specific condition. For examples, see ACK and NAK.

**HDML:** Handheld Device Markup Language. HDML uses hypertext transfer protocol (HTTP) to display text versions of web pages on wireless devices. Unlike WML, HDML is not based on XML. HDML does not allow scripts, while WML uses a variant of JavaScript. Web site developers using HDML must re-code their web pages in HDML to be viewed on the smaller screen sizes of handheld devices.

**HARP:** Windows CE standard development platform spec (Hardware Adaptation Reference Platform)

**High-bandwidth endpoint:** A high-speed device endpoint that transfers more than 1024 bytes and less than 3073 bytes per microframe.

**High-speed:** USB operation at 480 Mb/s. See also *low-speed and full-speed*.

**Host:** The host computer system where the USB Host controller is installed. This includes the host hardware platform (CPU, bus, and so forth.) and the operating system in use.

**Host Controller:** The host’s USB interface.

**Host Controller Driver (HCD):** The USB software layer that abstracts the Host controller hardware. The Host controller driver provides an SPI for interaction with a Host controller. The Host controller driver hides the specifics of the Host controller hardware implementation.

**Host Resources:** Resources provided by the host, such as buffer space and interrupts. See also *Device Resources and Universal Serial Bus Resources*.

**HSTL:** High-speed transceiver logic

**Hub:** A USB device that provides additional connections to the USB.

**Hub Tier:** One plus the number of USB links in a communication path between the host and a function.



**IMMU:** Instruction Memory Management Unit, part of the Intel XScale® core.

**I-Mode:** A Japanese wireless service for transferring packet-based data to handheld devices created by NTT DoCoMo. I-Mode is based on a compact version of HTML and does not currently use WAP.

**I-cache:** Instruction cache

**IBIS:** I/O Buffer Information Specification is a behavioral description of the I/O buffers and package characteristics of a semiconductor device. IBIS models use a standard format to make it easier to import data into circuit simulation software packages.

**iDEN:** Integrated Digital Enhanced Network. A technology that allows users to access phone calls, two-way radio transmissions, paging and data transmissions from one wireless device. iDEN was developed by Motorola and based on TDMA.

**Interrupt Request (IRQ):** A hardware signal that allows a device to request attention from a host. The host typically invokes an interrupt service routine to handle the condition that caused the request.

**Interrupt Transfer:** One of the four USB transfer types. Interrupt transfer characteristics are small data, non-periodic, low-frequency, and bounded-latency. Interrupt transfers are typically used to handle service needs. See also *transfer type*.

**I/O Request Packet:** An identifiable request by a software client to move data between itself (on the host) and an endpoint of a device in an appropriate direction.

**IrDA:** Infrared Development Association

**IRP:** See I/O Request Packet.

**IRQ:** See Interrupt Request.

**ISI:** Inter-signal interference. Data ghosting caused when multi-path delay causes previous symbols to interfere with the one currently being processed.

**ISM:** Industrial, Scientific, and Medical band. Part of the wireless spectrum that is less regulated, such as 802.11.

**Isochronous Data:** A stream of data whose timing is implied by its delivery rate.

**Isochronous Device:** An entity with isochronous endpoints, as defined in the USB Specification, that sources or sinks sampled analog streams or synchronous data streams.

**Isochronous Sink Endpoint:** An endpoint that is capable of consuming an isochronous data stream that is sent by the host.

**Isochronous Source Endpoint:** An endpoint that is capable of producing an isochronous data stream and sending it to the host.

**Isochronous Transfer:** One of the four USB transfer types. Isochronous transfers are used when working with isochronous data. Isochronous transfers provide periodic, continuous communication between host and device. See also *transfer type*.

**Jitter:** A tendency toward lack of synchronization caused by mechanical or electrical changes. More specifically, the phase shift of digital pulses over a transmission medium.

**kb/s:** Transmission rate expressed in kilobits per second. A measurement of bandwidth in the U.S.





**kB/s:** Transmission rate expressed in kilobytes per second.

**Little endian:** Method of storing data that places the least significant byte of multiple-byte values at lower storage addresses. For example, a 16-bit integer stored in little endian format places the least significant byte at the lower address and the most significant byte at the next address.

**LOA:** Loss of bus activity characterized by an SOP without a corresponding EOP.

**Low-speed:** USB operation at 1.5 Mb/s. See also *full-speed and high-speed*.

**LSb:** Least significant bit.

**LSB:** Least significant byte.

**LVDS:** Low-voltage differential signal

**MAC:** Multiply Accumulate unit

**Mb/s:** Transmission rate expressed in megabits per second.

**MB/s:** Transmission rate expressed in megabytes per second.

**MC:** Media Center. A combination digital set-top box, video and music jukebox, personal video recorder and an Internet gateway and firewall that hooks up to a broadband connection.

**Message Pipe:** A bidirectional pipe that transfers data using a request/data/status paradigm. The data has an imposed structure that allows requests to be reliably identified and communicated.

**Microframe:** A 125 microsecond time base established on high-speed buses.

**MMC:** Multimedia Card - small form factor memory and I/O card

**MMX Technology:** The Intel® MMX™ technology comprises a set of instructions that are designed to greatly enhance the performance of advanced media and communications applications. See chapter 10 of the *Intel® Architecture Software Developers Manual, Volume 3: System Programming Guide*, Order #245472.

**Mobile Station:** Cellular Telephone handset

**M-PSK:** multilevel phase shift keying. A convention for encoding digital data in which there are multiple states.

**MMU:** Memory Management Unit, part of the Intel XScale® core.

**MSb:** Most significant bit.

**MSB:** Most significant byte.

**MSL:** Mobile Scalable Link.

**NAK:** Handshake packet indicating a negative acknowledgment.

**Non Return to Zero Invert (NRZI):** A method of encoding serial data in which ones and zeroes are represented by opposite and alternating high and low voltages where there is no return to zero (reference) voltage between encoded bits. Eliminates the need for clock pulses.

**NRZI:** See Non Return to Zero Invert.

**Object:** Host software or data structure representing a USB entity.





**OFDM:** See Orthogonal Frequency Division Multiplexing.

**Orthogonal Frequency Division Multiplexing:** A special form of multi-carrier modulation. In a multi-path channel, most conventional modulation techniques are sensitive to inter-symbol interference unless the channel symbol rate is small compared to the delay spread of the channel. OFDM is significantly less sensitive to inter-symbol interference, because a special set of signals is used to build the composite transmitted signal. The basic idea is that each bit occupies a frequency-time window that ensures little or no distortion of the waveform. In practice, it means that bits are transmitted in parallel over a number of frequency-nonselective channels.

**Packet:** A bundle of data organized in a group for transmission. Packets typically contain three elements: control information (for example, source, destination, and length), the data to be transferred, and error detection and correction bits. Packet data is the basis for packet-switched networks, which eliminate the need to dial-in to send or receive information, because they are “always on.”

**Packet Buffer:** The logical buffer used by a USB device for sending or receiving a single packet. This determines the maximum packet size the device can send or receive.

**Packet ID (PID):** A field in a USB packet that indicates the type of packet, and by inference, the format of the packet and the type of error detection applied to the packet.

**Packet Switched Network:** Networks that transfer packets of data.

**PCMCIA:** Personal Computer Memory Card Interface Association (PC Card)

**PCS:** Personal Communications services. An alternative to cellular, PCS works like cellular technology because it sends calls from transmitter to transmitter as a caller moves. But PCS uses its own network, not a cellular network, and offers fewer “blind spots” than cellular, where calls are not available. PCS transmitters are generally closer together than their cellular counterparts.

**PDA:** Personal Digital Assistant. A mobile handheld device that gives users access to text-based information. Users can synchronize their PDAs with a PC or network; some models support wireless communication to retrieve and send e-mail and get information from the Internet.

**Phase:** A token, data, or handshake packet. A transaction has three phases.

**Phase Locked Loop (PLL):** A circuit that acts as a phase detector to keep an oscillator in phase with an incoming frequency.

**Physical Device:** A device that has a physical implementation; for example, speakers, microphones, and CD players.

**PID:** See Packet ID or Process ID.

**PIO:** Programmed input/output

**Pipe:** A logical abstraction representing the association between an endpoint on a device and software on the host. A pipe has several attributes; for example, a pipe may transfer data as streams (stream pipe) or messages (message pipe). See also *stream pipe and message pipe*.

**PLL:** See Phase Locked Loop.

**PM:** Phase Modulation.

**Polling:** Asking multiple devices, one at a time, if they have any data to transmit.

**POR:** See Power On Reset.



**Port:** Point of access to or from a system or circuit. For the USB, the point where a USB device is attached.

**Power On Reset (POR):** Restoring a storage device, register, or memory to a predetermined state when power is applied.

**Process ID:** Process identifier

**Programmable Data Rate:** Either a fixed data rate (single-frequency endpoints), a limited number of data rates (32 kHz, 44.1 kHz, 48 kHz, ...), or a continuously programmable data rate. The exact programming capabilities of an endpoint must be reported in the appropriate class-specific endpoint descriptors.

**Protocol:** A specific set of rules, procedures, or conventions relating to format and timing of data transmission between two devices.

**PSP:** Programmable Serial Protocol

**PWM:** Pulse Width Modulator

**QBS:** Qualification By Similarity. A technique allowed by JEDEC for part qualification when target parameters are fully understood and data exist to warrant omitting a specific test.

**QAM:** quadrature amplitude modulation. A coding scheme for digital data.

**QPSK:** quadrature phase shift keying. A convention for encoding digital data into a signal using phase-modulated communications.

**RA:** See rate adaptation.

**Radio Frequency Device:** These devices use radio frequencies to transmit data. One typical use is for bar code scanning of products in a warehouse or distribution center, and sending that information to an ERP database.

**Rate Adaptation:** The process by which an incoming data stream, sampled at  $F_{s i}$ , is converted to an outgoing data stream, sampled at  $F_{s o}$ , with a certain loss of quality, determined by the rate adaptation algorithm. Error control mechanisms are required for the process.  $F_{s i}$  and  $F_{s o}$  can be different and asynchronous.  $F_{s i}$  is the input data rate of the RA;  $F_{s o}$  is the output data rate of the RA.

**Request:** A request made to a USB device contained within the data portion of a SETUP packet.

**Retire:** The action of completing service for a transfer and notifying the appropriate software client of the completion.

**RGBT:** Red, Green, Blue, Transparency

**ROM:** Read Only Memory.

**Root Hub:** A USB hub directly attached to the Host controller. This hub (tier 1) is attached to the host.

**Root Port:** The downstream port on a Root Hub.

**RTC:** Real-Time Clock

**SA-1110:** StrongARM\* based applications processor for handheld products

**Intel® StrongARM\* SA-1111:** Companion chip for the Intel® SA-1110 processor

**SAD:** Sum of absolute differences



**Sample:** The smallest unit of data on which an endpoint operates; a property of an endpoint.

**Sample Rate (Fs):** The number of samples per second, expressed in Hertz (Hz).

**Sample Rate Conversion (SRC):** A dedicated implementation of the RA process for use on sampled analog data streams. The error control mechanism is replaced by interpolating techniques. Service A procedure provided by a System Programming Interface (SPI).

**Satellite Phone:** Phones that connect callers by satellite. Users have a world-wide alternative to terrestrial connections. Typical use is for isolated users, such as crews of deep-sea oil rigs with phones configured to connect to a satellite service.

**SAV:** Start of active video

**SAW:** Surface Acoustic Wave filter

**SDRAM:** Synchronous Dynamic Random Access Memory.

**Service Interval:** The period between consecutive requests to a USB endpoint to send or receive data.

**Service Jitter:** The deviation of service delivery from its scheduled delivery time.

**Service Rate:** The number of services to a given endpoint per unit time.

**SIMD:** Single Instruction Multiple Data (a parallel processing architecture).

**Smart Phone:** A combination of a mobile phone and a PDA, which allow users to communicate as well as perform tasks; such as, accessing the Internet and storing contacts in a database. Smart phones have a PDA-like screen.

**SMROM:** Synchronous Mask ROM

**SMS:** Short Messaging Service. A service through which users can send text-based messages from one device to another. The message can be up to 160 characters and appears on the screen of the receiving device. SMS works with GSM networks.

**SOC:** System On Chip

**SOF:** See Start-of-Frame.

**SOP:** Start-of-Packet.

**SPI:** See System Programming Interface. Also, "Serial Peripheral Interface protocol.

**SPI:** Serial Peripheral Interface

**Split transaction:** A transaction type supported by host controllers and hubs. This transaction type allows full- and low-speed devices to be attached to hubs operating at high-speed.

**Spread Spectrum:** An encoding technique patented by actress Hedy Lamarr and composer George Antheil, which broadcasts a signal over a range of frequencies.

**SRAM:** Static Random Access Memory.

**SRC:** See Sample Rate Conversion.

**SSE:** Streaming SIMD Extensions



**SSE2:** Streaming SIMD Extensions 2: for Intel Architecture machines, 144 new instructions, a 128-bit SIMD integer arithmetic and 128-bit SIMD double precision floating point instructions, enabling enhanced multimedia experiences.

**SSP:** Synchronous Serial Port

**SSTL:** Stub series terminated logic

**Stage:** One part of the sequence composing a control transfer; stages include the Setup stage, the Data stage, and the Status stage.

**Start-of-Frame (SOF):** The first transaction in each (micro)frame. An SOF allows endpoints to identify the start of the (micro)frame and synchronize internal endpoint clocks to the host.

**Stream Pipe:** A pipe that transfers data as a stream of samples with no defined USB structure

**SWI:** Software interrupt.

**Synchronization Type:** A classification that characterizes an isochronous endpoint's capability to connect to other isochronous endpoints.

**Synchronous RA:** The incoming data rate,  $F_{si}$ , and the outgoing data rate,  $F_{so}$ , of the RA process are derived from the same master clock. There is a fixed relation between  $F_{si}$  and  $F_{so}$ .

**Synchronous SRC:** The incoming sample rate,  $F_{si}$ , and outgoing sample rate,  $F_{so}$ , of the SRC process are derived from the same master clock. There is a fixed relation between  $F_{si}$  and  $F_{so}$ .

**System Programming Interface (SPI):** A defined interface to services provided by system software.

**TC:** Temperature Cycling

**TDD:** Time Division Duplexing The Mobile Station and the Base Station transmit on same frequency at different times.

**TDM:** See Time Division Multiplexing.

**TDMA:** Time Division Multiple Access. TDMA protocol allows multiple users to access a single radio frequency by allocating time slots for use to multiple voice or data calls. TDMA breaks down data transmissions, such as a phone conversation, into fragments and transmits each fragment in a short burst, assigning each fragment a time slot. With a cell phone, the caller would not detect this fragmentation. TDMA works with GSM and digital cellular services.

**TDR:** See Time Domain Reflectometer.

**Termination:** Passive components attached at the end of cables to prevent signals from being reflected or echoed.

**TFT:** Thin Film Twist, a type of active LCD panel.

**Three-state:** a high-impedance state in which the output is floating and is electrically isolated from the buffer's circuitry.

**Time Division Multiplexing (TDM):** A method of transmitting multiple signals (data, voice, and/or video) simultaneously over one communications medium by interleaving a piece of each signal one after another.

**Time Domain Reflectometer (TDR):** An instrument capable of measuring impedance characteristics of the USB signal lines.



**Time-out:** The detection of a lack of bus activity for some predetermined interval.

**Token Packet:** A type of packet that identifies what transaction is to be performed on the bus.

**TPV:** Third Party Vendor

**Transaction:** The delivery of service to an endpoint; consists of a token packet, optional data packet, and optional handshake packet. Specific packets are allowed/required based on the transaction type.

**Transaction translator:** A functional component of a USB hub. The Transaction Translator responds to special high-speed transactions and translates them to full/low-speed transactions with full/low-speed devices attached on downstream facing ports.

**Transfer:** One or more bus transactions to move information between a software client and its function.

**Transfer Type:** Determines the characteristics of the data flow between a software client and its function. Four standard transfer types are defined: control, interrupt, bulk, and isochronous.

**TS:** Thermal Shock

**Turn-around Time:** The time a device needs to wait to begin transmitting a packet after a packet has been received to prevent collisions on the USB. This time is based on the length and propagation delay characteristics of the cable and the location of the transmitting device in relation to other devices on the USB.

**UART:** Universal Asynchronous Receiver/Transmitter serial port

**Universal Serial Bus Driver (USBD):** The host resident software entity responsible for providing common services to clients that are manipulating one or more functions on one or more Host controllers.

**Universal Serial Bus Resources:** Resources provided by the USB, such as bandwidth and power. See also *Device Resources and Host Resources*.

**Upstream:** The direction of data flow towards the host. An upstream port is the port on a device electrically closest to the host that generates upstream data traffic from the hub. Upstream ports receive downstream data traffic.

**USBD:** See **Universal Serial Bus Driver**.

**USB-IF:** USB Implementers Forum, Inc. is a nonprofit corporation formed to facilitate the development of USB compliant products and promote the technology.

**VBI:** Vertical Blanking Interval, also known as the “backporch”.

**Virtual Device:** A device that is represented by a software interface layer. An example of a virtual device is a hard disk with its associated device driver and client software that makes it able to reproduce an audio.WAV file.

**VLIO:** Variable Latency Input/Output interface.

**YUV:** A method of characterizing video signals typically used in digital cameras and PAL television specifying luminance and chrominance.

**WAP:** Wireless Application Protocol. WAP is a set of protocols that lets users of mobile phones and other digital wireless devices access Internet content, check voice mail and e-mail, receive text of faxes and conduct transactions. WAP works with multiple standards, including CDMA and GSM. Not all mobile devices support WAP.



**W-CDMA:** Wideband CDMA, a third generation wireless technology under development that allows for high-speed, high-quality data transmission. Derived from CDMA, W-CDMA digitizes and transmits wireless data over a broad range of frequencies. It requires more bandwidth than CDMA, but offers faster transmission because it optimizes the use of multiple wireless signals, instead of one, as does CDMA.

**Wireless LAN:** A wireless LAN uses radio frequency technology to transmit network messages through the air for relatively short distances, like across an office building or a college campus. A wireless LAN can serve as a replacement for, or an extension to, a traditional wired LAN.

**Wireless Spectrum:** A band of frequencies where wireless signals travel carrying voice and data information.

**Word:** A data element that is four bytes (32 bits) in size.

**WML:** Wireless Markup Language, a version of HDML is based on XML. Wireless applications developers use WML to re-target content for wireless devices.

§§

**A**

- About This Document 1-1
- AC Timing Specifications 6-1
  - AC Test Load Specifications 6-1
  - GPIO Timing Specifications 6-11
  - JTAG Boundary Scan Timing Specifications 6-45
  - LCD Timing Specifications 6-43
  - Memory and Expansion-Card Timing Specifications 6-12
    - Flash Memory Parameters and Timing Diagrams 6-23
    - SRAM Parameters and Timing Diagrams 6-33
    - Variable-Latency I/O Parameters and Timing Diagrams 6-36
- Reset and Power Manager Timing Specifications 6-2
  - Deep-Sleep Mode Timing 6-7
  - Frequency-Change Timing 6-10
  - GPIO Reset Timing 6-5
  - Hardware Reset Timing 6-4
  - Idle-Mode Timing 6-10
  - Sleep Mode Timing 6-6
  - Standby-Mode Timing 6-10
  - Voltage-Change Timing 6-11
  - Watchdog Reset Timing 6-5
- SSP Timing Specifications 6-44
- Applicable Documents 1-2

**E**

- Electrical Specifications 5-1
  - Absolute Maximum Ratings 5-1
  - CLK\_PIO and CLK\_TOUT Specifications 5- 9
  - DC Specification 5-6
  - Operating Conditions 5-1
  - Oscillator Electrical Specifications 5-6
    - 13.000-MHz Oscillator Specifications 5-8
    - 32.768-kHz Oscillator Specifications 5-7
  - Power-Consumption Specifications 5-5
- Expansion-Card Interface Parameters and Timing Diagrams 6-40

**F**

- Flash Memory Read Parameters and Timing Diagrams 6-23

- Flash Memory Write Parameters and Timing Diagrams 6-30
- Functional Overview 2-1

**G**

- GPIO states in Deep-Sleep mode 6-9

**I**

- Internal SRAM Read/Write Timing Specifications 6-12
- Introduction 1-1
  - About This Document 1-1
  - Applicable Documents 1-2
  - Number Representation 1-1
  - Typographical Conventions 1-1

**J**

- Junction To Case Temperature Thermal Resistance 3-3

**N**

- Number Representation 1-1

**P**

- Package Information 1-1
- Pinlist 4-1
- Power-On Timing Specifications 6-2
- Processor Markings 3-3
- Processor Materials 3-2

**R**

- ROM Parameters and Timing Diagrams 18

**S**

- SDRAM Parameters and Timing Diagrams 6-12
- SRAM Read Parameters and Timing Diagrams 6-33
- SRAM Write Parameters and Timing Diagrams 6-33

**T**

- Tray Drawing 3-5
- Typographical Conventions 1-1

**V**

- Variable Latency I/O Read Timing 6-37
- Variable-Latency I/O Write Timing 6-38

