

Typical Applications

The HMC441LP3 / HMC441LP3E is a medium PA for:

- Point-to-Point Radios
- Point-to-Multi-Point Radios
- VSAT
- LO Driver for HMC Mixers
- Military EW & ECM

Features

- Gain: 14 dB
- Saturated Power: +20 dBm @ 20% PAE
- Single Supply Voltage: +5V w/ Optional Gate Bias
- 50 Ohm Matched Input/Output
- 16 Lead 3x3mm SMT Package: 9mm²

Functional Diagram

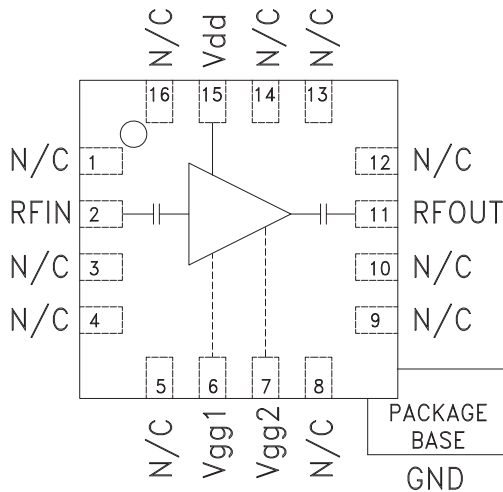

TOP VIEW

Vgg1, Vgg2: Optional Gate Bias

General Description

The HMC441LP3 & HMC441LP3E are broadband GaAs PHEMT MMIC Medium Power Amplifiers which operate between 6.5 and 13.5 GHz. The leadless plastic QFN surface mount packaged amplifier provides 14 dB of gain, +20 dBm saturated power at 20% PAE from a +5V supply voltage. An optional gate bias is provided to allow adjustment of gain, RF output power, and DC power dissipation. This 50 Ohm matched amplifier does not require any external components making it an ideal linear gain block or driver for HMC SMT mixers.

Electrical Specifications, $T_A = +25^\circ\text{C}$, $V_{dd} = 5\text{V}$, $V_{gg1} = V_{gg2} = \text{Open}$

| Parameter | Min. | Typ. | Max. | Min. | Typ. | Max. | Min. | Typ. | Max. | Units |
|--|-----------|------|-------|------------|------|-------|-------------|------|-------|-------|
| Frequency Range | 6.5 - 8.0 | | | 8.0 - 11.0 | | | 11.0 - 13.5 | | | GHz |
| Gain | 10 | 13 | | 12 | 14 | | 10 | 13 | | dB |
| Gain Variation Over Temperature | | 0.02 | 0.025 | | 0.02 | 0.025 | | 0.02 | 0.025 | dB/°C |
| Input Return Loss | | 12 | | | 15 | | | 14 | | dB |
| Output Return Loss | | 12 | | | 15 | | | 13 | | dB |
| Output Power for 1 dB Compression (P1dB) | 13 | 16 | | 15 | 18 | | 14 | 17 | | dBm |
| Saturated Output Power (P _{sat}) | | 18.5 | | | 20 | | | 19.5 | | dBm |
| Output Third Order Intercept (IP3) | 23 | 26 | | 26 | 29 | | 26 | 29 | | dBm |
| Noise Figure | | 5.0 | | | 4.5 | | | 4.75 | | dB |
| Supply Current (I _{dd}) | | 90 | 115 | | 90 | 115 | | 90 | 115 | mA |



HMC441LP3 / 441LP3E

GaAs PHEMT MMIC MEDIUM POWER AMPLIFIER, 6.5 - 13.5 GHz

Broadband Gain & Return Loss

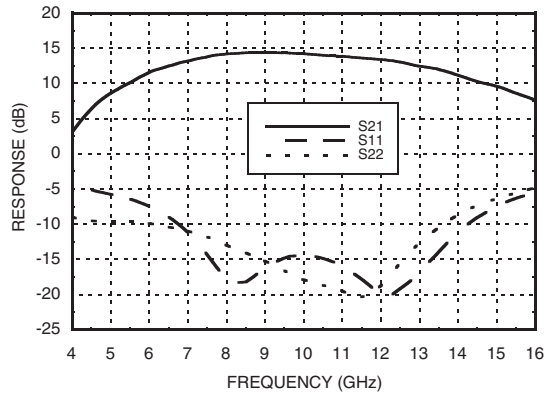

Gain vs. Temperature

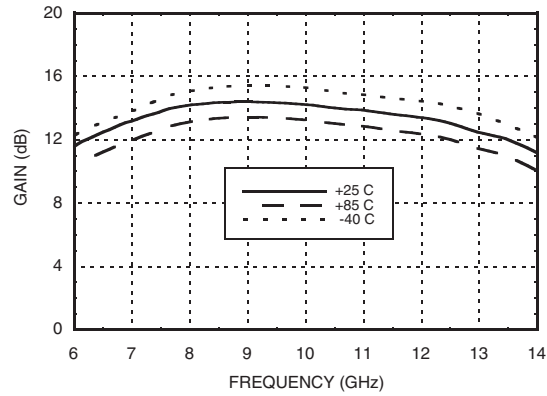

Input Return Loss vs. Temperature

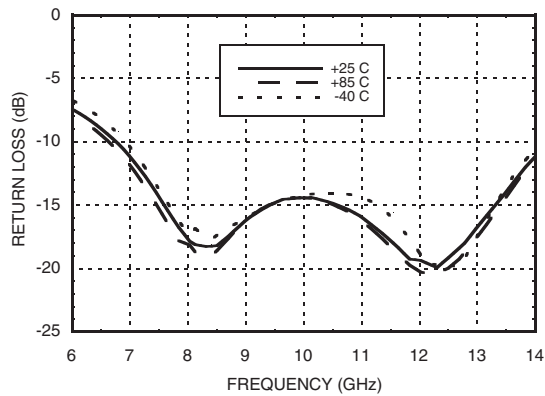

Output Return Loss vs. Temperature

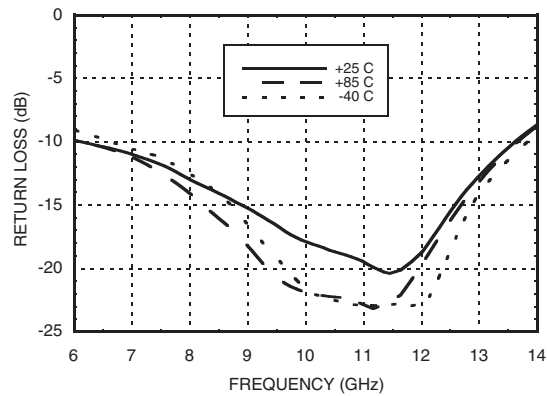

P1dB vs. Temperature

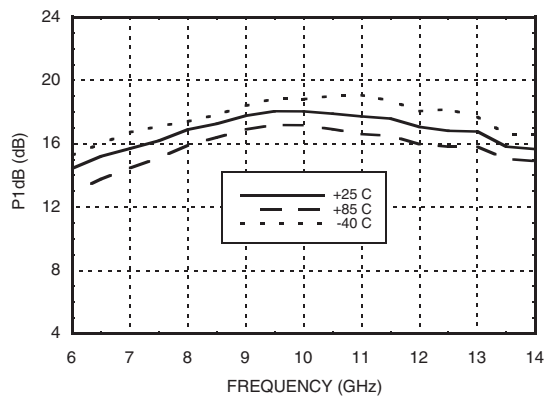

Psat vs. Temperature

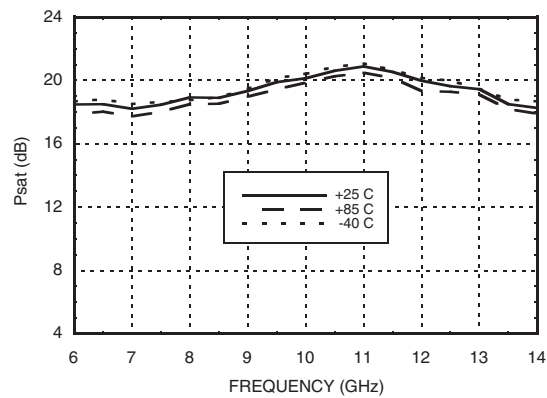

11

LINEAR & POWER AMPLIFIERS - SMT



HMC441LP3 / 441LP3E

GaAs PHEMT MMIC MEDIUM POWER AMPLIFIER, 6.5 - 13.5 GHz

11

LINEAR & POWER AMPLIFIERS - SMT

Power Compression @ 10 GHz

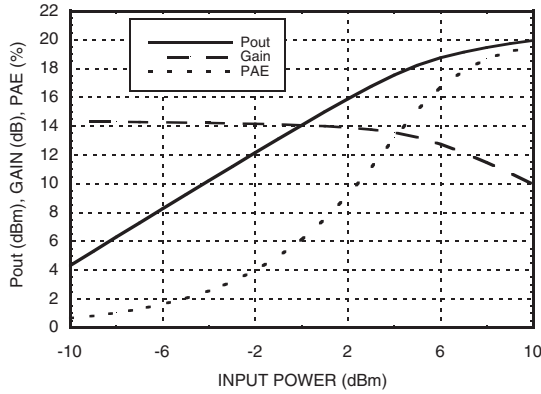

Output IP3 vs. Temperature

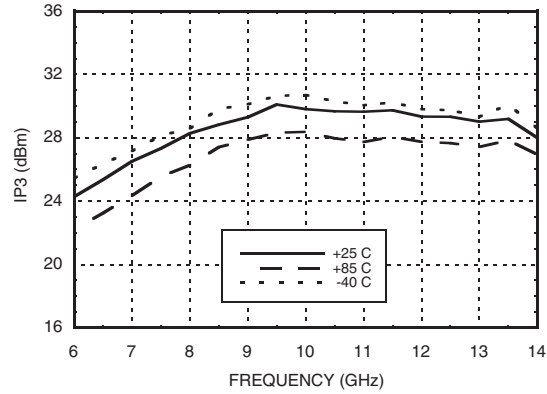

Gain, Power & Output IP3 vs. Supply Voltage @ 10 GHz

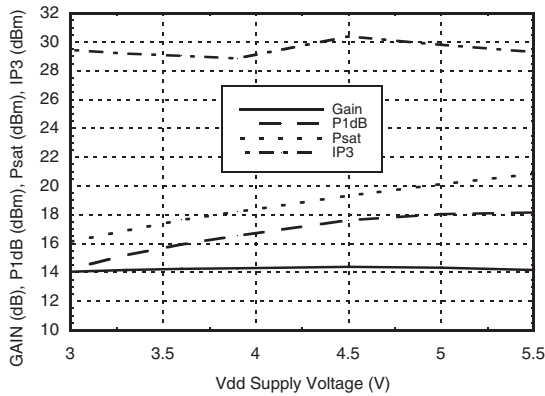

Gain, Power & I_{dd} vs. Gate Voltage @ 10 GHz

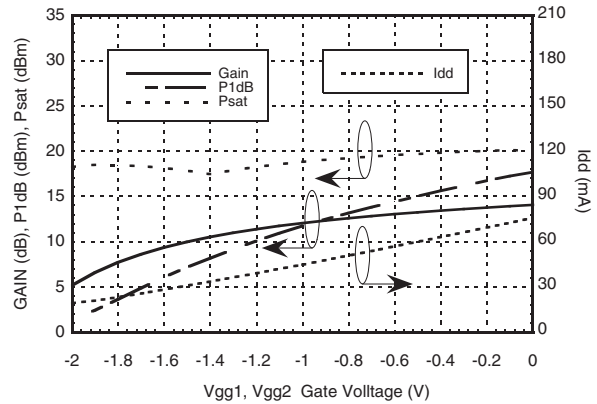

Noise Figure vs. Temperature

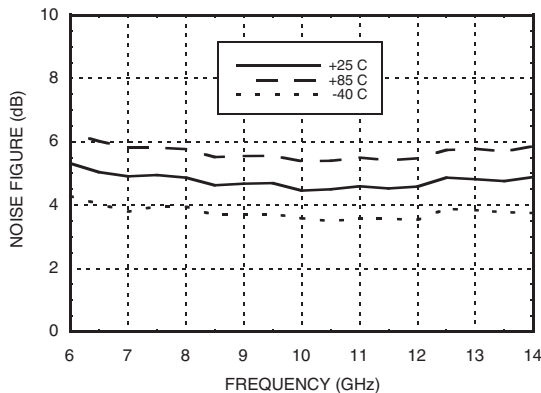

Reverse Isolation vs. Temperature

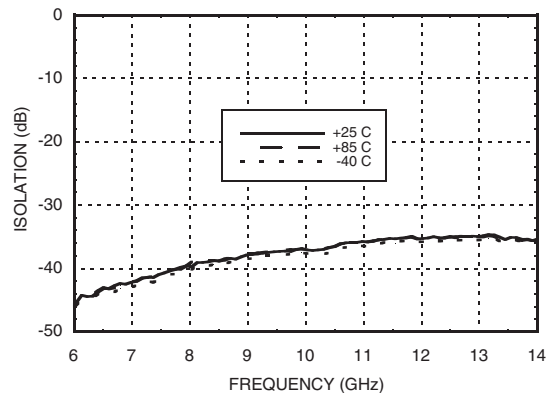

Absolute Maximum Ratings

| | |
|--|----------------|
| Drain Bias Voltage (Vdd) | +6 Vdc |
| Gate Bias Voltage (Vgg1,Vgg2) | -8 to 0 Vdc |
| RF Input Power (RFIN)(Vdd = +5 Vdc) | +15 dBm |
| Channel Temperature | 175 °C |
| Continuous Pdiss (T = 85 °C) (derate 8.5 mW/°C above 85 °C) | 0.76 W |
| Thermal Resistance (channel to ground paddle) | 118.2 °C/W |
| Storage Temperature | -65 to +150 °C |
| Operating Temperature | -40 to +85 °C |

Typical Supply Current vs. Vdd

| Vdd (V) | Idd (mA) |
|---------|----------|
| +5.5 | 92 |
| +5.0 | 90 |
| +4.5 | 88 |
| +3.3 | 83 |
| +3.0 | 82 |

Note: Amplifier will operate over full voltage range shown above



ELECTROSTATIC SENSITIVE DEVICE
OBSERVE HANDLING PRECAUTIONS

Outline Drawing

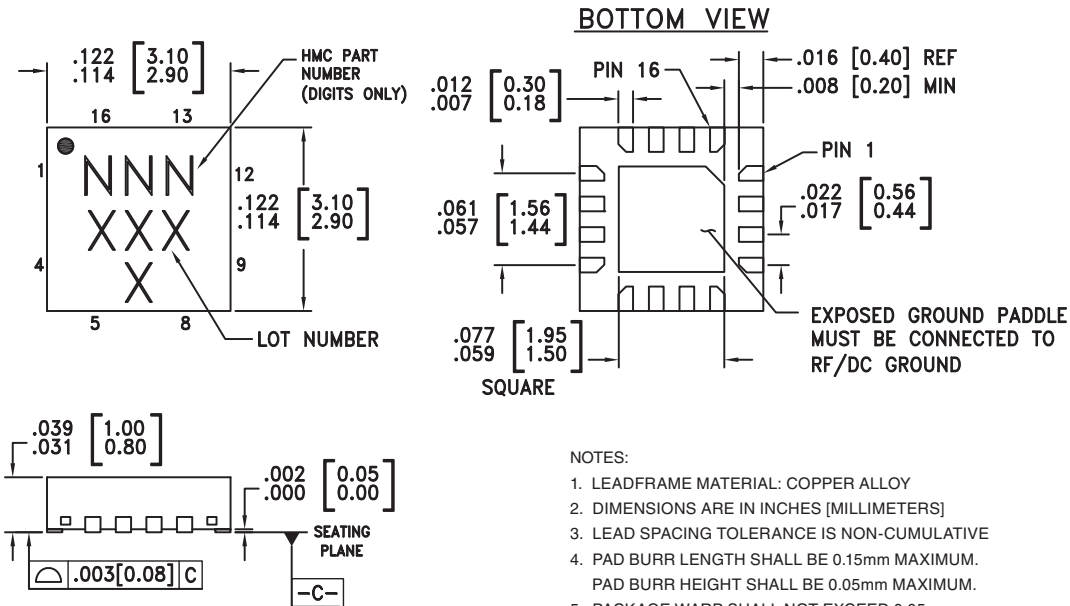

NOTES:

1. LEADFRAME MATERIAL: COPPER ALLOY
2. DIMENSIONS ARE IN INCHES [MILLIMETERS]
3. LEAD SPACING TOLERANCE IS NON-CUMULATIVE
4. PAD BURR LENGTH SHALL BE 0.15mm MAXIMUM. PAD BURR HEIGHT SHALL BE 0.05mm MAXIMUM.
5. PACKAGE WARP SHALL NOT EXCEED 0.05mm.
6. ALL GROUND LEADS AND GROUND PADDLE MUST BE SOLDERED TO PCB RF GROUND.
7. REFER TO HITTITE APPLICATION NOTE FOR SUGGESTED LAND PATTERN.

Package Information

| Part Number | Package Body Material | Lead Finish | MSL Rating | Package Marking ^[3] |
|-------------|--|---------------|---------------------|--------------------------------|
| HMC441LP3 | Low Stress Injection Molded Plastic | Sn/Pb Solder | MSL1 ^[1] | 441 XXXX |
| HMC441LP3E | RoHS-compliant Low Stress Injection Molded Plastic | 100% matte Sn | MSL1 ^[2] | 441 XXXX |



[1] Max peak reflow temperature of 235 °C

[2] Max peak reflow temperature of 260 °C

[3] 4-Digit lot number XXXX

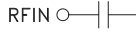
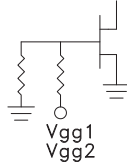
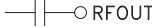
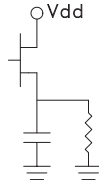

Pin Descriptions

| Pin Number | Function | Description | Interface Schematic |
|-------------------------|------------|--|--|
| 1, 3-5, 8-10, 12-14, 16 | N/C | This pin may be connected to RF/DC ground. | |
| 2 | RFIN | This pin is AC coupled and matched to 50 Ohms. | RFIN  |
| 6, 7 | Vgg1, Vgg2 | Optional gate control for amplifier. If left open, the amplifier will run at standard current. Negative voltage applied will reduce current. |  |
| 11 | RFOUT | This pin is AC coupled and matched to 50 Ohms. |  |
| 15 | Vdd | Power Supply Voltage for the amplifier. An external bypass capacitor of 100 pF is required. |  |
| | GND | Package bottom must be connected to RF/DC ground. |  |

Evaluation PCB

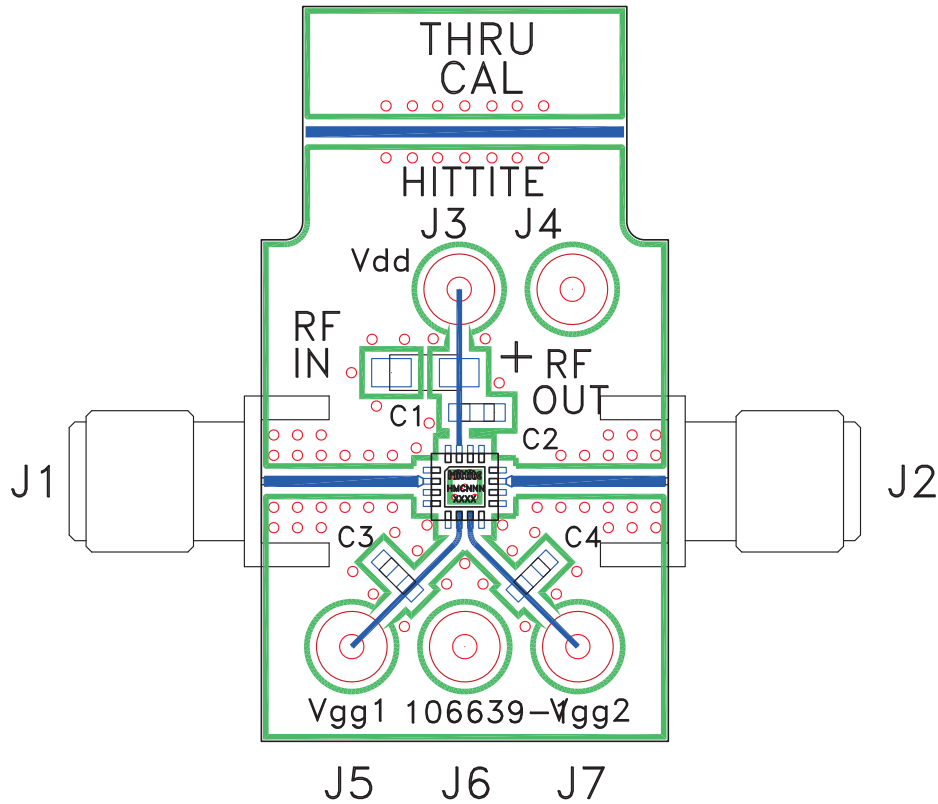

List of Materials for Evaluation PCB 106705 [1]

| Item | Description |
|---------|----------------------------------|
| J1 - J2 | PCB Mount SMA Connector |
| J3 - J7 | DC Pin |
| C1 | 4.7 μ F Capacitor, Tantalum |
| C2 - C4 | 100 pF Capacitor, 0402 Pkg. |
| U1 | HMC441LP3 / HMC441LP3E Amplifier |
| PCB [2] | 106639 Evaluation PCB, 10 mils |

[1] Reference this number when ordering complete evaluation PCB

[2] Circuit Board Material: Rogers 4350

The circuit board used in the final application should use RF circuit design techniques. Signal lines should have 50 ohm impedance while the package ground leads and exposed paddle should be connected directly to the ground plane similar to that shown. A sufficient number of via holes should be used to connect the top and bottom ground planes. The evaluation board should be mounted to an appropriate heat sink. The evaluation circuit board shown is available from Hittite upon request.