

MeshConnect™ EM357 Module

ZICM357P2-1

Ember EM357 Transceiver Based Module

Integrated Transceiver Modules for ZigBee / IEEE 802.15.4
Development Kit available: ZICM357P2-KIT1-1

DESCRIPTION

CEL's MeshConnect™ EM357 Module combines high performance RF solution with the market's premier ZigBee stack. The addition of on board memory enables Over-The-Air (OTA) programming without the need for additional in system memory. The integrated power amplifier maximizes range and performance. The small module footprint makes it suitable for a wide range of ZigBee applications. The MeshConnect EM357 module is certified and qualified enabling customers to accelerate time to market by greatly reducing the design and certification phases of development.

CEL's MeshConnect™ EM357 module (ZICM357P2-1) is based on the Ember EM357 Zigbee compliant SOC IC. The IC is a single-chip solution, compliant with ZigBee specifications and IEEE 802.15.4, a complete wireless solution for all ZigBee applications. The IC consists of an RF transceiver with the baseband modem, a hardwired MAC and an embedded 32-bit ARM® Cortex™-M3 microcontroller with internal RAM (12kB) and Flash (192kB) memory. The device provides numerous general-purpose I/O pins and peripheral functions such as timers and UARTs.

The MeshConnect EM357 module adds a power amplifier (PA) to increase range up to 2.5 miles, provide more reliable transmission, and reduce the number of nodes in your network. It is especially useful for open outdoor applications where the nodes are physically far apart or for indoor use where the nodes have to operate in a noisy RF environment. The Module's outstanding 120dB link budget ensures high quality connections even in such harsh environments.

The MeshConnect EM357 module also integrates an *1MB Flash memory for Over-The-Air program updates*, making this device ready for Smart Energy Applications.

ORDERING INFORMATION

Part Number	Order Number	Description
MeshConnect™ EM357 Module	ZICM357P2-1	+20 dBm Output power, PCB Trace antenna
	ZICM357P2-1C	+20 dBm Output power, with U.FL Connector for external antenna
	ZICM357P2-KIT1-1	+20 dBm Engineering Development Kit



CEL MeshConnect™ EM357 Module

- **FLASH Memory:**
192 kB (EM357 internal)
1MB (on module board)
- **12 kB SRAM**
- **32-bit ARM® Cortex™-M3**
- **Up to 23 GPIO Pins**
- **SPI (Master/Slave), TWI, UART**
- **Timers, Serial Wire/JTAG Interface**
- **5-channel 14-bit ADC**

- Transmit power +20dBm
- 1MB additional flash for Over-The-Air programming
- +120 dB RF link budget
- Range up to 2.5 miles

FEATURES

- **High RF performance:**
 - Up to 120 dB RF Link Budget
 - RX Sensitivity: -100 dBm
 - RF TX Power: +20 dBm
- **Data Rate: 250 kbps**
- **Small footprint: 1" x 1.41"**
(25.4 mm x 35.9 mm)
- **Advanced Power Management**
Scheme w/ Deep Sleep Mode
- **Integrated PCB trace antenna**
Optional U.FL external Antenna
- **15 RF channels**
- **Up to 13,000 feet of range**
- **AES encryption**
- **FCC, CE and IC certifications**
- **ROHS compliant**

APPLICATIONS

- **Smart Energy / Grid Markets**
Smart Meters
- **Building automation and control**
- **Home automation and control**
Thermostats
Displays
Energy Management
Security Devices
HVAC control
Lighting control
- **General ZigBee wireless sensor networking**

MODULE BLOCK DIAGRAM

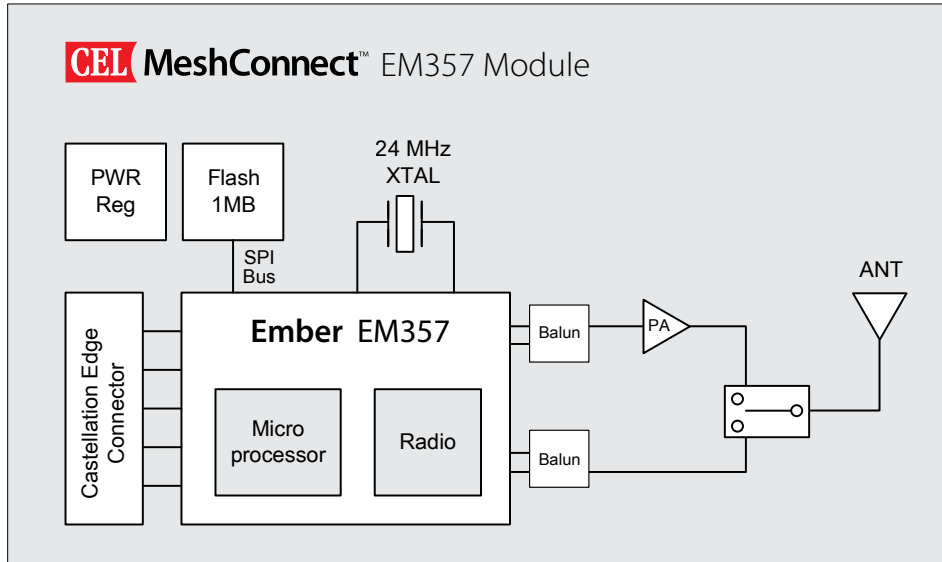

DEVELOPMENT KIT

CEL's Development Kit assists users in both evaluation and development. As a stand-alone radio system, the kit allows users to place the modules into the target environment and evaluate performance on-site. The Development Kit also serves as an invaluable aid in application development. Through the many interface headers on the board, the user has access to all of the MeshConnect module pins, enabling easy connection to target systems for application development.

The interface board features a serial communication interface, a power management module, and peripherals such as a buzzer, a temperature sensor, push-button switches, LEDs, and GPIO headers.

For more detail information regarding MeshConnect Development Kits, refer to the respective development kit user guides documents. (Available at CEL's website <http://www.cel.com>)

CEL MeshConnect™

EM357 Module Development Kit



- Kit Contents:**
- Evaluation Boards w/Module (2)
 - USB Cables (1)
 - AA Batteries (4)
 - Software & Technical Information CD (1)

DEVELOPMENT KIT ORDERING INFORMATION

Part Number	Order Number	Description
MeshConnect™ EM357 Module Development Kit	ZICM357P2-KIT1-1	+20 dBm Engineering Development Kit

TABLE OF CONTENTS

Introduction and Overview

Description.....	1
Features.....	1
Applications.....	1
Ordering Information.....	1
Module Block Diagram.....	2
Development Kit.....	2

System Level Function

Transceiver IC.....	4
Additional Flash Memory.....	4
Antenna.....	4
Power Amplifier.....	4

Electrical Specification

Absolute Maximum Ratings.....	5
Recommended (Operating Condition).....	5
DC Characteristics.....	5
RF Characteristics.....	5

Pin Signal & Interfaces

Pin Signals I/O Configuration.....	6
I/O Pin Assignment.....	6
Software/Firmware.....	8
Module Dimensions.....	9
Module Footprint.....	9

Processing.....	11
-----------------	----

Agency Certifications.....	12
----------------------------	----

Shipment, Storage & Handling.....	14
-----------------------------------	----

References & Revision History.....	15
------------------------------------	----

TRANSCEIVER IC

The MeshConnect EM357 module uses the Ember EM357 transceiver IC. This IC incorporates the RF transceiver with the baseband modem, a hardwired MAC, and an embedded ARM® Cortex™-M3 microcontroller, offering an excellent low cost high performance solution for all IEEE 802.15.4 / ZigBee applications.

For more information about the Ember EM357 IC, visit <http://www.ember.com>

ADDITIONAL FLASH MEMORY

The MeshConnect EM357 module incorporates an additional 1MB external Flash memory for Over-The-Air program updates. The Flash memory communicates over the EM357's second serial controller using SPI. The flash memory is wired to the following castellation pins:

PA0 - SC2MOSI

PA1 - SC2MISO

PA2 - SC2SCLK

PA3 - SC2nSSEL

WP - Flash memory Write Protect line (has internal pull-up resistor, but not connected to the EM357)

The instruction set for the Flash memory is similar to the Micron M25P80. Note that in order to achieve the specified sleep current for the module, it is necessary to send a Deep Power-Down command to the Flash memory.

See <http://www.micron.com> for more information on the instruction set.

ANTENNA

CEL's MeshConnect modules include an integrated Printed Circuit Board (PCB) trace antenna. An optional U.FL connector can be specified, providing connection to a 50-ohm external antenna of the user's choice. See Ordering Information on page 1.

The PCB antenna employs an Inverted F-Antenna topology that is compact and highly efficient. To maximize range, an adequate ground plane must be provided on the host PCB. Correctly positioned, the ground plane on the host PCB will contribute significantly to the antenna performance (it should not be directly under the Inverted F-Antenna). The position of the module on the host board and overall design of the product enclosure contribute to antenna performance. Poor design affects radiation patterns and can result in reflection, diffraction, and/or scattering of the transmitted signal.

Here are some design guidelines to help ensure antenna performance:

- Never place the ground plane or route copper traces directly underneath the antenna portion of the module.
- Never place the antenna close to metallic objects.
- In the overall design, ensure that wiring and other components are not placed near the antenna.
- Do not place the antenna in a metallic or metalized plastic enclosure.
- Keep plastic enclosures 1cm or more from the antenna in any direction.

For optimum antenna performance, the MeshConnect modules should be mounted with the PCB trace antenna overhanging the edge of the host board. To further improve performance, a ground plane may be placed on the host board under the module, up to the antenna. The installation of an uninterrupted ground plane on a layer directly beneath the module will also allow you to run traces under this layer. CEL can provide assistance with your PCB layout.

POWER AMPLIFIER

The MeshConnect EM357 Module includes a Power Amplifier (PA). This PA delivers high efficiency, high gain, and high output power (Pout = +20.0 dBm TYP) to provide an extended range and reliable transmission for fewer nodes in a network.

The PA is connected to the alternate EM357 IC TX output, so EM357 TX power modes 2 or 3 must be used to achieve the specified output power.

ABSOLUTE MAXIMUM RATINGS

Description	MeshConnect™ EM357 Module		Unit
	Min	Max	
Power Supply Voltage (VDD)	-0.3	3.6	VDC
Voltage on any I/O Line	-0.3	VDD + 0.3	VDC
RF Input Power	–	15	dBm
Storage Temperature Range	-40	125	°C
Reflow Soldering Temperature	–	260	°C

Note: Exceeding the maximum ratings may cause permanent damage to the module or devices.

RECOMMENDED (OPERATING CONDITIONS)

Description	MeshConnect™ EM357 Module			Unit
	Min	Typ	Max	
Power Supply Voltage (VDD)	2.7	3.3	3.6	V
Input Frequency	2405	–	2475	MHz
Ambient Temperature Range	-40	25	85	°C

DC CHARACTERISTICS (@ 25°C, VDD = 3.3V, ZICM357P2 TX power mode 2, unless otherwise noted)

Description	MeshConnect™ EM357 Module			Unit
	Min	Typ	Max	
Transmit Mode Current	–	170	–	mA
Receive Mode Current	–	28	–	mA
Sleep Mode Current	–	6	–	µA

RF CHARACTERISTICS (@ 25°C, VDD = 3.3V, ZICM357P2 TX power mode 2, unless otherwise noted)

Description	MeshConnect™ EM357 Module			Unit
	Min	Typ	Max	
General Characteristics				
RF Frequency Range	2405	–	2475	MHz
RF Channels	11	–	25	–
Frequency Error Tolerance	-96.2	–	96.2	kHz
Transmitter				
Maximum Output Power	–	20	–	dBm
Minimum Output Power	–	-40	–	dBm
Offset Error Vector Magnitude	–	15	35	%
Receiver				
Sensitivity (1% PER, boost mode)	–	-100	-94	dBm
Sensitivity (1% PER, normal mode)	–	-98	-92	dBm
Saturation (maximum input level)	0	–	–	dBm

PIN SIGNALS I/O PORT CONFIGURATION

MeshConnect module has 56 edge I/O interfaces for connection to the user's host board. The MeshConnect Module Dimensions shows the layout of the 56 edge castellations.

MeshConnect I/O PIN ASSIGNMENTS

CEL MeshConnect EM357 Module PIN Number	Ember EM357 IC Pin Number	Name	Notes
1	49	GROUND	
2	N/C	WP	Flash memory write protect (internal pull-up)
3	21	PA0	Dedicated as SC2MOSI due to Flash memory
4	22	PA1	Dedicated as SC2MISO due to Flash memory
5	24	PA2	Dedicated as SC2SCLK due to Flash memory
6	25	PA3	Reserved as SC2nSSEL for Flash memory
7	49	GROUND	
8	16, 23, 28, 37	VCC	
9	12	RESET	Active Low (Input)
10	13	PC6	Digital I/O OSC32B - 32.768 kHz crystal oscillator nTX_ACTIVE - Inverted TX_ACTIVE signal
11	14	PC7	Digital I/O OSC32A - 32.768 kHz crystal oscillator OSC32_EXT - Digital 32.768 kHz clock input source
12	18	PA7	Digital I/O TIM1C4 - Timer 1 Channel 4 output TIM1C4 - Timer 1 Channel 4 input REG_EN - External regulator open drain output
13	19	PB3	Digital I/O TIM2C3 - Timer 2 channel 3 output TIM2C3 - Timer 2 channel 3 input SC1nCTS - UART CTS handshake of Serial Controller 1 SC1SCLK - SPI master/slave clock of Serial Controller 1
14	20	PB4	Digital I/O TIM2C4 - Timer 2 channel 4 output TIM2C4 - Timer 2 channel 4 input SC1nRTS - UART RTS handshake of Serial Controller 1 SC1nSSEL - SPI slave select of Serial Controller 1
15	26	PA4	Digital I/O ADC4 - ADC Input 4 PTI_EN - Frame signal of Packet Trace Interface (PTI) TRACEDATA2 - Synchronous CPU trace data bit 2
16	27	PA5	Digital I/O ADC5 - ADC Input 5 PTI_DATA - Data signal of Packet Trace Interface (PTI) nBOOTMODE - Embedded serial bootloader activation out of rest TRACEDATA3 - Synchronous CPU trace data bit 3
17	29	PA6	Digital I/O TIM1C3 - Timer 1 channel 3 output TIM1C3 - Timer 1 channel 3 input

MeshConnect I/O PIN ASSIGNMENTS (Continued)

CEL MeshConnect EM357 Module PIN Number	Ember EM357 IC Pin Number	Name	Notes
18	30	PB1	Digital I/O SC1MISO - SPI slave data out of Serial Controller 1 SC1MOSI - SPI master data out of Serial Controller 1 SC1SDA - TWI data of Serial Controller 1 SC1TXD - UART transmit data of Serial Controller 1 TIM2C1 - Timer 2 channel 1 output TIM2C1 - Timer 2 channel 1 input
19	49	GROUND	
20	49	GROUND	
21	49	GROUND	
22	31	PB2	Digital I/O SC1MISO - SPI master data in of Serial Controller 1 SC1MOSI - SPI slave data in of Serial Controller 1 SC1SCL - TWI clock of Serial Controller 1 SC1RXD - UART receive data of Serial Controller 1 TIM2C2 - Timer 2 channel 2 output TIM2C2 - Timer 2 channel 2 input
23	32	JTCK	JTAG clock input from debugger SWCLK - Serial Wire clock input/output with debugger
24	33	PC2	Digital I/O JTDO - JTAG data out to debugger SWO - Serial Wire Output asynchronous trace output to debugger
25		NC	No connect
26	34	PC3	Digital I/O JTDI - JTAG data in from debugger
27	35	PC4	Digital I/O JTMS - JTAG mode select from debugger SWDIO - Serial Wire bidirectional data to/from debugger
28	49	GROUND	
29	36	PB0	Digital I/O VREF - ADC reference output VREF - ADC reference input IRQA - External interrupt source A TRACECLK - Synchronous CPU trace clock TIM1CLK - Timer 1 external clock input TIM2MSK - Timer 2 external clock mask input
30	38	PC1	cc
31	40	PC0	Digital I/O JRST - JTAG reset input from debugger IRQD - Default external interrupt source D TRACEDATA1 - Synchronous CPU trace data bit 1
32		NC	No connect
33	41	PB7	Digital I/O ADC2 - ADC Input 2 IRQC - Default external interrupt source C TIM1C2 - Timer 1 channel 2 output TIM1C2 - Timer 1 channel 2 input

MeshConnect I/O PIN ASSIGNMENTS (Continued)

CEL MeshConnect EM357 Module PIN Number	Ember EM357 IC Pin Number	Name	Notes
34	42	PB6	Digital I/O ADC1 - ADC Input 1 IRQB - External interrupt source B TIM1C1 - Timer 1 channel 1 output TIM1C1 - Timer 1 channel 1 input
35	43	PB5	Digital I/O ADC0 - ADC Input 0 TIM2CLK - Timer 2 external clock input TIM1MSK - Timer 1 external clock mask input
36	49	GROUND	
37	49	GROUND	
38	49	GROUND	
39		NC	No connect
40		NC	No connect
41		NC	No connect
42		NC	No connect
43		NC	No connect
44		NC	No connect
45	49	GROUND	
46	49	GROUND	
47	49	GROUND	
48	49	GROUND	
49	49	GROUND	
50	49	GROUND	
51	49	GROUND	
52	49	GROUND	
53	49	GROUND	
54	49	GROUND	
55	49	GROUND	
56	49	GROUND	

Note: PC5 is not brought out to a castellation since it is required to control the PA.

For additional Pin-out details please reference Ember's EM357 IC Data sheet.

SOFTWARE/FIRMWARE

The MeshConnect EM357 Module is an ideal platform for the EmberZNet PRO, the industry's most deployed and field proven ZigBee compliant stack supporting the ZigBee PRO feature Set. EmberZNET PRO is a complete ZigBee protocol software package containing all the elements required for mesh networking applications. For more information regarding the software development for this IC, visit <http://www.ember.com>

The MeshConnect Development Kit provides a guide on how to access the EM357 IC and utilize the Ember software development environment. It also provides a point to point demo application (transfer data between 2 devices) to conduct a range test and supports low level peripheral tests.

MODULE DIMENSIONS

MeshConnect™ EM357 Module w/PCB Trace Antenna

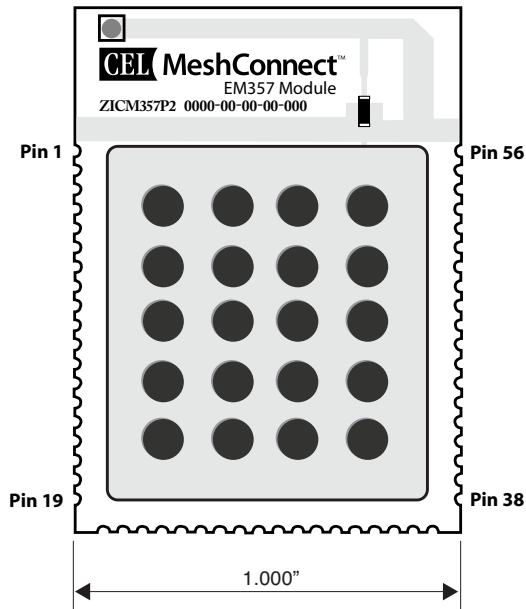

TOP VIEW

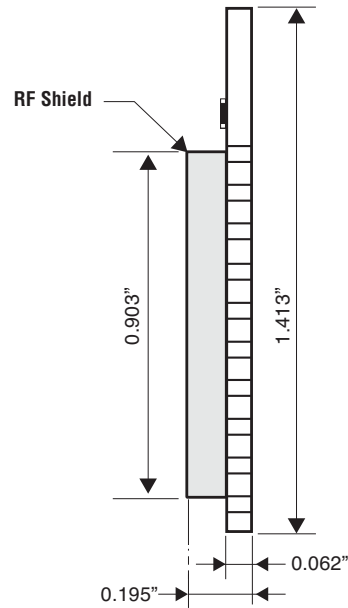

SIDE VIEW

MeshConnect™ EM357 Module w/U.FL Connector for external antenna

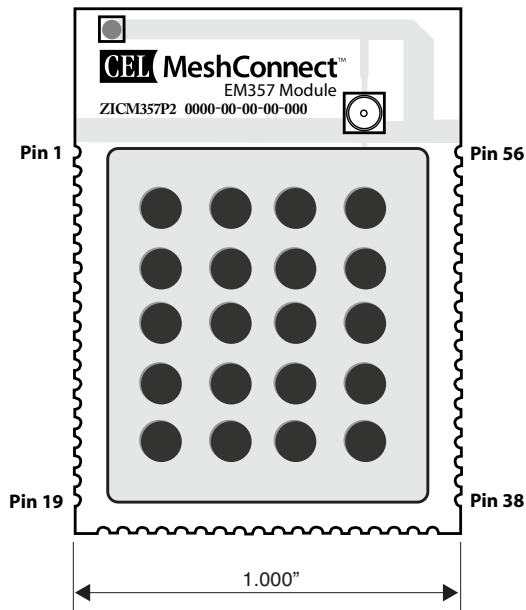

TOP VIEW

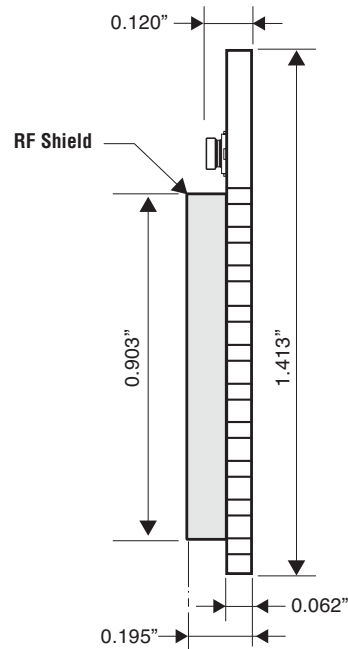

SIDE VIEW

For layout recommendation for optimum antenna performance, refer to Antenna section in this document.

MODULE LAND FOOTPRINT

Note: Unless otherwise specified. Dimensions are in Inches [mm].

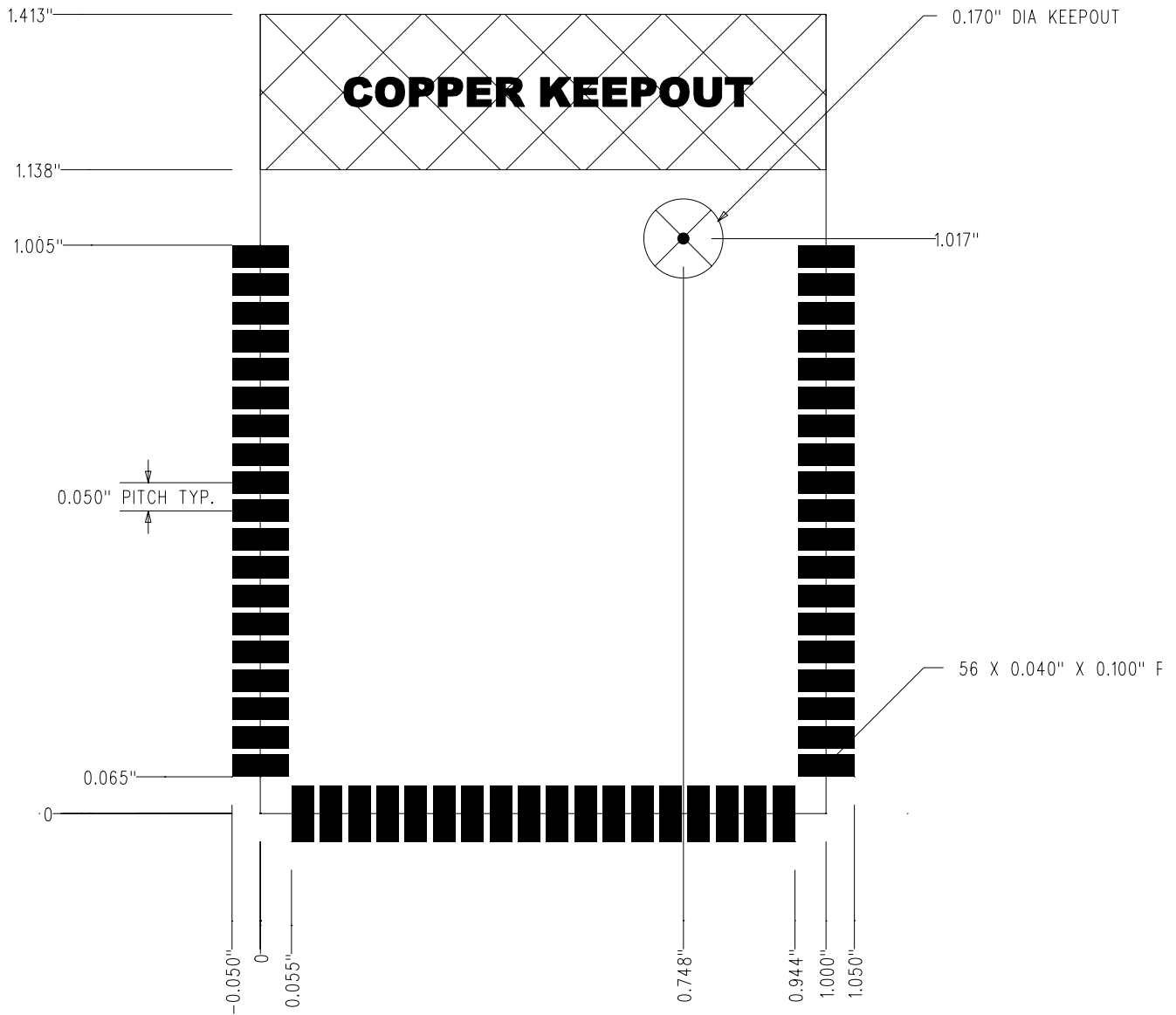

PROCESSING

Recommended Reflow Profile

Parameters Values	
Ramp up rate (from Tsoakmax to Tpeak)	3°/sec max
Minimum Soak Temperature	150°C
Maximum Soak Temperature	200°C
Soak Time	60-120 sec
TLiquidus	217°C
Time above TL	60-150 sec
Tpeak	250°C
Time within 5° of Tpeak	20-30 sec
Time from 25° to Tpeak	8 min max
Ramp down rate	6°C/sec max

Pb-Free Solder Paste

Use of “No Clean” soldering paste is strongly recommended, as it does not require cleaning after the soldering process.

Note: The quality of solder joints on the castellations (‘half vias’) where they contact the host board should meet the appropriate IPC Specification. See the latest **IPC-A-610** Acceptability of Electronic Assemblies, Castellated Terminations section.

Cleaning

In general, cleaning the populated modules is strongly discouraged. Residuals under the module cannot be easily removed with any cleaning process.

- Cleaning with water can lead to capillary effects where water is absorbed into the gap between the host board and the module. The combination of soldering flux residuals and encapsulated water could lead to short circuits between neighboring pads. Water could also damage any stickers or labels.
- Cleaning with alcohol or a similar organic solvent will likely flood soldering flux residuals into the two housings, which is not accessible for post-washing inspection. The solvent could also damage any stickers or labels.
- Ultrasonic cleaning could damage the module permanently.

The best approach is to consider using a “no clean” solder paste and eliminate the post-soldering cleaning step.

Optical Inspection

After soldering the Module to the host board, consider optical inspection to check the following:

- Proper alignment and centering of the module over the pads.
- Proper solder joints on all pads.
- Excessive solder or contacts to neighboring pads, or vias.

Repeating Reflow Soldering

Only a single reflow soldering process is encouraged for host boards.

Wave Soldering

If a wave soldering process is required on the host boards due to the presence of leaded components, only a single wave soldering process is encouraged.

PROCESSING *(Continued)*

Hand Soldering

Hand soldering is possible. When using a soldering iron, follow IPC recommendations (reference document IPC-7711)

Rework

The MeshConnect Module can be unsoldered from the host board. Use of a hot air rework tool should be programmable and the solder joint and module should not exceed the maximum peak reflow temperature of 250 °C.

Caution If temperature ramps exceed the reflow temperature profile, module and component damage may occur due to thermal shock. Avoid overheating.

Warning Never attempt a rework on the module itself, e.g. replacing individual components. Such actions will terminate warranty coverage.

Additional Grounding

Attempts to improve module or system grounding by soldering braids, wires, or cables onto the module RF shield cover is done at the customer's own risk. The numerous ground pins at the module perimeter should be sufficient for optimum immunity to external RF interference.

AGENCY CERTIFICATIONS

FCC Compliance Statement (Part 15.19) Section 7.15 of RSS-GEN

This device complies with Part 15 of the FCC Rules. Operation is subject to the following two conditions:

1. This device may not cause harmful interference.
2. This device must accept any interference received, including interference that may cause undesired operation.

Warning (Part 15.21)

Changes or modifications not expressly approved by CEL could void the user's authority to operate the equipment.

20 cm Separation Distance

To comply with FCC/IC RF exposure limits for general population / uncontrolled exposure, the antenna(s) used for this transmitter must be installed to provide a separation distance of at least 20 cm from all persons and must not be co-located or operating in conjunction with any other antenna or transmitter.

OEM Responsibility to the FCC Rules and Regulations

The MeshConnect Module has been certified per FCC Part 15 rules for integration into products without further testing or certification. To fulfill the FCC certification requirements, the OEM of the MeshConnect Module must ensure that the information provided on the MeshConnect Label is placed on the outside of the final product. The MeshConnect Module is labeled with its own FCC ID Number. If the FCC ID is not visible when the module is installed inside another device, then the outside of the device into which the module is installed must also display a label referring to the enclosed module. This exterior label can use wording such as the following: "Contains Transmitter Module FCC ID: W7Z-ICP0" or "Contains FCC ID: W7Z-ICP0"

The OEM of the MeshConnect Module must only use the approved antenna, (PCB Trace Antenna) that has been certified with this module. The OEM of the MeshConnect Module must test their final product configuration to comply with Unintentional Radiator Limits before declaring FCC compliance per Part 15 of the FCC rules.

AGENCY CERTIFICATIONS *(Continued)*

IC Certification – Industry Canada Statement

The term "IC" before the certification / registration number only signifies that the Industry Canada technical specifications were met.

Certification IC - Déclaration d'Industrie Canada

Le terme "IC" devant le numéro de certification / d'enregistrement signifie seulement que les spécifications techniques Industrie Canada ont été respectées.

Section 14 of RSS-210

The installer of this radio equipment must ensure that the antenna is located or pointed such that it does not emit RF field in excess of Health Canada limits for the general population. Consult Safety Code 6, obtainable from Health Canada's website: <http://www.hc-sc.gc.ca/ewh-semt/pubs/radiation/99ehd-dhm237/index-eng.php>

L'article 14 du CNR-210

Le programme d'installation de cet équipement radio doit s'assurer que l'antenne est située ou orientée de telle sorte qu'il ne pas émettre de champ RF au-delà des limites de Santé Canada pour la population générale. Consulter le Code de sécurité 6, disponible sur le site Web de Santé Canada: <http://www.hc-sc.gc.ca/ewh-semt/pubs/radiation/99ehd-dhm237/index-eng.php>

CE Certification – Europe

The MeshConnect RF module has been tested and certified for use in the European Union.

OEM Responsibility to the European Union Compliance Rules

If the MeshConnect module is to be incorporated into a product, the OEM must verify compliance of the final product to the European Harmonized EMC and Low-Voltage / Safety Standards. A Declaration of Conformity must be issued for each of these standards and kept on file as described in Annex II of the R&TTE Directive.

The manufacturer must maintain the user's guide and adhere to the settings described in the manual for maintaining European Union Compliance. If any of the specifications are exceeded in the final product, the OEM is required to make a submission to the notified body for compliance testing.

OEM Labeling Requirements

The `CE' mark must be placed on the OEM product in a visible location.

The CE mark shall consist of the initials "CE" with the following form:

- If the CE marking is reduced or enlarged, the proportions given in the above graduated drawing must be adhered to.
- The CE mark must be a minimum of 5mm in height
- The CE marking must be affixed visibly, legibly, and indelibly. Since the 2400 - 2483.5 MHz band is not harmonized by a few countries throughout Europe, the Restriction sign must be placed to the right of the "CE" marking as shown in the picture



SHIPMENT, HANDLING, AND STORAGE

Shipment

The MeshConnect Modules are delivered in trays of 28.

Handling

The MeshConnect Modules are designed and packaged to be processed in an automated assembly line.

Warning The MeshConnect Modules contain highly sensitive electronic circuitry. Handling without proper ESD protection may destroy or damage the module permanently.

Warning The MeshConnect Modules are moisture-sensitive devices. Appropriate handling instructions and precautions are summarized in J-STD-033. Read carefully to prevent permanent damage due to moisture intake.

Moisture Sensitivity Level (MSL)

MSL 3, per J-STD-033

Storage

Storage/shelf life in sealed bags is 12 months at <40°C and <90% relative humidity.

REFERENCES & REVISION HISTORY

Previous Versions	Changes to Current Version	Page(s)
0008-00-07-00-000 (Issue ES) October 14, 2010	Initial preliminary datasheet.	N/A
0008-00-07-00-000 (Issue A) January 21, 2011	Updated RF Channels to 15 for FCC Certification. Updated Pin out table. Updated processing guidelines.	1, 5

Disclaimer

- The information in this document is current as of the published date. The information is subject to change without notice. For actual design-in, refer to the latest publications of CEL data sheets or data books, etc., for the most up-to-date specifications of CEL products. Not all products and/or types are available in every country. Please check with an CEL sales representative for availability and additional information.
- No part of this document may be copied or reproduced in any form or by any means without the prior written consent of CEL. CEL assumes no responsibility for any errors that may appear in this document.
- CEL does not assume any liability for infringement of patents, copyrights or other intellectual property rights of third parties by or arising from the use of CEL products listed in this document or any other liability arising from the use of such products. No license, express, implied or otherwise, is granted under any patents, copyrights or other intellectual property rights of CEL or others.
- Descriptions of circuits, software and other related information in this document are provided for illustrative purposes in semiconductor product operation and application examples. The incorporation of these circuits, software and information in the design of a customer's equipment shall be done under the full responsibility of the customer. CEL assumes no responsibility for any losses incurred by customers or third parties arising from the use of these circuits, software and information.
- While CEL endeavors to enhance the quality, reliability and safety of CEL products, customers agree and acknowledge that the possibility of defects thereof cannot be eliminated entirely. To minimize risks of damage to property or injury (including death) to persons arising from defects in CEL products, customers must incorporate sufficient safety measures in their design, such as redundancy, fire-containment and anti-failure features.