

MN4000B/MN4000BS

Dual 3-Input NOR Gates and Inverters

■ Description

The MN4000B/S are dual 3-input NOR gate and inverters. Their primary use is where low power dissipation and/or high noise immunity is desired.

■ Logic Diagram

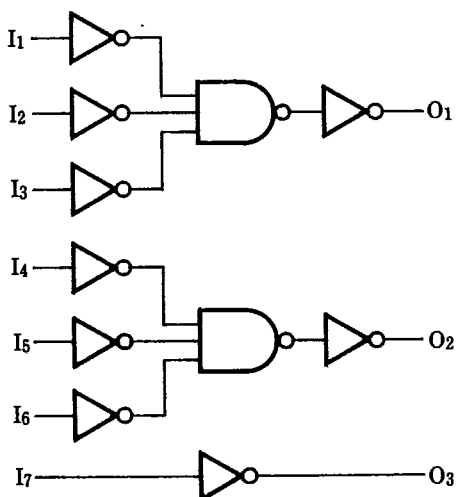

P-1

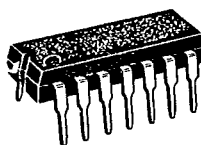

14-Pin • Plastic DIL Package

P-2



14-Pin • Panafiat Package (SO-14D)

Pin Configuration

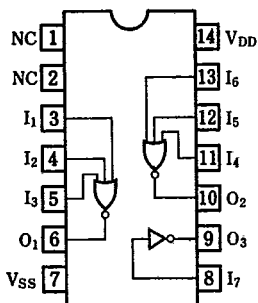

■ Maximum Ratings (Ta=25°C)

Item	Symbol	Ratings	Unit
Supply Voltage	V_{DD}	-0.5~+18	V
Input Voltage	V_i	-0.5~ $V_{DD}+0.5^*$	V
Output Voltage	V_o	-0.5~ $V_{DD}+0.5^*$	V
Peak Input · Output Current	$\pm I_i$	max. 10	mA
Power Dissipation (per package)	$T_a = -40 \sim +60^\circ\text{C}$	max. 400	mW
	$T_a = +60 \sim +85^\circ\text{C}$	Decrease up to 200mW rating at 8mW/°C	
Power Dissipation (per output terminal)	P_D	max. 100	mW
Operating Ambient Temperature	T_{opr}	-40~+85	°C
Storage Temperature	T_{stg}	-65~+150	°C

* $V_{DD} + 0.5V$ should be under 18V

■ DC Characteristics (V_{SS}=0V)

Item	V _{DD} (V)	Symbol	Conditions	Ta=-40°C		Ta=25°C		Ta=85°C		Unit
				min.	max.	min.	max.	min.	max.	
Quiescent Power Supply Current	5	I _{DD}	V _I =V _{SS} or V _{DD}	—	1	—	1	—	7.5	μA
	10			—	2	—	2	—	15	
	15			—	4	—	4	—	30	
Output Voltage Low Level	5	V _{OL}	V _I =V _{SS} or V _{DD} I _{OL} <1μA	—	0.05	—	0.05	—	0.05	V
	10			—	0.05	—	0.05	—	0.05	
	15			—	0.05	—	0.05	—	0.05	
Output Voltage High Level	5	V _{OH}	V _I =V _{SS} or V _{DD} I _{OL} <1μA	4.95	—	4.95	—	4.95	—	V
	10			9.95	—	9.95	—	9.95	—	
	15			14.95	—	14.95	—	14.95	—	
Input Voltage Low Level	5	V _{IL}	I _{OL} <1μA V _O =0.5V or 4.5V	—	1.5	—	1.5	—	1.5	V
	10			—	3	—	3	—	3	
	15			—	4	—	4	—	4	
Input Voltage High Level	5	V _{IH}	I _{OL} <1μA V _O =0.5V or 4.5V	3.5	—	3.5	—	3.5	—	V
	10			7	—	7	—	7	—	
	15			11	—	11	—	11	—	
Output Current Low Level	5	I _{OL}	V _O =0.4V, V _I =0V or 5V	0.52	—	0.44	—	0.36	—	mA
	10			1.3	—	1.1	—	0.9	—	
	15			3.6	—	3	—	2.4	—	
Output Current High Level	5	-I _{OH}	V _O =4.6V, V _I =0V or 5V	0.52	—	0.44	—	0.36	—	mA
	10			1.3	—	1.1	—	0.9	—	
	15			3.6	—	3	—	2.4	—	
Output Current High Level	5	-I _{OH}	V _O =2.5V, V _I =0V or 5V	1.7	—	1.4	—	1.1	—	mA
Input Leakage Current	15	±I _I	V _I =0V or 15V	—	0.3	—	0.3	—	1	μA

■ Switching Characteristics (Ta=25°C, V_{SS}=0V, C_L=50pF)

Item	V _{DD} (V)	Symbol	min.	typ.	max.	Unit
Output Rise Time	5	t _{TLH}	—	60	180	ns
	10		—	30	90	
	15		—	20	60	
Output Fall Time	5	t _{THL}	—	60	180	ns
	10		—	30	90	
	15		—	20	60	
Propagation Delay Time I ₁ ~I ₆ →O ₁ , O ₂	5	t _{PHL}	—	70	210	ns
	10		—	35	105	
	15		—	30	90	
Propagation Delay Time I ₇ →O ₃	5	t _{PHL}	—	45	135	ns
	10		—	25	75	
	15		—	20	60	
Input Capacitance		C _I	—	—	7.5	pF

1. Switching Time Test Circuit

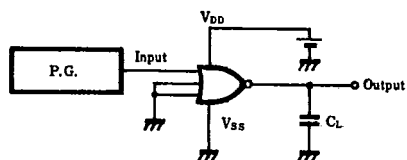

2. Waveforms

