

RF & MICROWAVE TRANSISTORS AVIONICS APPLICATIONS

- DESIGNED FOR HIGH POWER PULSED IFF
- 600 WATTS (min.) IFF 1030 or 1090 MHz
- REFRACTORY GOLD METALLIZATION
- 6.0 dB MIN. GAIN
- LOW THERMAL RESISTANCE FOR RELIABILITY AND RUGGEDNESS
- 30:1 LOAD VSWR CAPABILITY AT SPECIFIED OPERATING CONDITIONS
- INPUT MATCHED, COMMON BASE CONFIGURATION

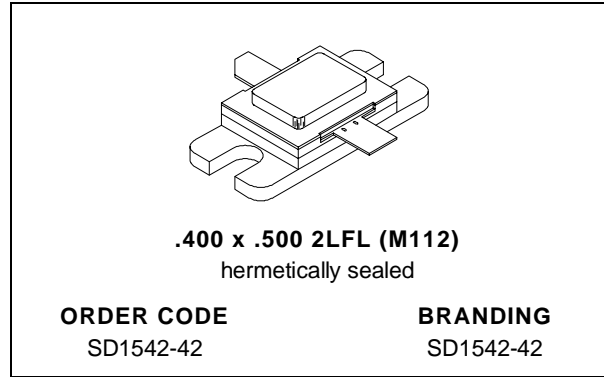

DESCRIPTION

The SD1542-42 is a hermetically sealed, gold metallized, silicon NPN power transistor. The SD1542-42 is designed for applications requiring high peak power and low duty cycles such as IFF. The SD1542-42 is packaged in a hermetic metal/ceramic package with internal input matching, resulting in improved broadband performance and low thermal resistance.

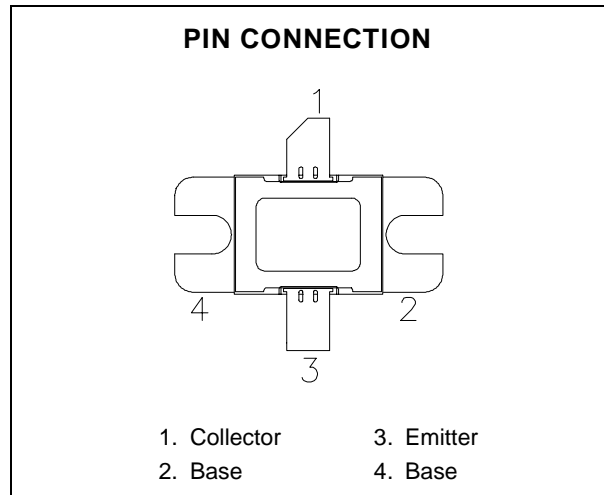

ABSOLUTE MAXIMUM RATINGS (T_{case} = 25°C)

Symbol	Parameter	Value	Unit
V _{CC}	Collector-Supply Voltage*	55	V
I _C	Device Current* (T _C ≤ 100°C)	45	A
P _{DISS}	Power Dissipation*	1670	W
T _J	Junction Temperature	+200	°C
T _{STG}	Storage Temperature	- 65 to +200	°C

THERMAL DATA

R _{TH(j-c)}	Junction-Case Thermal Resistance*	0.06	°C/W
----------------------	-----------------------------------	------	------

* Applies only to rated RF operation.

ELECTRICAL SPECIFICATIONS ($T_{\text{case}} = 25^{\circ}\text{C}$)

STATIC

Symbol	Test Conditions		Value			Unit
			Min.	Typ.	Max.	
BV_{CBO}	$I_{\text{C}} = 25 \text{ mA}$	$I_{\text{E}} = 0 \text{ mA}$	65	—	—	V
BV_{CER}	$I_{\text{C}} = 25 \text{ mA}$	$R_{\text{BE}} = 10 \Omega$	65	—	—	V
BV_{EBO}	$I_{\text{E}} = 10 \text{ mA}$	$I_{\text{C}} = 0 \text{ mA}$	3.5	—	—	V
I_{CES}	$V_{\text{CE}} = 50 \text{ V}$	$V_{\text{BE}} = 0 \text{ V}$	—	—	60	mA
h_{FE}	$V_{\text{CE}} = 5 \text{ V}$	$I_{\text{C}} = 2 \text{ A}$	10	—	250	—

DYNAMIC

Symbol	Test Conditions			Value			Unit
				Min.	Typ.	Max.	
P_{OUT}	$f = 1090 \text{ MHz}$	$P_{\text{IN}} = 150 \text{ W}$	$V_{\text{CC}} = 50 \text{ V}$	600	680	—	W
η_{C}	$f = 1090 \text{ MHz}$	$P_{\text{IN}} = 150 \text{ W}$	$V_{\text{CC}} = 50 \text{ V}$	35	40	—	%
G_{P}	$f = 1090 \text{ MHz}$	$P_{\text{IN}} = 150 \text{ W}$	$V_{\text{CC}} = 50 \text{ V}$	6.0	6.6	—	dB

Note: Pulse Width = 10 μ Sec, Duty Cycle = 1%

TYPICAL PERFORMANCE

POWER OUTPUT vs POWER INPUT

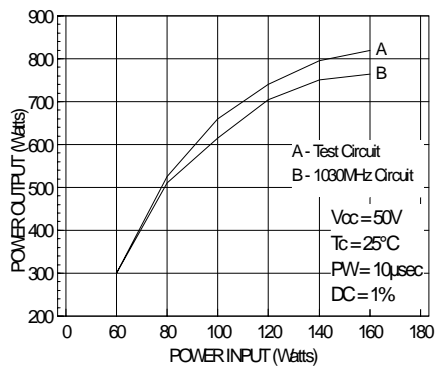

POWER OUTPUT vs FREQUENCY

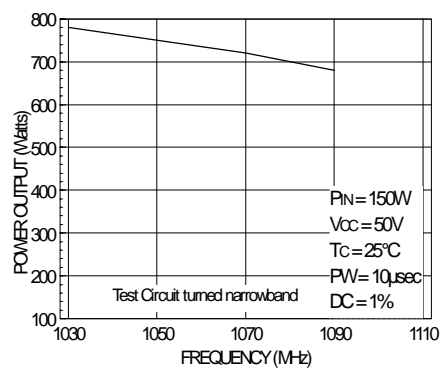

TEST CIRCUIT (1090 MHz)

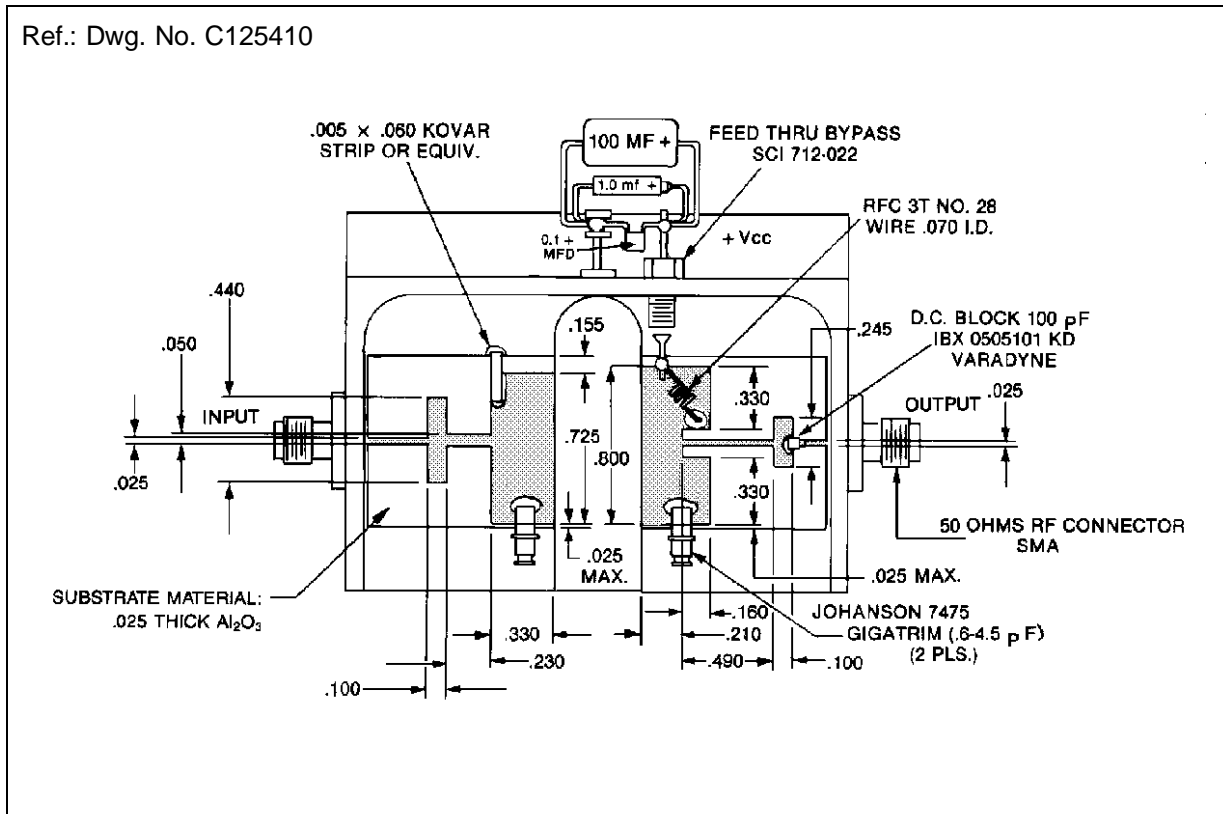

1030 MHz TYPICAL CIRCUIT

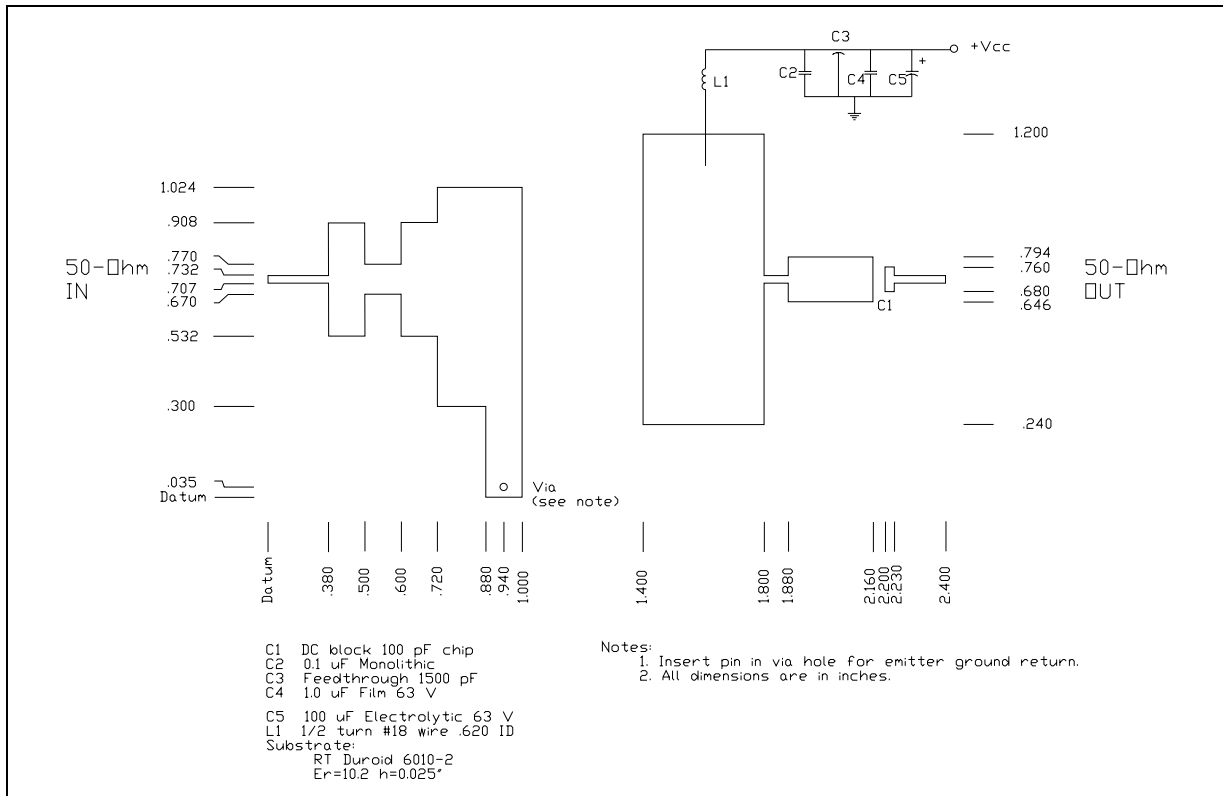

PACKAGE MECHANICAL DATA

Ref.: Dwg. No.12-0112 rev. G

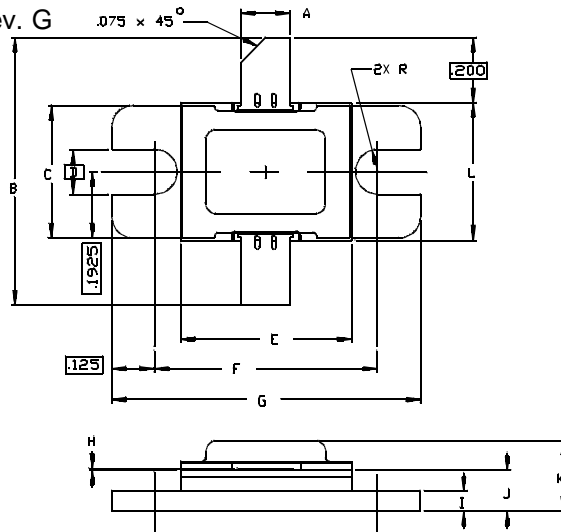

SGS-THOMSON MICROELECTRONICS		
	MINIMUM Inches/mm	MAXIMUM Inches/mm
A	.145/3.68	.155/3.93
B	.750/19.05	
C	.380/9.65	.390/9.91
D	.130/3.30	
E	.495/12.57	.507/12.88
F	.640/16.26	.655/16.64
G	.890/22.61	.910/23.11
H	.002/0.05	.006/0.15
I	.055/1.40	.065/1.65
J	.115/2.92	.135/3.43
K		.230/5.84
L	.395/10.03	.407/10.34

Information furnished is believed to be accurate and reliable. However, SGS-THOMSON Microelectronics assumes no responsibility for the consequences of use of such information nor for any infringement of patents or other rights of third parties which may result from its use. No license is granted by implication or otherwise under any patent or patent rights of SGS-THOMSON Microelectronics. Specifications mentioned in this publication are subject to change without notice. This publication supersedes and replaces all information previously supplied. SGS-THOMSON Microelectronics products are not authorized for use as critical components in life support devices or systems without express written approval of SGS-THOMSON Microelectronics.

©1995 SGS-THOMSON Microelectronics - All Rights Reserved

SGS-THOMSON Microelectronics GROUP OF COMPANIES

Australia - Brazil - France - Germany - Hong Kong - Italy - Japan - Korea - Malaysia - Malta - Morocco - The Netherlands - Singapore - Spain - Sweden - Switzerland - Taiwan - Thailand - United Kingdom - U.S.A.