

UTC 2SD1616/A NPN EPITAXIAL SILICON TRANSISTOR

NPN EPITAXIAL SILICON TRANSISTOR

DESCRIPTION

- *Audio frequency power amplifier
- *Medium speed switching

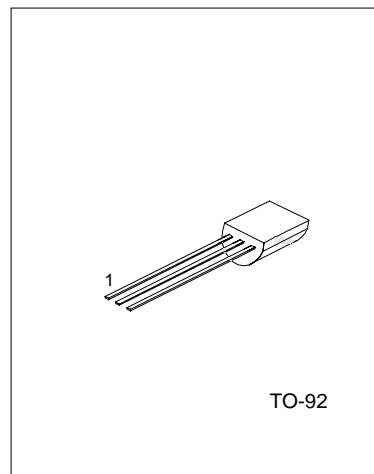

1: EMITTER 2: COLLECTOR 3: BASE

ABSOLUTE MAXIMUM RATINGS

PARAMETER	SYMBOL	VALUE	UNIT
Storage Temperature	Tstg	-55 ~+150	°C
Junction Temperature	Tj	150	°C
Total Power Dissipation (Ta=25°C)	Pc	750	mW
Collector to Base Voltage: D1616	VCBO	60	V
D1616A		120	
Collector to Emitter Voltage: D1616	VCEO	50	V
D1616A		60	
Emitter to Base Voltage	VEBO	6	V
Collector Current (DC)	Ic	1	A
Collector Current (*Pulse)	Ic	2	A

Note: (*) Pulse width≤10ms, Duty cycle<50%

CHARACTERISTICS (Ta=25°C)

CHARACTERISTIC	SYMBOL	TEST CONDITIONS	MIN.	TYP.	MAX.	UNIT
Collector Cut-Off Current	ICBO	VCB=60V			100	nA
Emitter Cut-Off Current	IEBO	VEB= 6V			100	nA
Collector-Emitter Saturation Voltage	VCE(SAT)	IC=1A, IB=50mA		0.15	0.3	V
Base-Emitter Saturation Voltage	VBE(SAT)	IC=1A, IB=50mA		0.9	1.2	V
Base Emitter On Voltage	VBE(ON)	VCE=2V, IC=50mA	600	640	700	mV
DC Current Gain: D1616	hFE1	VCE=2V, IC=100mA	135		600	
			D1616A	135		400
	hFE2	VCE=2V, IC=1A	81			
Current Gain Bandwidth Product	fT	VCE=2V, IC=100mA	100	160		MHz
Output Capacitance	Cob	VCB=10V, f=1MHz			19	pF
Turn On Time	ton	VCE=10V, IC=100mA		0.07		us

UTC UNISONIC TECHNOLOGIES CO., LTD. 1

QW-R201-008,A

UTC 2SD1616/A NPN EPITAXIAL SILICON TRANSISTOR

CHARACTERISTIC	SYMBOL	TEST CONDITIONS	MIN.	TYP.	MAX.	UNIT
Storage Time	t_s	$I_{B1} = -I_{B2} = 10\text{mA}$		0.95		μs
Fall Time	t_f	$V_{BE}(\text{off}) = -2 \sim -3\text{V}$		0.07		μs

Classification of h_{FE1}

RANK	Y	G	L
h_{FE1}	135-270	200-400	300-600

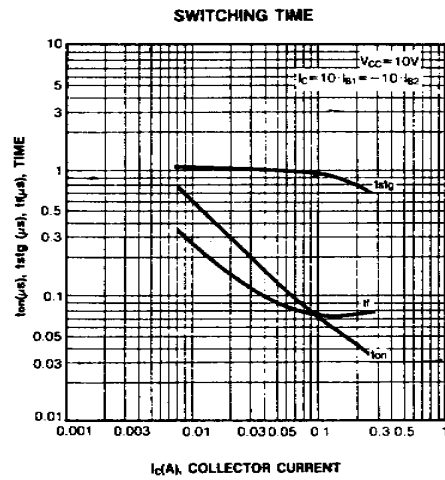
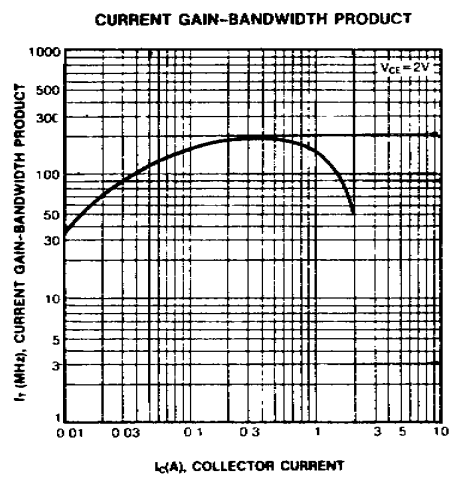
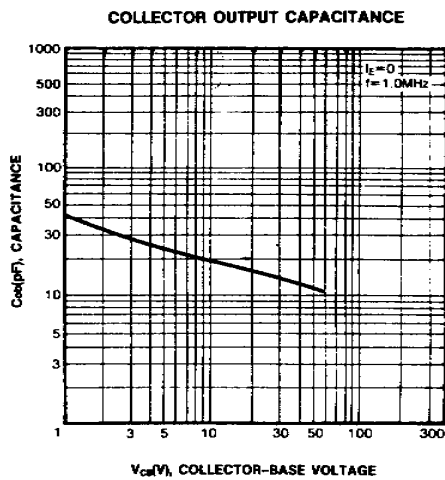

UTC UNISONIC TECHNOLOGIES CO., LTD. 2

QW-R201-008,A

UTC 2SD1616/A NPN EPITAXIAL SILICON TRANSISTOR

