

Ultra Low Power 3-Pin Power-On Reset IC

Description

The V6300 and V6301 are CMOS devices which monitor the supply voltage of any electronic system, and generate the appropriate Reset signal. The threshold defines the minimum allowed voltage which guarantees the good functionality of the system. As long as V_{DD} stays upside this voltage level, the output stays inactive. If V_{DD} drops below V_{TH} , the output gets active. When V_{DD} rises above V_{TH} , the output remains active for an additional 290 ms (V6301) or 50 ms (V6300). This allows the system to stabilize before getting fully active. The threshold voltage may be obtained in different versions: 2.0V, 2.4V, 2.8V, 3.5V, 4.0V, 4.5V.

Applications

All microprocessor applications where an automatic restart is required:

- Computer electronics
- White / Brown goods
- Automotive electronics
- Industrial electronics
- Telecom systems
- Hand-held systems

Features

- Clear microprocessor restart after power up
- Processor reset at power down
- Reset output guaranteed down to $V_{DD} = 1V$
- Low power consumption: typ. $3\mu A$ at $V_{DD} = 5V$
- -40 to $+85^{\circ}C$ temperature range
- Power-on reset time:
 - V6300: 50 ms (typ)
 - V6301: 290 ms (typ)
- On-chip oscillator
- No external components required
- Push-pull or open drain active low Reset output
- SOT-23 5L package

Typical Operating Configuration

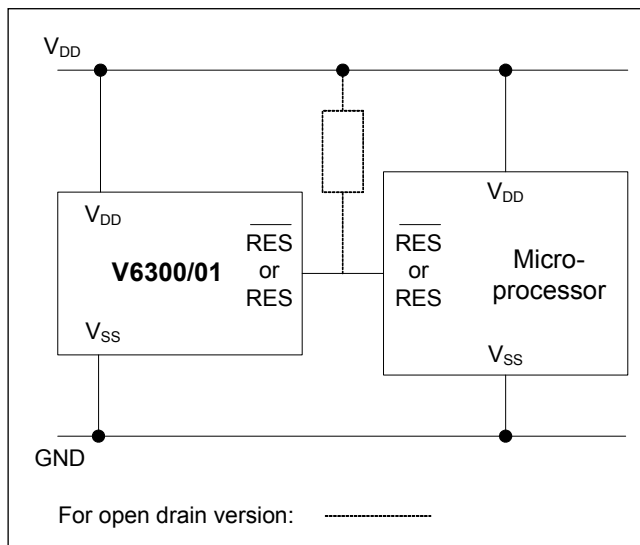

Fig. 1

Pin Assignment

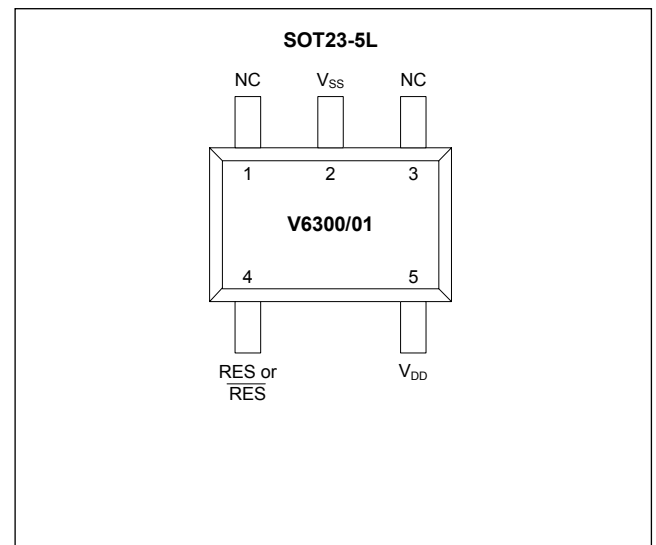

Fig. 2

Absolute Maximum Ratings

Parameter	Symbol	Conditions
Voltage at V_{DD} to V_{SS}	V_{DD}	-0.3V to +10V
Minimum voltage at RES or \overline{RES}	V_{min}	$V_{SS} - 0.3V$
Maximum voltage at RES or \overline{RES}	V_{max}	$V_{DD} + 0.3V$
Storage Temperature Range	T_{STO}	-65°C to +150°C

Table 1

Stresses above these listed maximum ratings may cause permanent damages to the device. Exposure beyond specified operating conditions may affect device reliability or cause malfunction.

Handling Procedures

This device has built-in protection against high static voltages or electric fields; however, it is advised that normal precautions be taken as for any other CMOS component. Unless otherwise specified, proper operation can only occur when all terminal voltages are kept within the voltage range.

Operating Conditions

Parameter	Symbol	Min	Max	Unit
Operating Temperature ¹⁾	T_A	-40	+125	°C
Positive Supply Voltage	V_{DD}	1	8	V

Table 2

¹⁾The maximum operating temperature is confirmed by sampling at initial device qualification.

Electrical Characteristics

$T_A = -40$ to $+85^\circ\text{C}$, unless otherwise specified

Parameter	Symbol	Test Conditions	Min.	Min @ 25°C	Typ.	Max. @ 25°C	Max.	Unit
Supply current ¹⁾	I_{DD}	$V_{DD} = 2V$ ³⁾			1.5	2.1	3.1	μA
		$V_{DD} = 5V$			3.0	3.9	5.7	μA
		$V_{DD} = 8V$			5.2	6.8	10.0	μA
Threshold voltage	V_{TH}	Version: A,G,M	1.77	1.84	1.95	2.04	2.17	V
		Version: B,H,N	2.09	2.18	2.32	2.41	2.55	V
		Version: C,I,O	2.48	2.59	2.73	2.86	3.03	V
		Version: D,J,P	3.11	3.23	3.42	3.59	3.80	V
		Version: E,K,Q	3.55	3.70	3.88	4.08	4.32	V
Version: F,L,R	4.05	4.22	4.42	4.67	4.95	V		
Threshold hysteresis	V_{HYS}			25			mV	
RES Output Low Level	V_{OL}	$V_{DD} = 5V, I_{OL} = 8\text{mA}$			175		400	mV
		$V_{DD} = 3V, I_{OL} = 4\text{mA}$			140		300	mV
		$V_{DD} = 1V, I_{OL} = 50\mu\text{A}$			20		90	mV
RES Output High Level	V_{OH}	$V_{DD} = 5V, I_{OH} = -8\text{mA}$	4.3		4.5			V
		$V_{DD} = 3V, I_{OH} = -4\text{mA}$	2.3		2.6			V
		$V_{DD} = 1V, I_{OH} = -100\mu\text{A}$	850		950			mV
Output leakage current ²⁾	I_{LEAK}	$V_{DD} = 8V$			0.05		1	μA

Table 3

- 1) RES or \overline{RES} open
- 2) Only for Open drain versions
- 3) Versions A, G and M are tested at $V_{DD} = 1.8V$

Timing Characteristics

$V_{DD} = 5.0V$, $T_A = -40$ to $+85^\circ\text{C}$, unless otherwise specified

Parameter	Symbol	Test Conditions	Min.	Typ.	Max.	Units
Power on reset time:	t_{POR}	V6300	25	50	75	ms
		V6301	140	290	560	ms
Sensitivity ⁴⁾	t_{SEN}	for $V_{DD} = 5V$ to $3V$ in $5\mu\text{s}$	20	$0.8 t_R$		μs
Reaction time ⁴⁾	t_R	for $V_{DD} = 5V$ to $3V$ in $5\mu\text{s}$	22	75	150	μs

Table 4

- 4) Tested on versions with V_{TH} higher than $3V$

Timing Waveforms

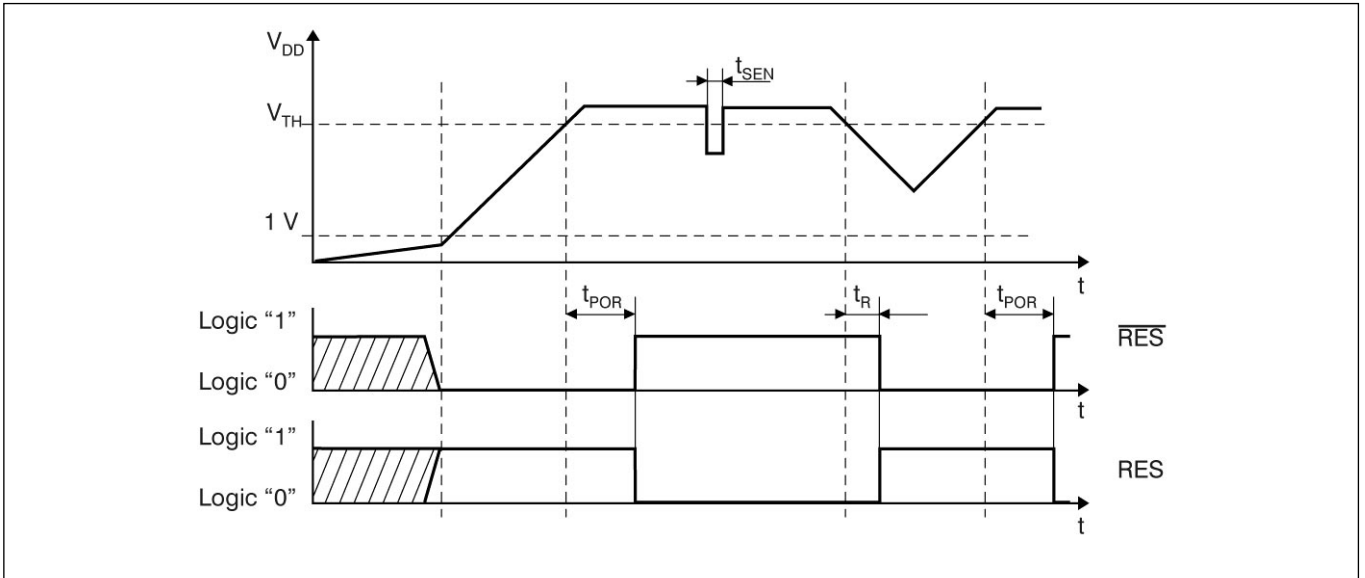

Fig. 3

Block Diagram

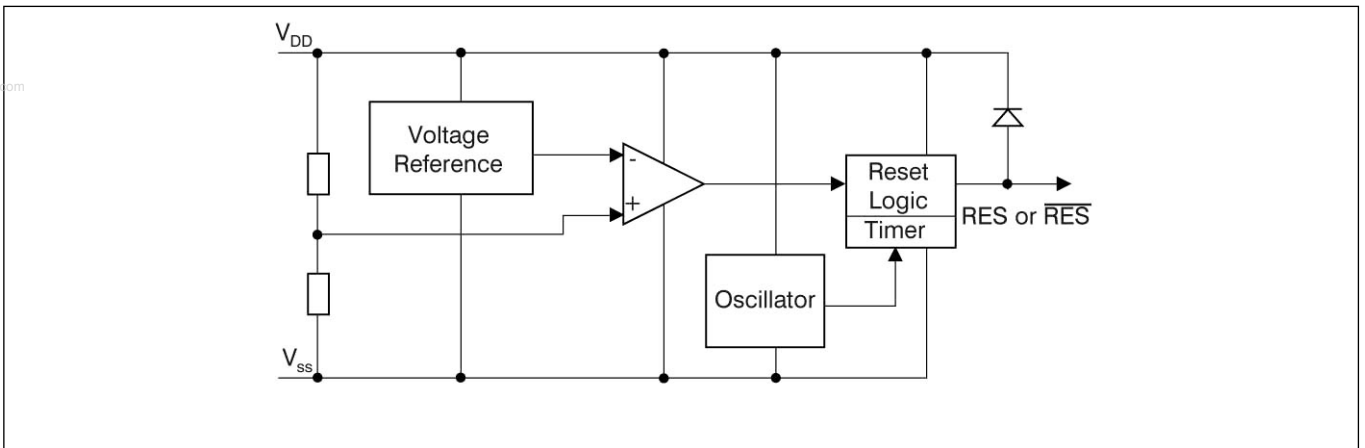

Fig. 4

Pin Description

TO-92

Pin	Name	Function
1	V _{DD}	Positive supply
2	RES or RES	Reset output
3	V _{SS}	Supply ground

Table 5

SOT23-5L

Pin	Name	Function
1	NC	No connection
2	V _{SS}	Supply ground
3	NC	No connection
4	RES or RES	Reset output
5	V _{DD}	Positive supply

Table 6

Pin Assignment

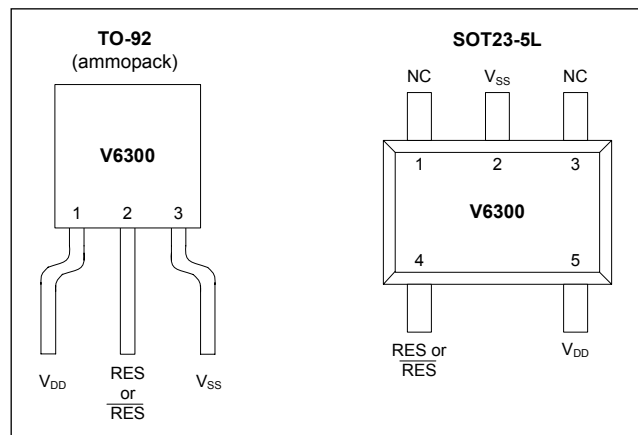

Fig. 7

Packaging and Ordering Information

Dimensions of SOT23-5L Package

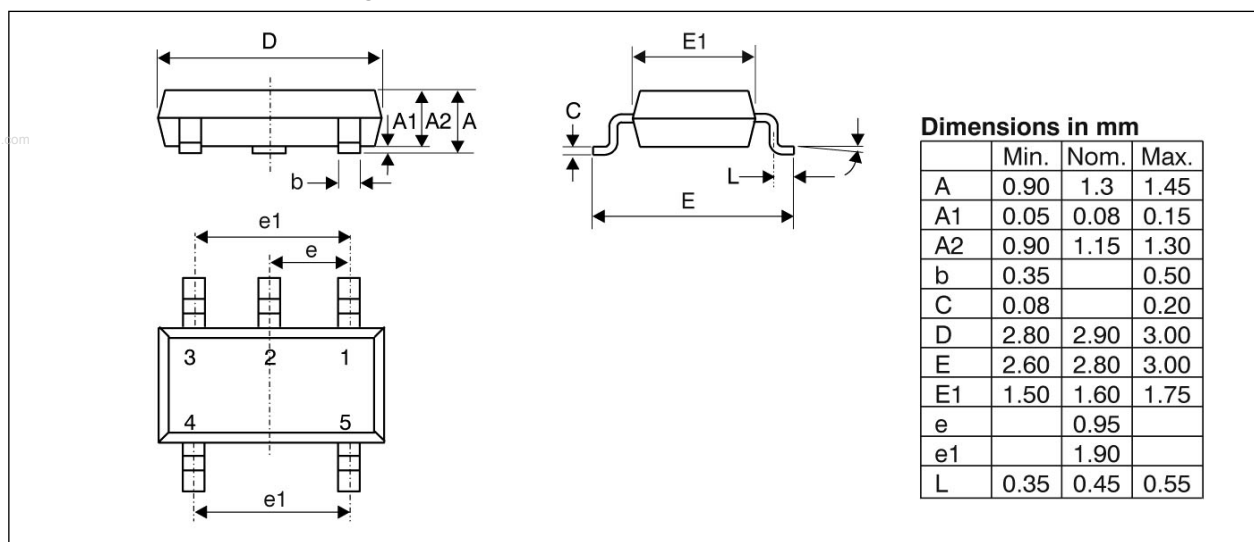

Fig. 5

Dimensions of TO-92 Package (ammopack)

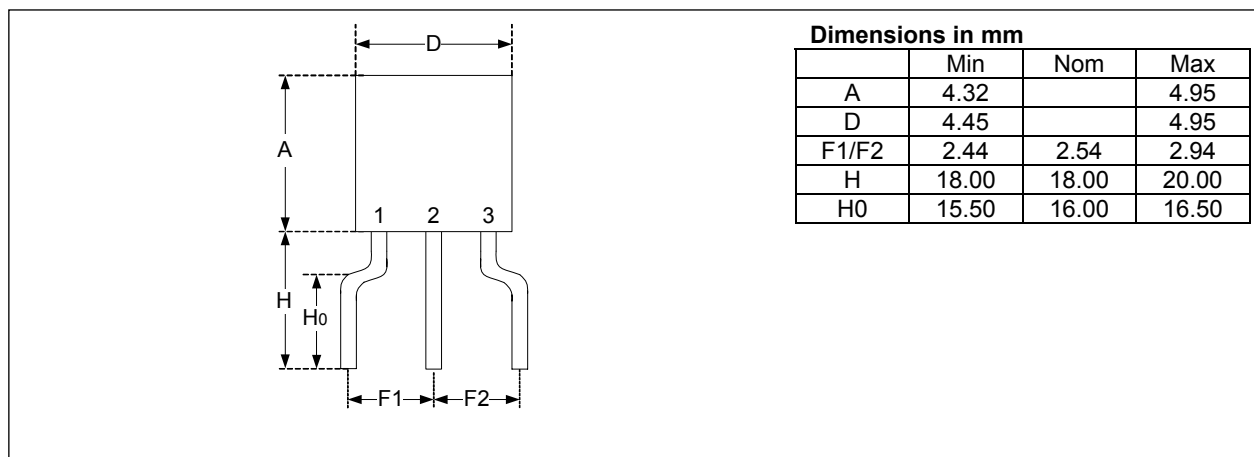

Fig. 6



Ordering Information

Part Number: V6300 F SP5B +

Part Root

V6300: $t_{POR} = 50$ ms (typ)

V6301: $t_{POR} = 290$ ms (typ)

Threshold Voltage and Output Type

	2.0V	2.4V	2.8V	3.5V	4.0V	4.5V
Push-pull, Reset active low	A	B	C	D	E	F
Push-pull, Reset active high	G	H	I	J	K	L
Open drain, Reset active low	M	N	O	P	Q	R

Table 7

RoHS

+ = lead-free & green mold

[blank] = leaded

Package and Delivery Form

SP5B = SOT23-5, Tape & Reel, 3000 pcs

TO3E = TO92, Ammopack (**not for new design**)

Subject to minimum order quantity and availability. Please contact EM Microelectronic for availability.

When ordering, please specify the complete Part Number without space between letters: eg. V6300FSP5B, V6301RSP5B, etc.

Package Marking for SOT23-5L

Part Number	Top Marking ³⁾	Top Marking with 4 Characters ¹⁾	Top Marking with 3 Characters ²⁾
V6300ASP5B		ABAA	BA#
V6300ASP5B+	E0##	BBAA	
V6300BSP5B		ABAB	BB#
V6300CSP5B	PB##	ABAC	BC#
V6300CSP5B+	E7##	BBAC	
V6300DSP5B		ABAD	BD#
V6300ESP5B	PA##	ABAE	BE#
V6300ESP5B+	E4##	BBAE	
V6300FSP5B	P8##	ABAF	BF#
V6300FSP5B+	E2##	BBAF	
V6300GSP5B		ABAG	BG#
V6300HSP5B		ABAH	BH#
V6300ISP5B		ABAI	BI#
V6300JSP5B		ABAJ	BJ#
V6300KSP5B		ABAK	BK#
V6300LSP5B		ABAL	BL#
V6300LSP5B+	EM#	BBAL	
V6300MSP5B		ABAM	BM#
V6300NSP5B		ABAN	BN#
V6300OSP5B		ABAO	BO#
V6300OSP5B+	EE##	BBAL	
V6300PSP5B		ABAP	BP#
V6300QSP5B		ABAQ	BQ#
V6300OSP5B		ABAR	BR#
V6300RSP5B+	EH##	BBAR	

Part Number	Top Marking ³⁾	Top Marking with 4 characters ¹⁾	Top Marking with 3 characters ²⁾
V6301ASP5B		ACAA	CA#
V6301ASP5B+	EN##	BCAA	
V6301BSP5B		ACAB	CB#
V6301CSP5B		ACAC	CC#
V6301DSP5B		ACAD	CD#
V6301ESP5B		ACAE	CE#
V6301FSP5B		ACAF	CF#
V6301FSP5B+	EP##	BCAF	
V6301GSP5B		ACAG	CG#
V6301HSP5B		ACAH	CH#
V6301ISP5B		ACAI	CI#
V6301JSP5B		ACAJ	CJ#
V6301KSP5B		ACAK	CK#
V6301LSP5B		ACAL	CL#
V6301MSP5B		ACAM	CM#
V6301NSP5B		ACAN	CN#
V6301OSP5B		ACAO	CO#
V6301OSP5B+	EL##	BCAO	
V6301PSP5B		ACAP	CP#
V6301QSP5B		ACAQ	CQ#
V6301RSP5B		ACAR	CR#

Table 9

- Top marking with 4 characters is standard from 2003. For lead-free/green mold (RoHS) parts, the first letter of top marking with 4 characters begins with letter "B" instead of letter "A". Bottom marking indicates the lot number.
- Top marking with 3 characters is kept as information since it was used until 2002. Where # refers to the lot number (EM internal reference only)
- Top marking is the standard from 2006. No bottom marking exists. Where ## refers to the lot number (EM internal reference only)

Traceability for small packages

Due to the limited space on the package surface, the bottom marking contains a limited number of characters that provide only partial information for lot traceability. Full information for complete traceability is however provided on the packing labels of the product at delivery from EM: It is highly recommended that the customer insures full lot traceability of EM product in his final product.



V6300

V6301

Package Marking for TO-92

Part Number	Top Marking
V6300%TO3E	V6300%

Table 8

where % refers to the letter for the threshold voltage in Table 7 (B, C, D, etc).

EM Microelectronic-Marin SA (EM) makes no warranty for the use of its products, other than those expressly contained in the Company's standard warranty which is detailed in EM's General Terms of Sale located on the Company's web site. EM assumes no responsibility for any errors which may appear in this document, reserves the right to change devices or specifications detailed herein at any time without notice, and does not make any commitment to update the information contained herein. No licenses to patents or other intellectual property of EM are granted in connection with the sale of EM products, expressly or by implications. EM's products are not authorized for use as components in life support devices or systems.

© EM Microelectronic-Marin SA, 02/06, Rev.L