

HWP-2P, 3P Series / Wire Wrap Terminal for SMT

- Can be mounted by Auto Insertion System
- Can be used as terminal for Jumper (JS-1)
- Can be attached by reflow
- Can select 3p or 2p type
- Operating Temperature.....-40~+125°C
- Material: Pin part: Brass Plastic part: PPSblack (UL94V-0)
- Current Capacity: 3A
- Insulation Resistance: 500MΩ and over
- Withstand Voltage: 1000V AC, DC 1min
- Finish: -G Plated Au over Ni
-S Plated Sn over Ni

N/O	Package
HWP-2P-G	100pcs/bulk
HWP-2P-G-M	100pcs/cartridge
HWP-2P-G-T	1200pcs/reel
HWP-2P-S	100pcs/bulk
HWP-2P-S-M	100pcs/cartridge
HWP-2P-S-T	1200pcs/reel
HWP-3P-G	100pcs/bulk
HWP-3P-G-M	70pcs/cartridge
HWP-3P-G-T	1200pcs/reel
HWP-3P-S	100pcs/bulk
HWP-3P-S-M	70pcs/cartridge
HWP-3P-S-T	1200pcs/reel

Recommended Land Diameter

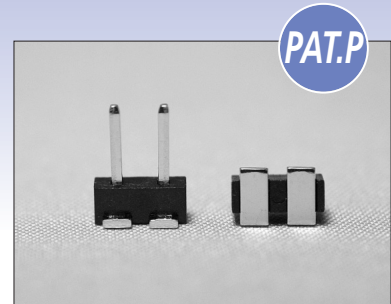
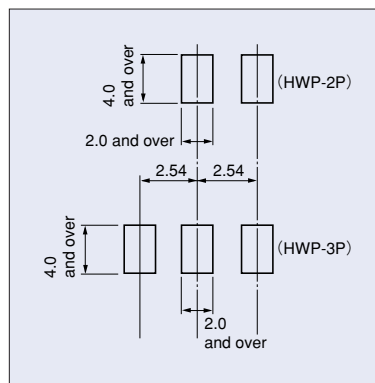

HWP-2P

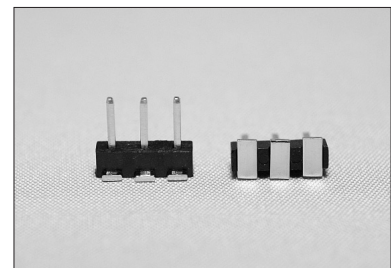
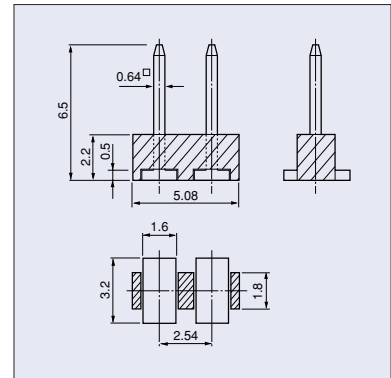

HWP-3P

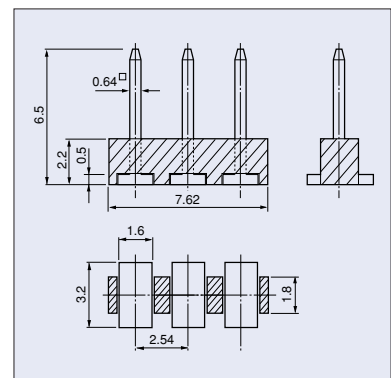

Jumper Socket for HWP Series [JS-1]

Material
 Contact Part: Phosphor Bronze
 Plastic Part: PBT Black (UL94V-0)
 Finish
 Contact Part: Plated Au over Ni
 Current Capacity: 3A
 Rated Voltage: 250V AC, DC
 Contact Resistance: 20mΩ and below
 Adaptive Pin Diameter.....0.64□
 Capacity of Insertion and Removal: 70g and over
 Operating Temperature.....-40~+125°C

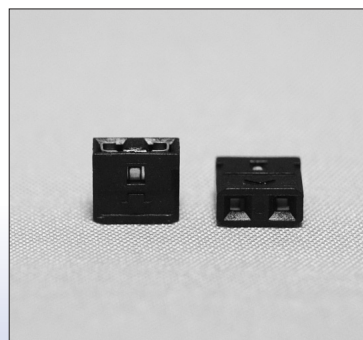
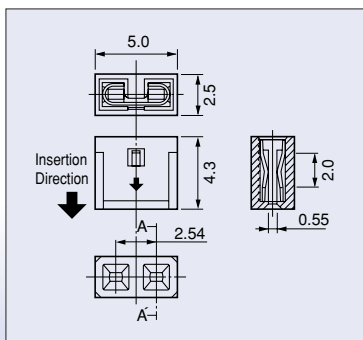

MAC8

No.1 distributor of MAC8

SHINDENKIZAI Co., LTD.

Contact
 e-mail: sdk@mac8sdk.co.jp FAX: +81-3-3253-5965

http://www.mac8sdk.co.jp/index_e.html

MJP, MJ Series / Jumper Wire for SMT

Jumper Wire for SMT [MJP Series]

PAT

- Can be mounted by Auto Insertion System
- The distance between MJP and PCB is 1.8mm
- Can be attached by reflow
- Material: Phosphor Bronze (Bronze only for MJP-0.1)
- Finish: Sn plated over Ni base
- Current Rating: 20A

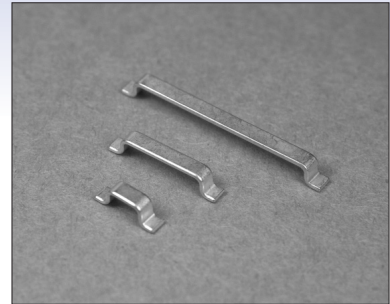

N/O	A	B	Package
MJP-0.2	3.08	6.48	1000/pack
MJP-0.2-T	3.08	6.48	1500/reel
MJP-0.3	5.62	9.02	1000/pack
MJP-0.3-T	5.62	9.02	1500/reel
MJP-0.4	8.16	11.56	1000/pack
MJP-0.4-T	8.16	11.56	1500/reel
MJP-0.5	10.7	14.1	1000/pack
MJP-0.5-T	10.7	14.1	1500/reel
MJP-0.6	13.24	16.64	1000/pack
MJP-0.6-T	13.24	16.64	1500/reel
MJP-0.7	15.78	19.18	1000/pack
MJP-0.7-T	15.78	19.18	700/reel
MJP-0.8	18.32	21.72	1000/pack
MJP-0.8-T	18.32	21.72	700/reel
MJP-1.0	23.4	26.8	1000/pack
MJP-1.0-T	23.4	26.8	700/reel

Recommended Land Diameter

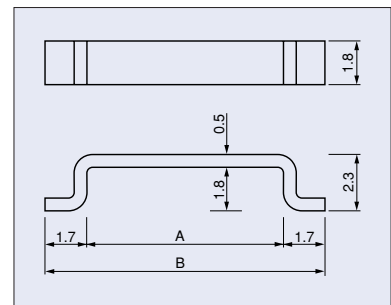
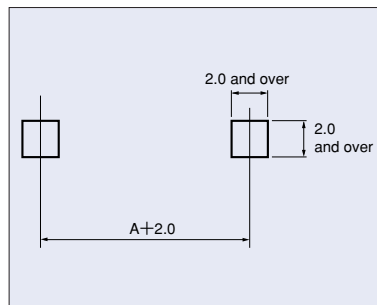

Jumper Wire for SMT [MJ Series]

PAT

- Can be mounted by Auto Insertion System
- The distance between MJ and PCB is 0.5mm
- Can be attached by reflow
- Material: Phosphor Bronze
- Finish: Sn plated over Ni base
- Current Capacity: 7A

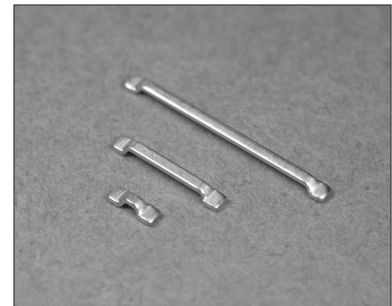

N/O	L (mm)	Package
MJ-0.1	3.54	1000/bulk
MJ-0.1-T	3.54	2000/reel
MJ-0.2	6.08	1000/bulk
MJ-0.2-T	6.08	2000/reel
MJ-0.3	8.62	1000/bulk
MJ-0.3-T	8.62	2000/reel
MJ-0.4	11.16	1000/bulk
MJ-0.4-T	11.16	2000/reel
MJ-0.5	13.7	1000/bulk
MJ-0.5-T	13.7	2000/reel
MJ-0.6	16.24	1000/bulk
MJ-0.6-T	16.24	2000/reel
MJ-0.7	18.78	1000/bulk
MJ-0.8	21.32	1000/bulk

Recommended Land Diameter

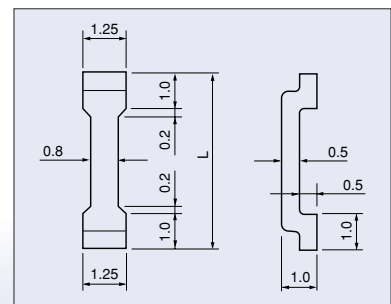
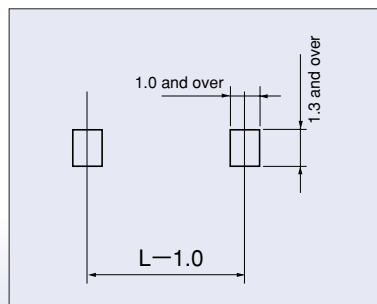

MAC8

No. 1 distributor of MAC8

SHINDENKIZAI Co., LTD.

Contact

e-mail: sdk@mac8sdk.co.jp FAX: +81-3-3253-5965

http://www.mac8sdk.co.jp/index_e.html