

BIPOLAR ANALOG INTEGRATED CIRCUIT

μ PC1406HA

DUAL ATTENUATOR

DESCRIPTION

The μ PC1406HA is a silicon monolithic integrated circuit for sound control (e.g. Volume, Balance). This IC has a good characteristic control curve ('A' Curve), and is very suitable for remote control applications. The two attenuators are completely separate, and it is easy to control the balance between the two attenuators. This IC is manufactured in a 9 Pin slim SIP.

FEATURES

- Each attenuator is completely separate, and is very easy to control with remote control. (e.g. Volume, Balance)
- This IC's characteristic control curve is linear against logarithmic output, and offers smooth control.
- Channel Separation : 64 dB MIN.
- Typical Application : Sound MPX attenuator for TV, Radio and mobile receiver.

BLOCK DIAGRAM

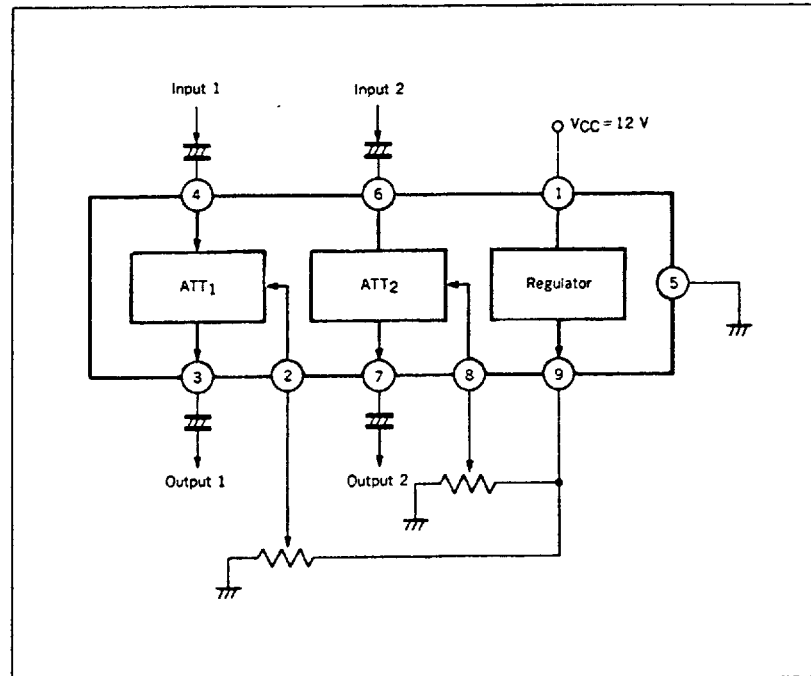

ABSOLUTE MAXIMUM RATINGS (T_a = 25 °C)

Supply Voltage	V _{CC}	0 (MIN.), 15 (MAX.)	V
Signal Input Voltage at pins 4 and 6	V _{in}	3	V _{p-p}
Control Input Voltage at pins 2 and 8	V _{cont}	0 (MIN.), 15 (MAX.)	V
Power Dissipation	P _D	350 (T _a = 75 °C)	mW
Operating Temperature	T _{opt}	-20 to +75	°C
Storage Temperature	T _{stg}	-40 to +125	°C

ELECTRICAL CHARACTERISTICS (V_{CC} = 12 V, T_a = 25 °C, f = 1 kHz)

CHARACTERISTIC	SYMBOL	MIN.	TYP.	MAX.	UNIT	TEST CONDITIONS
Supply Voltage	V _{CC}	8.0	12.0	14.4	V	
Supply Current	I _{CC}	6.0	8.5	13.5	mA	NO SIGNAL
Relative Output	A _v	-2	0	+2	dB	V _{cont} = 1 V, V _{in} = 500 mV _{r.m.s.}
Channel Separation	Sep	64.0	70.0	-	dB	V _{cont} = 5 V, V _{in} = 500 mV _{r.m.s.}
Total Harmonic Distortion	THD	-	0.5	1.0	%	V _{cont} = 5 V, V _{in} = 500 mV _{r.m.s.}
Power Source Noise Rejection	R.R.	30	-	-	dB	H _{um} f = 60 Hz, H _{um} Level = 1 V _{p-p}
Output Voltage 1	ATT ₁	-1.5	0	+1	dB	V _{cont} = 5 V, V _{in} = 500 mV _{r.m.s.}
Output Voltage 2	ATT ₂	-34	-30	-26	dB	V _{cont} = 5 V, V _{in} = 500 mV _{r.m.s.}
Output Voltage 3	ATT ₃	-	-77	-71	dB	V _{cont} = 5 V, V _{in} = 500 mV _{r.m.s.}
Input Resistance	R _i	12	-	24	kΩ	f = 1 kHz
Output Resistance	R _o	200	-	450	Ω	f = 1 kHz

CONNECTION DIAGRAM

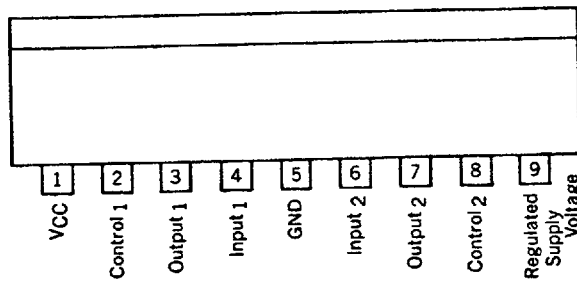

TEST CIRCUIT

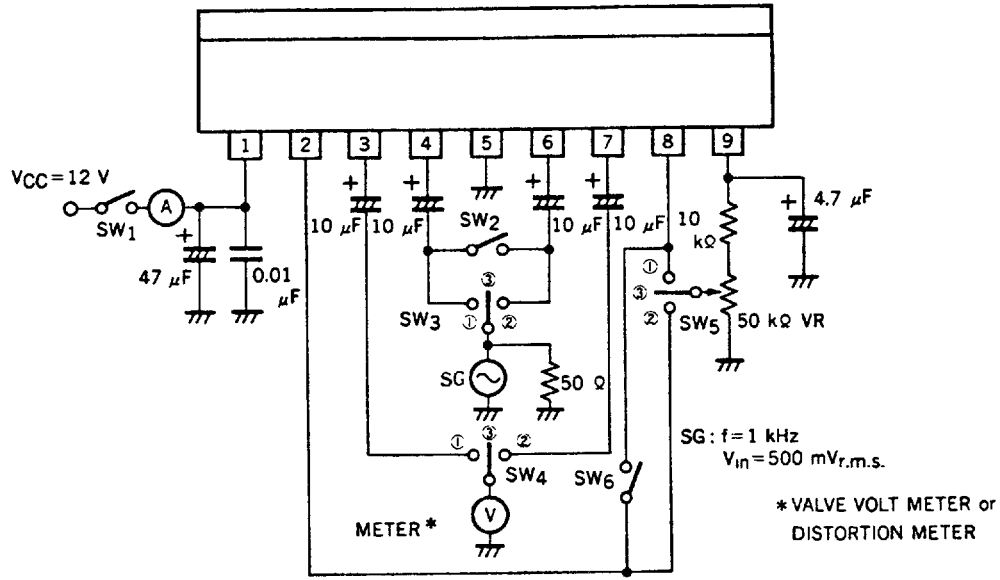
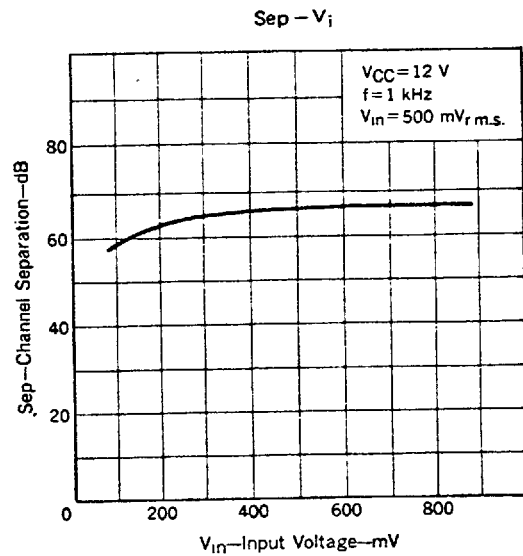
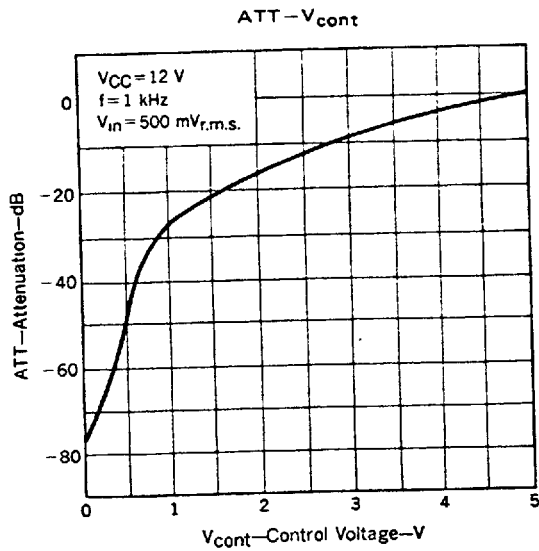
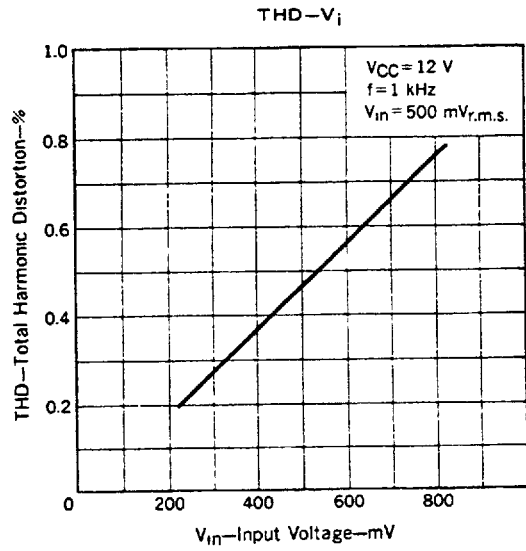
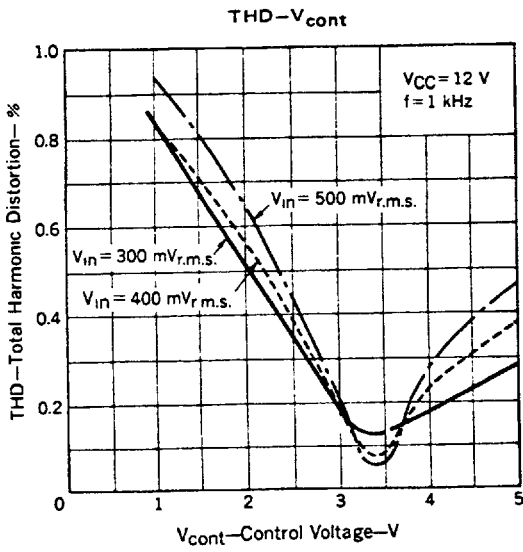

TABLE OF SWITCH CONDITIONS IN THE TEST CIRCUIT

CHARACTERISTIC		SWITCH CONDITION						
		SW ₁	SW ₂	SW ₃	SW ₄	SW ₅	SW ₆	VR
Supply Voltage		ON	ON	•	•	•	ON	5 V
Supply Current		ON	OFF	3	3	•	ON	0 V
Relative Output		ON	ON	•	1 (ch1) 2 (ch2)	•	ON	1 V
Channel Separation	ch1 → ch2	ON	OFF	1	1	2	OFF	5 V
	ch2 → ch1	ON	OFF	2	2	1	OFF	5 V
Distortion Ratio		ON	ON	•	1 (ch1) 2 (ch2)	•	OFF	5 V
Power Source Noise Rejection		ON	•	3	1 (ch1) 2 (ch2)	•	ON	5 V
Output Voltage		ON	ON	•	1 (ch1) 2 (ch2)	•	ON	5 V
Output Voltage 2		ON	ON	•	1 (ch1) 2 (ch2)	•	ON	1 V
Output Voltage 3		ON	ON	•	1 (ch1) 2 (ch2)	•	ON	0 V
Input Resistance		ON	•	•	•	•	•	5 V
Output Resistance		ON	•	•	•	•	•	5 V

* ON, OFF, 1, 2 as convenient

TYPICAL CHARACTERISTICS (T_a = 25 °C)



EXTERNAL COMPONENTS FOR μ PC1406HA

(1) To Control Each Attenuator Separately

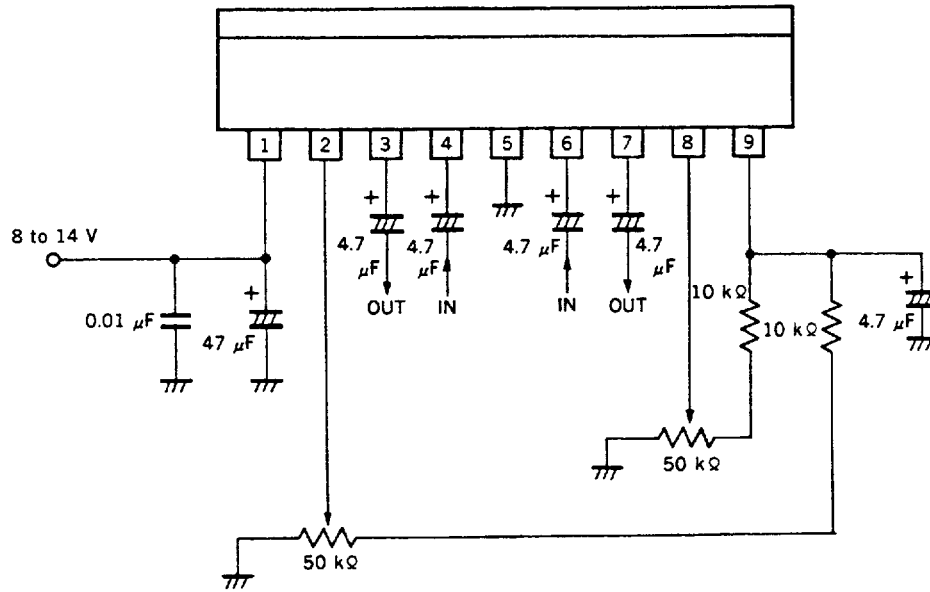

(2) To Balance The Two Attenuators

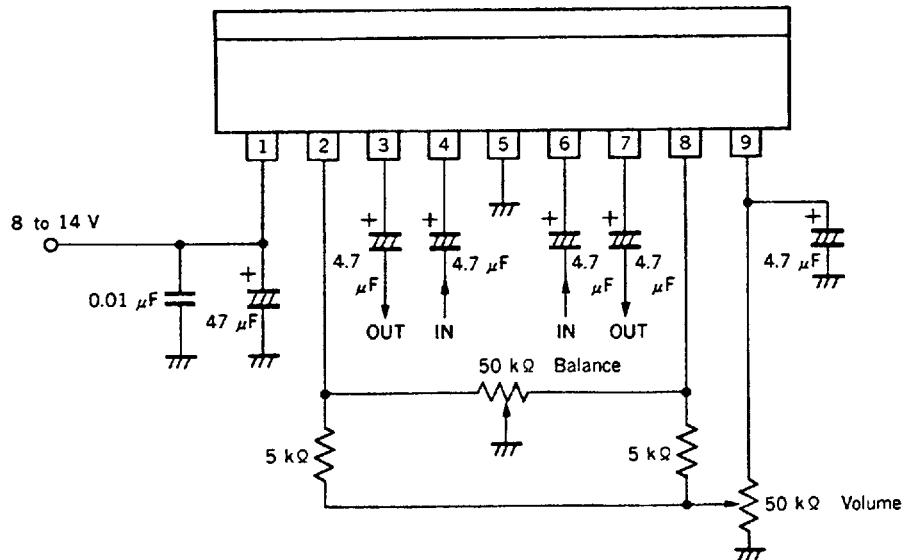

(3) To Control Both Attenuators Simultaneously

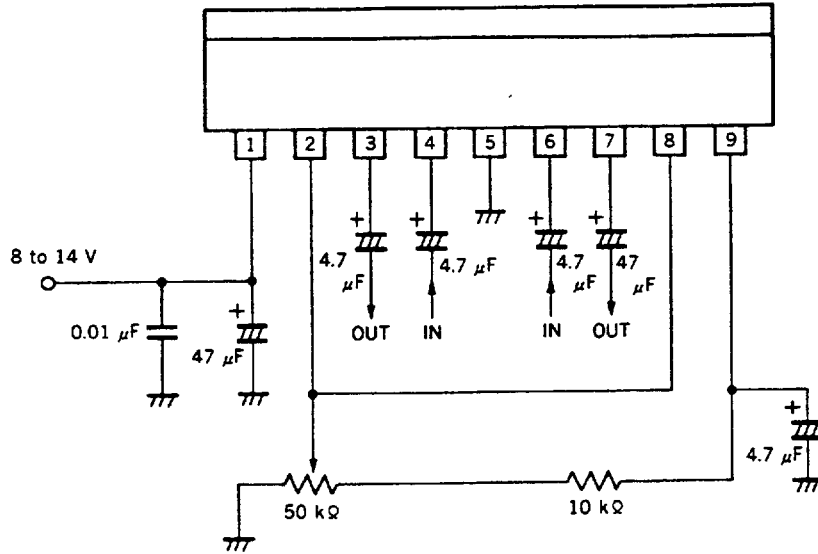

www.DataSheet4U.com

9 PIN PLASTIC SLIM SIP

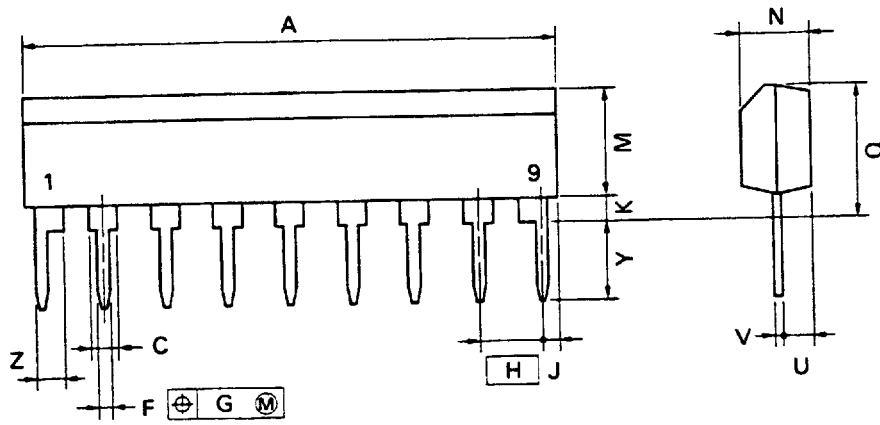

www.DataSheet4U.com

NOTE

Each lead centerline is located within 0.25 mm (0.01 inch) of its true position (T.P.) at maximum material condition.

P9HA-254B

ITEM	MILLIMETERS	INCHES
A	22.86 MAX.	0.9 MAX.
C	1.1 MIN.	0.043 MIN.
F	0.5 ^{-0.1}	0.02 ^{8/888}
G	0.25	0.01
H	2.54	0.1
J	1.27 MAX.	0.05 MAX.
K	0.51 MIN.	0.02 MIN.
M	5.08 MAX.	0.2 MAX.
N	2.8 ^{-0.2}	0.11 ^{8/888}
Q	5.75 MAX.	0.227 MAX.
U	1.5 MAX.	0.059 MAX.
V	0.25 ^{8/888}	0.01 ^{8/888}
Y	3.2 ^{-0.5}	0.126 ^{-0.02}
Z	1.1 MIN.	0.043 MIN.