

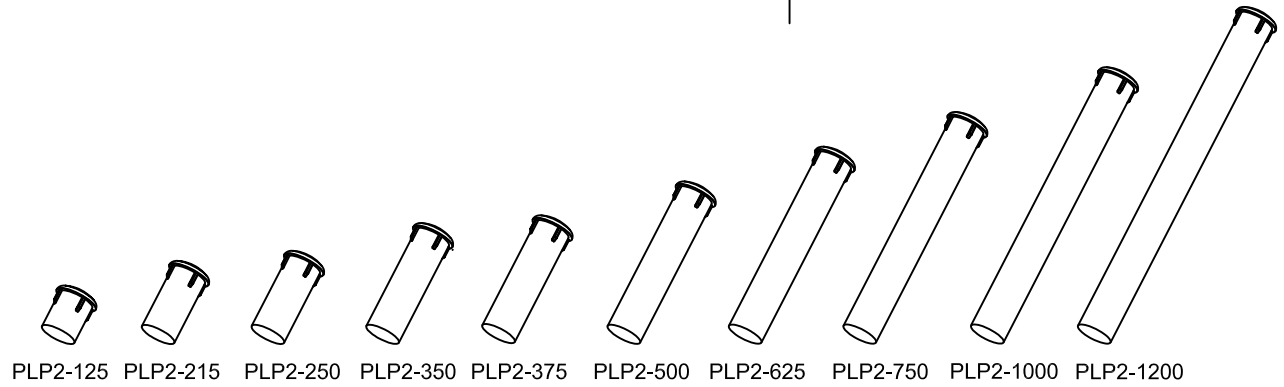

Part No.	X = Body Length
PLP2-125	0.125 (3.2mm)
PLP2-215	0.215 (5.5mm)
PLP2-250	0.250 (6.4mm)
PLP2-350	0.350 (8.9mm)
PLP2-375	0.375 (9.5mm)
PLP2-500	0.500 (12.7mm)
PLP2-625	0.625 (15.9mm)
PLP2-750	0.750 (19.0mm)
PLP2-1000	1.000 (25.4mm)
PLP2-1200	1.200 (30.5mm)

REV.	DESCRIPTION	DATE	APPROVED
H	Changed Ribs to Ref.	08/12/04	M. C.
J	Addition of PLP2-215.	08/31/04	M. C.
K	Addition of PLP2-1200.	03/10/06	M. C.
L	Addition of PLP2-1000.	10/05/06	M. C.
M	Updated Model.	04/01/09	T. Y.
N	Updated Rib Dimension.	04/10/09	T. Y.

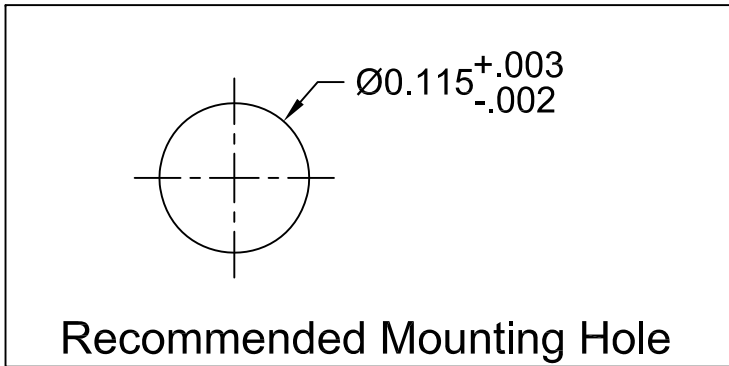
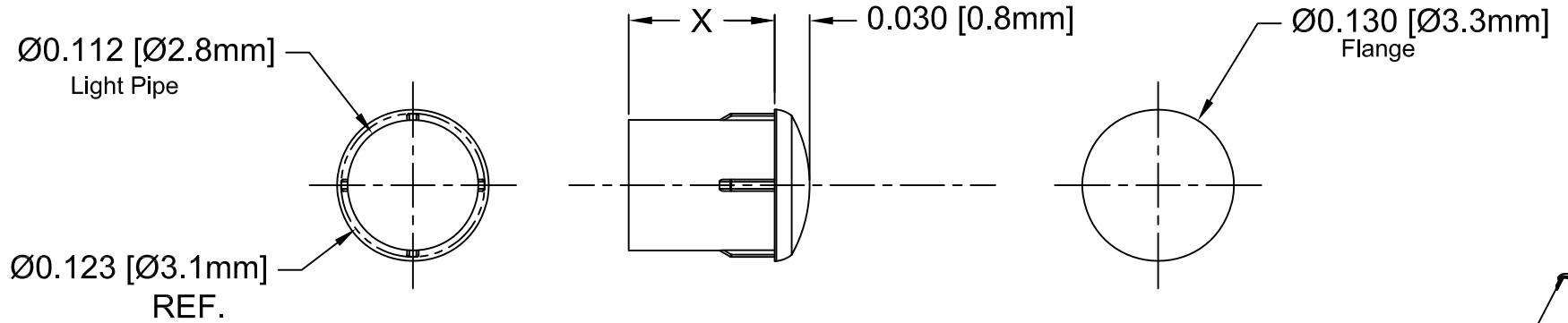

- 2. MATERIAL: POLYCARBONATE, 94V-0, CLEAR. BIVAR MATERIAL CODE 47-CR. SAM YANG CORPORATION POLYCARBONATE 3025N2 CLEAR.
- 1. GENERAL SPECIFICATIONS: BIVAR MOLDED COMPONENT SPECIFICATION BV00-E101.

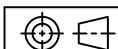
STANDARD TOLERANCE (UNLESS OTHERWISE SPECIFIED)		 BIVAR [®] 4 THOMAS, IRVINE, CA. 92618 TEL: (949) 951-8808 FAX: (949) 951-3974	
DECIMALS	ANGULAR		
.X ± .1	X° ± 1°	 TITLE: PRESS-FIT, PANEL MOUNT, LIGHT PIPE, FRONT MOUNT	
.XX ± .01			PART NO: PLP2-XXX REVISION: N
.XXX ± .005			
DESIGNED: Michael Chen	DATE: 01/16/02	DESIGNED: E. M. Muldoon DATE: 04/26/02	
CAD GENERATED DOCUMENT, DO NOT MEASURE DRAWING.			