

303, 433 MHz Remote Control Receiver

The RCR303 is a remote control receiver designed to provide a quick and cost effective solution for a variety of wireless applications. The receiver includes an external antenna, decoder and relay driver (open collector) outputs. The receiver offers excellent sensitivity and selectivity by the utilization of SAW technology and state-of-the-art low noise amplifiers. An external jack is provided for external antenna. Two different decoder options are available, one "learning" and the other with DIP switch settable addressing (Holtek decoder).



Features

- Matching Keyfob Transmitters Available
- 3 Relay Driver Outputs (Open Collector)
- Long Range-- Up to 1000 ft¹
- Integrated Decoder
- 12-Volt Operation
- Learning Decoder or Holtek Decoder
- Latched or Momentary Operation
- 2¹⁰ or 3⁸ Addresses
- Antenna Included (1/4-wave, non-ground plane)

Typical Applications

- Remote Control
 - Relays
 - Electronic Circuits
 - Motor Control
 - Industrial Applications

Part Ordering Information

<i>Frequency (MHz)</i>	<i>Model Number Holtek Decoder</i>	<i>Matching Key Chain Transmitter²</i>
303.825	RCR303A	KTX303Ax
315.000	RCR315A	KTX315Ax
418.000	RCR418A	KTX418Ax
433.920	RCR433A	KTX433Ax

<i>Frequency (MHz)</i>	<i>Model Number "Learning" Decoder</i>	<i>Matching Key Chain Transmitter²</i>
303.825	RCR303B	KTX303Bx
315.000	RCR315B	KTX315Bx
418.000	RCR418B	KTX418Bx
433.920	RCR433B	KTX433Bx

¹ Line of sight range, when used with a 1/4-wave ground plane antenna. With the included whip antenna, range is 300-400 ft. Optional antennas are available for longer range. See table below.

² x=Number of buttons (1, 2 or 3).

Electrical Characteristics

Sym	Parameter	Min	Typ	Max	Unit
V	Operating Voltage Range	9	12	16	Volts
I	Operating Current (activated)		52	70	mA
I	Operating Current (idle)		18		mA
	RF Sensitivity	-112	-113		DBm
V _D	Switched Voltage Capability			60	V
I _D	Switched Current Capacity			280	mA
R _{DS}	Output "ON" reistance to Ground		3		Ohms
Z _{out}	Antenna Input Impedance		50		Ohms
T _{op}	Operating Temperature	-20		+60	C

Decoder options

"A" Series Decoder

Address is set via cutting or shorting traces to create a "high", "low" or "open" circuit for each address bit. Setting the address for the transmitters is the same. Default from factory is all "low". A total of 3⁸ or 6561 address are available.

"B" Series Decoder

This receiver will learn up to 4 different transmitter ID's. A total of 2¹⁰ or 1024 addresses are available. The transmitters are pre-addressed at the factory.

To learn a transmitter, power up the receiver, remove the antenna, and then press the learn button. The Learn LED will light. With the transmitter close to the receiver (a few feet), press any button on the keyfob transmitter. When the Learn LED goes out, the transmitter has been learned. To learn another transmitter, repeat the process. When a fifth transmitter is learned, the first transmitter learned is eliminated from flash memory.

For operation in high EMI environments (such as around electric motors), the "B" series receiver performs somewhat better than the "A" series.

Block Diagram (A Series)

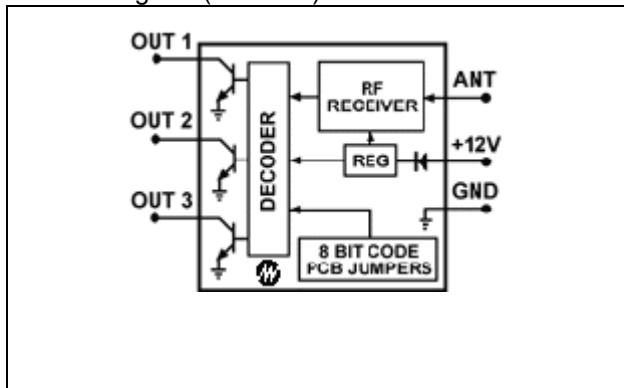

Application Circuit- Relay Driver

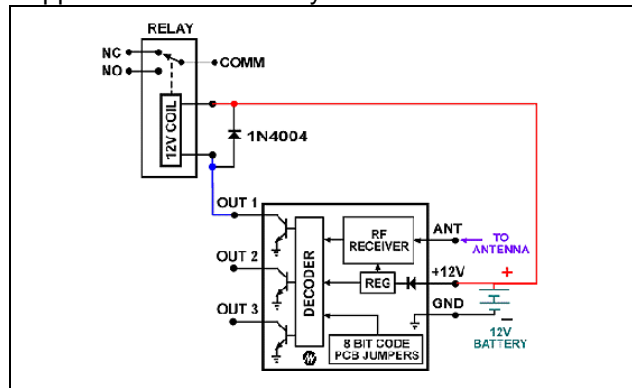

Mechanical Outline

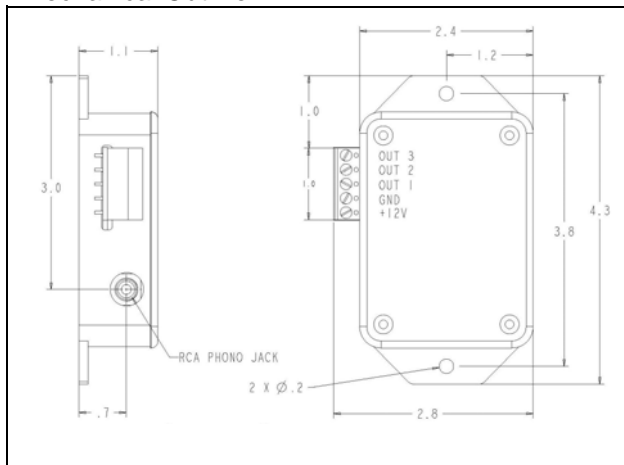

Test Circuit- LED Lights and Relay

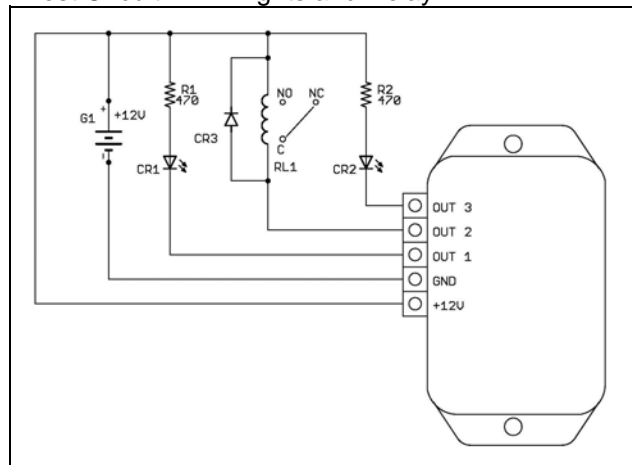

Specifications subject to change without notice or obligation.

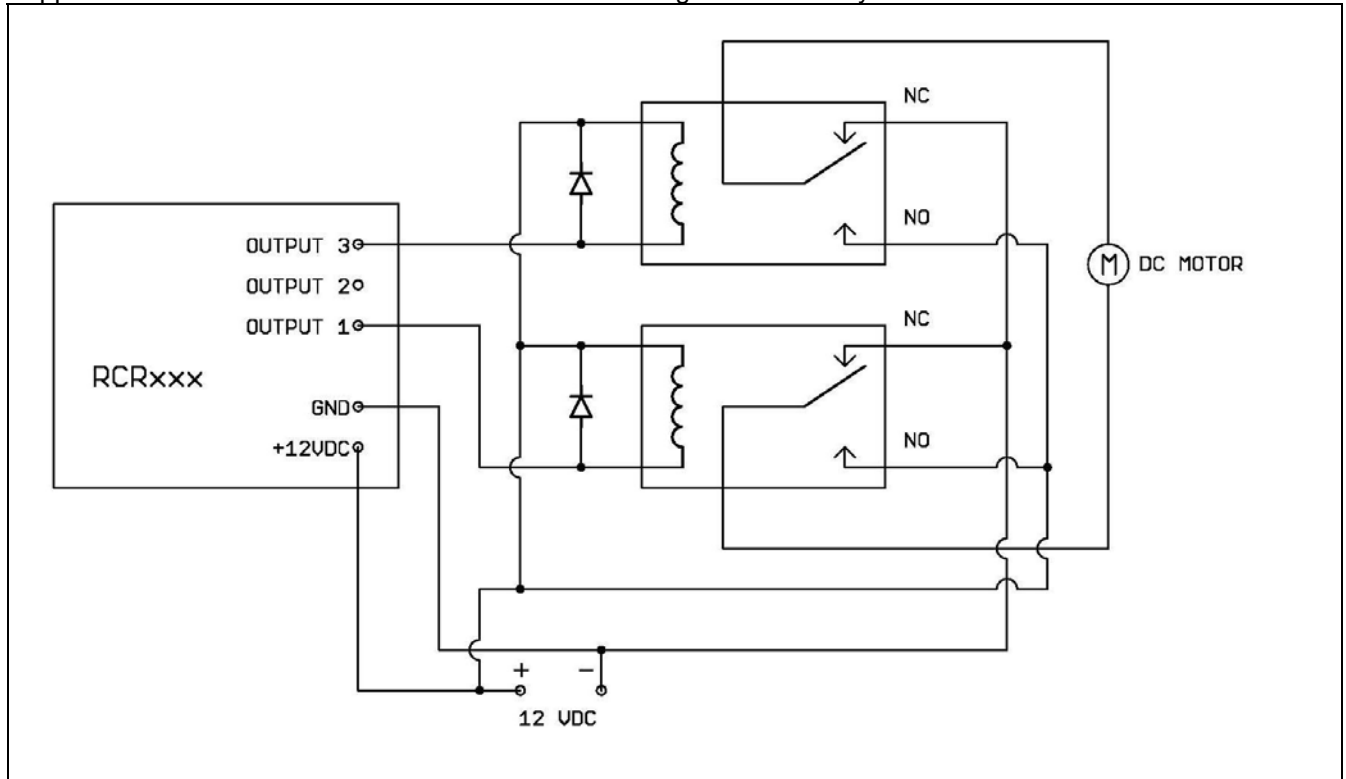
Application Circuit- Forward/Reverse Motor Circuit Using External Relays

Antenna Options

Model	Description	Gain (dBd)	Notes
800014/800015	¼-Wave Whip	-2	Included
DPxxx	Dipole	0	With 7' cable
DPAxxx	Amplified Dipole	3	Requires 12 VDC

xxx=frequency