



# TS2596

Preliminary

## 3A Step Down Switching Voltage Regulator

TO-220-5L



TO-263-5L



Pin assignment:

1. Input
2. Output
3. Ground
4. Feedback
5. Enable

**150KHz Oscillating Frequency**  
**Output Current up to 3A**  
**Enable Input Control**

### General Description

The TS2596 Series are step-down switching regulators with all required active functions. It is capable of driving 3A load with excellent line and load regulations. These devices are available in fixed output voltages of 3.3V, 5V, and an adjustable output version.

The TS2596 series operates at a switching frequency of 150kHz thus allowing smaller sized filter components than what would be needed with lower frequency switching regulators. It substantially not only reduces the area of board size but also the size of heat sink, and in some cases no heat sink is required. The  $\pm 4\%$  tolerance on output voltage within specified input voltages and output load conditions is guaranteed. Also, the oscillator frequency accuracy is within  $\pm 10\%$ . External shutdown is included. Featuring 70 $\mu$ A (typical) standby current. The output switch includes cycle-by-cycle current limiting, as well as thermal shutdown for full protection under fault conditions.

This series are offered in 5-pin TO-263, TO-220 package.

### Features

- ◇ Guaranteed 3A output current
- ◇ 3.3V, 5V, and adjustable versions
- ◇ Wide input voltage range, up to 30V
- ◇ Internal oscillator of 150KHz fixed frequency
- ◇ Wide adjust version output voltage range, from 1.23V to 25V  $\pm 4\%$  max. at over line and load conditions.
- ◇ Low standby current, typ. 70 $\mu$ A, at shutdown mode
- ◇ Requires only 4 external components
- ◇ Thermal shutdown and current limit protection
- ◇ P+ product enhancement tested

### Ordering Information

Part No.	Operating Temp.	Package
TS2596CZ5 <u>xx</u>	-40 ~ +125 °C	TO-220-5L
TS2596CZ5		
TS2596CM5 <u>xx</u>		TO-263-5L
TS2576CM5		

Note: Where xx denotes voltage option, available are 5V and 3.3V. Leave blank for adjustable version. Contact factory for additional voltage options.

### Applications

- ◇ LCD Monitors
- ◇ ADD-ON Cards Switching Regulators
- ◇ High Efficiency Step-Down Regulators
- ◇ Efficient Pre-regulator for Linear Regulator

### Absolute Maximum Rating

Input Voltage	V <sub>in</sub>	+30	V
ENABLE Pin Input Voltage	V <sub>in</sub> (operate)	-0.3V $\leq$ V $\leq$ V <sub>in</sub>	V
Power Dissipation	P <sub>D</sub>	Internal Limited	W
Operating Junction Temperature Range	T <sub>J</sub>	-40 ~ +125	°C
Storage Temperature Range	T <sub>STG</sub>	-65 ~ +150	°C
Lead Soldering Temperature (260 °C)		5	S



### Thermal Performance

Condition	Symbol	Limits	Unit
Thermal Resistance Junction to Ambient	$\Theta_{ja}$	30	°C/W
Thermal Resistance Junction to Case	$\Theta_{jc}$	3	

### Recommended Operating Conditions ( $T_a = 25^\circ\text{C}$ )

Condition	Symbol	Limits	Unit
Input Voltage	$V_{in}$	4.5 ~ 28	V
ENABLE Pin Input Voltage	$V_{in}$ (operate)	0 ~ +20	V

### Block Diagram

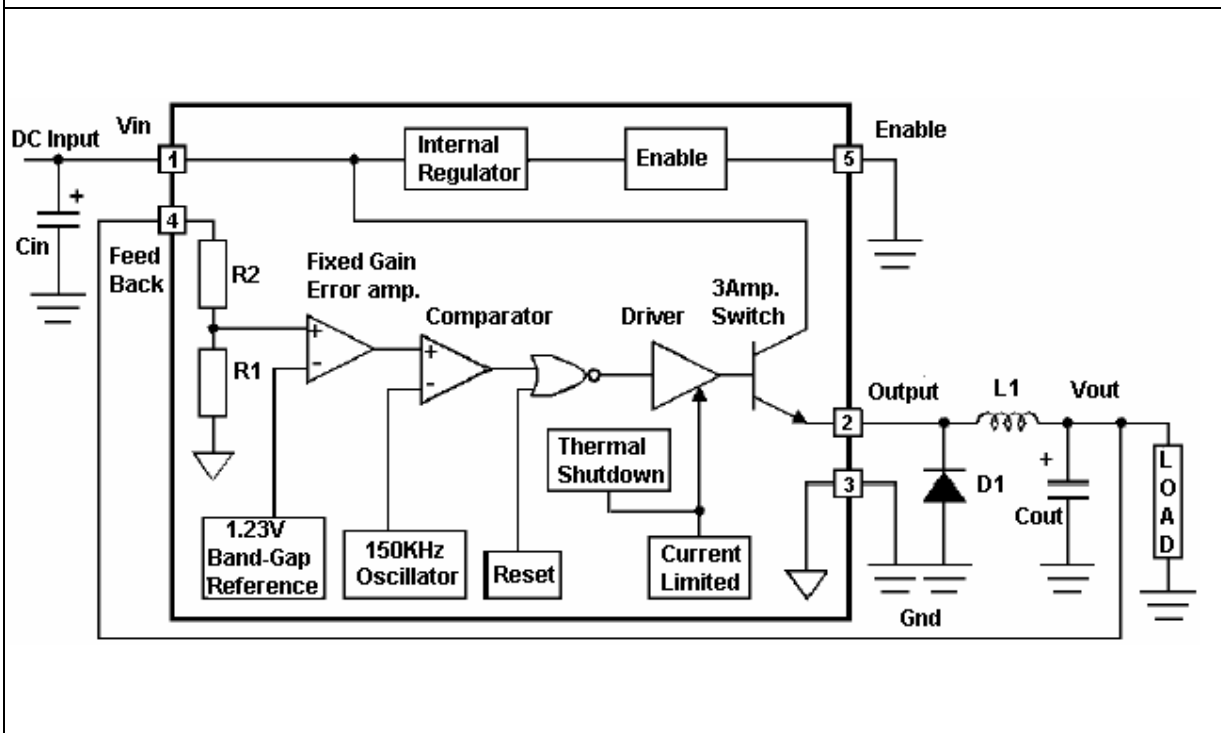

### Electrical Characteristics

$V_{in} = 12\text{V}$ ,  $I_L = 500\text{mA}$ ,  $T_a = 25^\circ\text{C}$  unless otherwise specified.

Parameter	Conditions	Min	Typ	Max	Unit
<b>TS2596-3.3V</b>					
Output Voltage (Note 1)	$0.2\text{A} \leq I_L \leq 3\text{A}$ , $5.07\text{V} \leq V_{in} \leq 30\text{V}$ (Figure 1)	$0.96 V_o $	3.3	$1.04 V_o $	V
Efficiency	$V_{in}=12\text{V}$ , $I_L=3\text{A}$	--	75	--	%
<b>TS2596-5V</b>					
Output Voltage (Note 1)	$0.2\text{A} \leq I_L \leq 3\text{A}$ , $8\text{V} \leq V_{in} \leq 40\text{V}$ (Figure 1)	$0.96 V_o $	5.0	$1.04 V_o $	V
Efficiency	$V_{in}=12\text{V}$ , $I_L=3\text{A}$	--	80	--	%



<b>Electrical Characteristics (Continued)</b>					
Vin = 12V, IL = 500mA, Ta = 25 °C unless otherwise specified.					
<b>TS2596 Adjustable</b>					
Feedback Voltage (Note 1)	0.2A ≤ IL ≤ 3A, 8V ≤ Vin ≤ 40V, Vout=5V (Figure 2)	0.96 Vo	1.23	1.04 Vo	V
Efficiency	Vin=12V, Vout=5V, IL=3A	--	75	--	%
<b>All Output Voltage Version</b> (Vin= 12V, IL = 500mA)					
Oscillator Frequency (Note 2)		127	150	173	kHz
Quiescent Current (Note 3)		--	5	10	mA
Standby Current	ENABLE =5V	--	70	200	uA
Saturation Voltage (Note 4)	ILoad=3A	--	1.2	1.5	V
Feedback Bias Current	VOUT=5V (Adj. Version only)	--	50	100	nA
Duty Cycle (Note 5)	Operating (ON)	93	98	--	%
Current Limit (Note 2)(Note 4)		--	4.5	--	A
Output Leakage Current (Note 3)	VOUT=0V	--	0.3	2	mA
	VOUT=-1V	--	7.5	30	
ENABLE Threshold Voltage	VIH (VOUT=0V)	2.0	--	--	V
	VIL(VOUT=Normal Output Voltage)	--	--	0.6	
ENABLE Input Current	I <sub>IH</sub> (ENABLE =5V)	--	12	30	uA
	I <sub>IH</sub> (ENABLE =0V)	--	0	10	

Note 1: External components such as the catch diode, inductor, input and output capacitors can affect switching regulator system performance. Refer to Application information for details.

Note 2: The oscillator frequency reduces when the second stage current limit is activated. The amount of reduction is determined by the severity of current over load.

Note 3: For these parameters, FB is removed from V<sub>OUT</sub> and connected to +12V to force the output transistor OFF.

Note 4: V<sub>OUT</sub> pin sourcing current. No diode, inductor or capacitor connected to V<sub>OUT</sub>.

Note 5: FB is removed from V<sub>OUT</sub> and connected to 0V.

### Typical Application Circuit

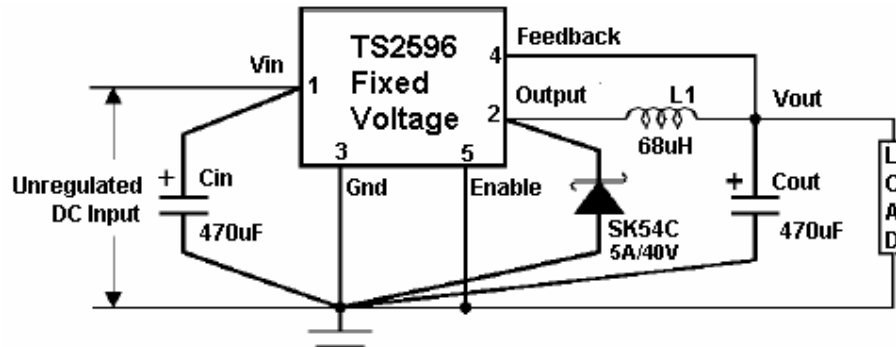
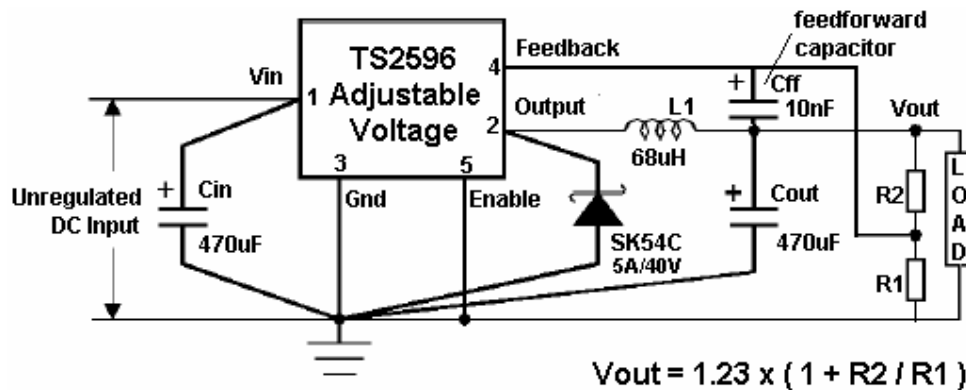
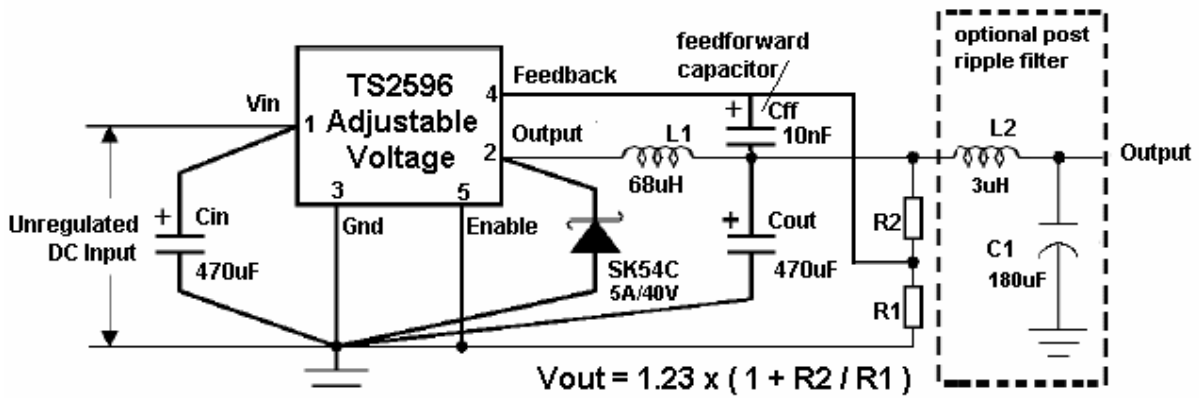

Figure 1 Fixed Voltage Version



$$V_{out} = 1.23 \times (1 + R2 / R1)$$

Figure 2: Adjustable Voltage Version



$$V_{out} = 1.23 \times (1 + R2 / R1)$$

Figure 3: LC filter for Low Output Ripple



## Application Data

### Quick Design Component Selection Table for Fixed Output

Input / Output Condition			Inductor		Output Capacitor			
Output (V)	Load current (A)	Max. Input voltage (V)	Inductance (uH)	Current (A)	Nichicon PL series		Sprague 595D series	
					uF	V	uF	V
5	3	8	22	3.5	560	25	330	10
		15	33	3.5	330	35	330	10
		25	47	3.5	270	35	330	10
	2	9	22	3.1	470	25	330	10
		15	68	3.1	180	35	270	10
		25	68	3.1	180	35	270	10
3.3	3	5	22	3.5	470	25	390	6.3
		12	22	3.5	560	35	390	6.3
		25	33	3.5	680	35	390	6.3
	2	6	22	3.1	470	25	390	6.3
		12	33	3.1	330	35	390	6.3
		25	47	3.1	330	35	330	10

### Quick Design Component Selection Table for Adjustable Output

Input / Output Condition Output (V)	Output Capacitor				Feedforward	
	Nichicon PL series		Sprague 595D series		Capacitor	
	uF	V	uF	V	Value	Unit
2	820	35	330	10	33	nF
4	470	35	330	10	10	nF
6	470	25	330	10	3.3	nF
9	330	25	330	10	1.5	nF
12	330	25	270	10	1	nF
15	220	35	270	10	680	pF
24	150	35	390	6.3	560	pF

### Schottky Diode Selection Table

Reverse Voltage (V)	Forward Rectified Current (4~6A)	
	Surface Mount	Through Hole
20	--	SR502
30	SK53C	SR503
40	SK54C	SR504

(Taiwan Semiconductor Part Number)

## TO-220-5L Mechanical Drawing

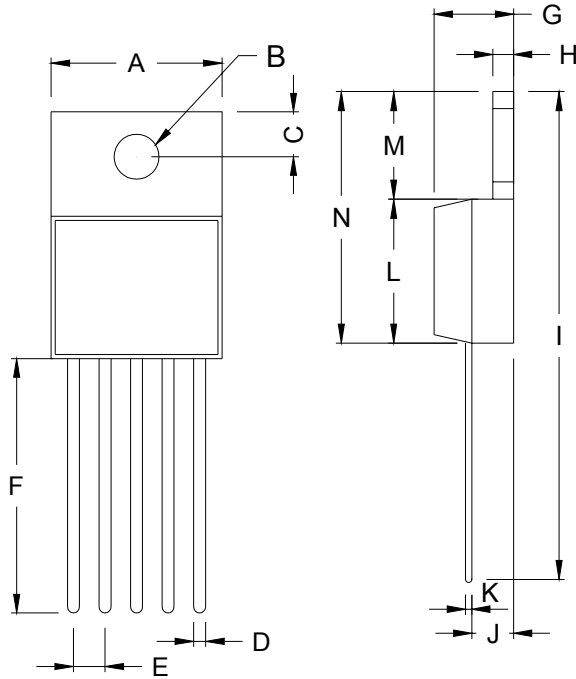

DIM	TO-220 DIMENSION			
	MILLIMETERS		INCHES	
	MIN	MAX	MIN	MAX
A	10.00	10.50	0.394	0.413
B	3.240	4.440	0.128	0.175
C	2.440	2.940	0.096	0.116
D	0.260	1.020	0.010	0.040
E	1.570	1.830	0.062	0.072
F	13.31	14.13	0.524	0.556
G	4.475	5.225	0.176	0.206
H	1.170	1.370	0.046	0.054
I	27.60	29.44	1.087	1.159
J	2.175	2.925	0.086	0.115
K	0.297	0.477	0.012	0.019
L	8.280	8.800	0.326	0.346
M	6.010	6.510	0.237	0.256
N	14.29	15.31	0.563	0.603

## TO-263-5L Mechanical Drawing

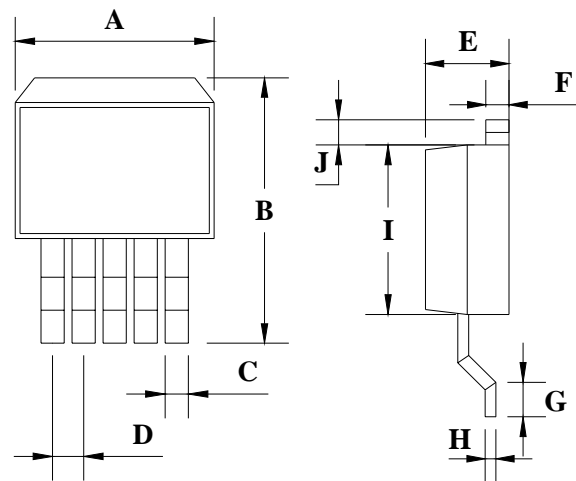

DIM	TO-263 DIMENSION			
	MILLIMETERS		INCHES	
	MIN	MAX	MIN	MAX
A	10.220	10.260	0.402	0.404
B	14.600	15.870	0.575	0.625
C	0.750	0.770	0.030	0.030
D	1.573	1.827	0.062	0.072
E	4.560	4.570	0.179	0.180
F	1.240	1.270	0.049	0.050
G	2.280	2.790	0.090	0.110
H	0.280	0.320	0.011	0.013
I	8.240	8.280	0.324	0.326
J	1.540	1.800	0.060	0.071