

# DALLAS

## SEMICONDUCTOR

# DS1411

## Serial Port iButton™ Holder

### FEATURES

- Small size, true-ground interface to an RS232 COM Port for reading and writing iButton devices
- Works with bipolar logic signals of  $\pm 5V$  to  $\pm 12V$  (RS232C) as well as unipolar signals of 5V to 12V
- Supports reading and writing at regular and Overdrive speeds
- Provides strong pullup to 5V for Temperature iButton, Crypto iButton and EEPROM iButton
- Communicates at data rates of 9.6k (default), 19.2k, 57.6k and 115.2k bits/s
- Powered entirely from an RS232 interface
- Standard DB female connector for mating to the COM Port of a computer with DS9098 iButton Retainer for a single iButton or MicroLAN Cable (DS1402x)

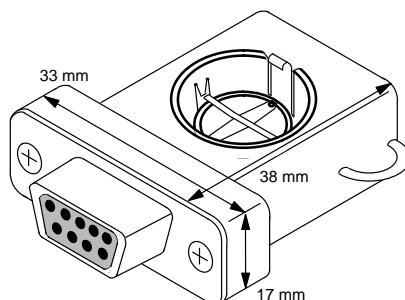

### SCHEMATIC

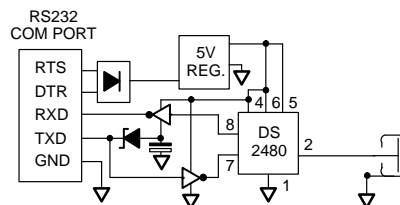

### ORDERING INFORMATION

DS1411 DB-9 Connector

### DESCRIPTION

The DS1411 is a sophisticated RS232 to 1-Wire™ adapter and iButton holder which performs RS232 level conversion and actively generates the 1-Wire communication signals. Together with an adequate TMEX software driver it enables an IBM-compatible PC or laptop computer to directly read all and write any non-EPROM iButton devices. The DS1411 has a DS9098 retainer for a single F5 MicroCan and can replace the DS9097U-09 in applications that use only a single iButton. Multiple iButtons can be connected using standard MicroLAN Cables and button holders (see DS1401 and DS1402x data sheets). 1-Wire communication is supported by the adapter for regular as well as Overdrive speed. The serial port must support a data transmission rate of 9600

bits/s. Under software control, the adapter can be set up for RS232 data rates of 19200, 57600 and 115200 bits per second. The two higher rates are recommended for communication at Overdrive speed with Overdrive capable devices. Since the DS1411 operates in a byte mode, every data byte received from the RS232 port generates eight time slots on the 1-Wire bus.

The DS1411 is based on the DS2480 Serial 1-Wire Line Driver chip and therefore is **not a plug-in replacement for the DS1412** Serial Port Adapter. The RXD/ TXD Polarity Select input of the DS2480 is tied to  $V_{DD}$  (non-inverting).