

PLEASE CHECK WWW.MOLEX.COM FOR LATEST PART INFORMATION

Part Number: **0039000066**
Status: **Active**
Overview: [minifit_jr](#)
Description: 4.20mm (.165") Pitch Mini-Fit™ Crimp Terminal, Female, Phosphor Bronze, Tin (Sn), 22-28 AWG, Bag

Documents:

Test Summary (PDF)	Product Specification PS-5556-001 (PDF)
Drawing (PDF)	Product Specification PS-5556-002 (PDF)
Product Specification PS-54111-002 (PDF)	Product Specification PS-5556-003 (PDF)
Product Specification PS-54452-007 (PDF)	RoHS Certificate of Compliance (PDF)

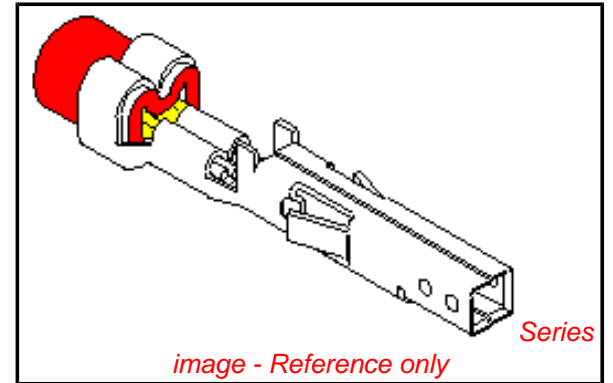

General

Product Family	Crimp Terminals
Series	5556
Crimp Quality Equipment	Yes
Overview	minifit_jr
Product Name	Mini-Fit®

Physical

Durability (mating cycles max)	30
Gender	Receptacle
Material - Metal	Phosphor Bronze
Material - Plating Mating	Tin
Material - Plating Termination	Tin
Packaging Type	Bag
Plating min: Mating (µin)	36
Plating min: Mating (µm)	0.90
Plating min: Termination (µin)	36
Plating min: Termination (µm)	0.90
Termination Interface: Style	Crimp or Compression
Wire Insulation Diameter	0.90-1.80mm (.035-.071")
Wire Size AWG	22, 24, 26, 28
Wire Size mm²	N/A

Electrical

Current - Maximum per Contact	9A
Voltage - Maximum	600V

Material Info

Old Part Number	5556PBT2L
-----------------	-----------

Reference - Drawing Numbers

Packaging Specification	PK-5556-003
Product Specification	PS-54111-002, PS-54452-007, PS-5556-001, PS-5556-002, PS-5556-003, RPS-54111-004
Sales Drawing	SD-5556****
Test Summary	TS-5556-002

EU RoHS

ELV and RoHS Compliant
REACH SVHC Contains SVHC: No
Halogen-Free Status

China RoHS



Need more information on product environmental compliance?

Email productcompliance@molex.com
 For a multiple part number RoHS Certificate of Compliance, [click here](#)

Please visit the [Contact Us](#) section for any non-product compliance questions.

Search Parts in this Series

5556Series

Mates With

5558 Male Crimp Terminals. Mini-Fit Jr.™ Header, Dual Row, 5566 , 5569

Use With

5557 Mini-Fit Jr.™ Receptacle Housing, 30067 TPA, 42474 BMI Panel Mount, 5559 Mini-Fit Jr.™ Plug Housing, Dual Row

Application Tooling | FAQ

Tooling specifications and manuals are found by selecting the products below. Crimp Height Specifications are then contained in the Application Tooling Specification document.

Global

Description	Product #
Hand Crimp Tool for Mini-Fit Jr.™ Crimp Terminals	0638191000
Extraction Tool	0011030044

Japan

Description

Product #

Handtool - Straight 0570385300

Action

Hand Crimp Tool 0570645000

This document was generated on 06/01/2010

PLEASE CHECK WWW.MOLEX.COM FOR LATEST PART INFORMATION

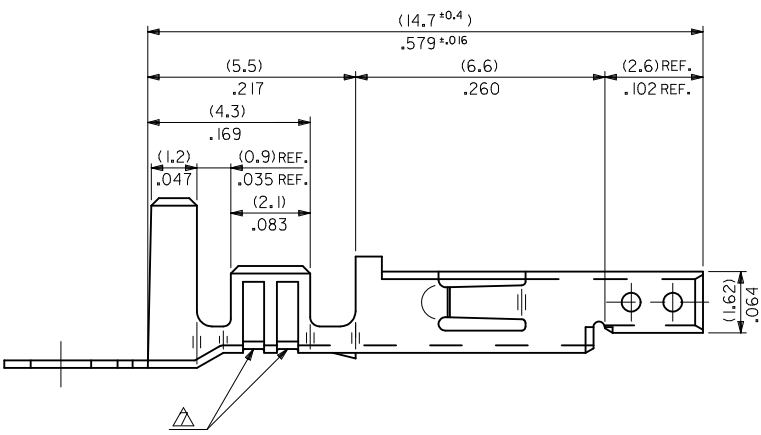
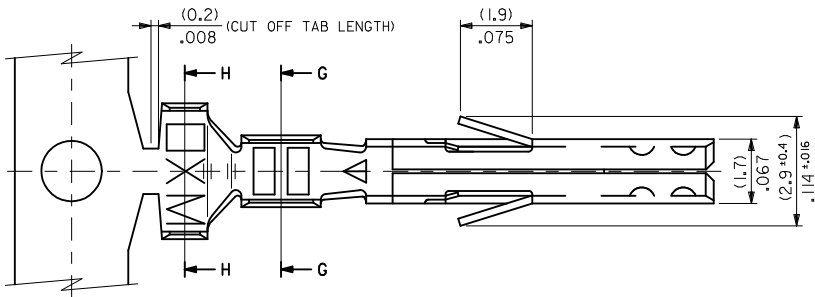

NOTES

1. MATERIAL: SEE CHART.
2. FINISH: SEE CHART.
3. PRODUCT SPECIFICATION: PS-5556-001, PS-5556-002, PS-5556-003.
4. PACKAGING SPECIFICATION: PK-5556-001 FOR CHAIN TERMINALS
PK-5556-003 FOR LOOSE TERMINALS.
5. MATES WITH: 5558, 5566, 5569, 30069, 30070, 42440, 42404, 43879, 43810, 44068.
6. APPLICABLE HOUSING: 5557, 30067, 44516, OR 42474.
7. THE NUMBER OF SERRATIONS TO BE ONE FOR WIRE RANGE #22-28.
8. WHEN TERMINALS ARE INSTALLED IN THE HOUSING THE WIRES ARE TO BE DRESSED IN SUCH A MANNER TO ALLOW THE TERMINALS TO FLOAT FREELY IN THE POCKET.
9. THIS TERMINAL IS DESIGNED FOR SINGLE WIRE CRIMPING.
10. PART CONFORMS TO CLASS "B" REQUIREMENTS OF COSMETIC SPECIFICATION PS-45499-002.

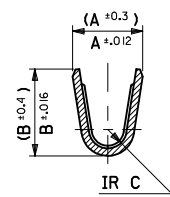

SECT. G-G

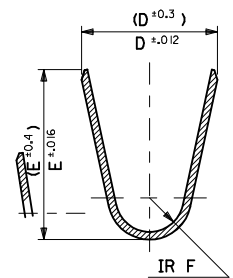

SECT. H-H

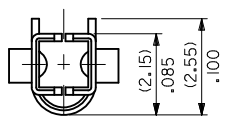

ADD NOTES EC NO: UCP2010-2205 DRWN: JAGUILAR 2010/03/01 CHKD: 2010/03/01 2010/04/09 APPR: FSMITH 2010/04/09	DESCRIPTION REV	QUALITY SYMBOLS	GENERAL TOLERANCES (UNLESS SPECIFIED)	DIMENSION STYLE MM/IN	SCALE 10:1	DESIGN UNITS METRIC	THIRD ANGLE PROJECTION															
		$\nabla = 0$ $\nabla = 0$ $\nabla = 0$	<table border="1"> <tr> <th></th> <th>mm</th> <th>INCH</th> </tr> <tr> <td>4 PLACES</td> <td>± .008</td> <td>± .0003</td> </tr> <tr> <td>3 PLACES</td> <td>± .008</td> <td>± .0008</td> </tr> <tr> <td>2 PLACES</td> <td>± .02</td> <td>± .0008</td> </tr> <tr> <td>1 PLACE</td> <td>± .02</td> <td>± .0008</td> </tr> </table>		mm	INCH	4 PLACES	± .008	± .0003	3 PLACES	± .008	± .0008	2 PLACES	± .02	± .0008	1 PLACE	± .02	± .0008	DRAWN BY H.HIRAMOTO DATE 1991/5/18 CHECKED BY M. FUKUSHIMA DATE 1998/11/09 APPROVED BY FSMITH DATE 2010/04/09	TITLE MINI FIT JR OVERALL TIN FEMALE CRIMP TERMINAL	MATERIAL NO. SD-5556****	SHEET NO. 1 OF 2
			mm	INCH																		
		4 PLACES	± .008	± .0003																		
3 PLACES	± .008	± .0008																				
2 PLACES	± .02	± .0008																				
1 PLACE	± .02	± .0008																				
ANGULAR ± 3° DRAFT WHERE APPLICABLE MUST REMAIN WITHIN DIMENSIONS	SEE CHART THIS DRAWING CONTAINS INFORMATION THAT IS PROPRIETARY TO MOLEX INCORPORATED AND SHOULD NOT BE USED WITHOUT WRITTEN PERMISSION	MOLEX MOLEX INCORPORATED DOCUMENT NO.																				

TIN OVER NICKEL PLATED PHOSPHOR BRONZE	(0.9) .035	(4.5) .177	(3.6) .142	(0.6) .024	(2.7) .106	(2.3) .091	∅ (3.1) .122 MAX.	# 16	39-00-0119	5556 PBS3L	LOOSE
	(0.6) .024	(2.3) .091	(2.3) .091	(0.4) .016	(1.65) .065	(1.8) .071	∅ (0.9-1.8) .035-.071	#22-28	↑ -0118	↑ PBS3	CHAIN
	(0.9) .035	(4.5) .177	(3.6) .142	(0.5) .020	(2.3) .091	(1.9) .075	∅ (1.3-3.1) .051-.122	# 18-24	-0117	PBS2L	LOOSE
TIN PLATED PHOSPHOR BRONZE	(0.9) .035	(4.5) .177	(3.6) .142	(0.6) .024	(2.7) .106	(2.3) .091	∅ (3.1) .122 MAX.	# 16	-0116	PBS2	CHAIN
	(0.6) .024	(2.3) .091	(2.3) .091	(0.4) .016	(1.65) .065	(1.8) .071	∅ (0.9-1.8) .035-.071	#22-28	-0115	PBSL	LOOSE
	(0.9) .035	(4.5) .177	(3.6) .142	(0.5) .020	(2.3) .091	(1.9) .075	∅ (1.3-3.1) .051-.122	# 18-24	-0114	PBS	CHAIN
TIN OVER NICKEL PLATED BRASS	(0.9) .035	(4.5) .177	(3.6) .142	(0.6) .024	(2.7) .106	(2.3) .091	∅ (3.1) .122 MAX.	# 16	-0080	PBT3L	LOOSE
	(0.6) .024	(2.3) .091	(2.3) .091	(0.4) .016	(1.65) .065	(1.8) .071	∅ (0.9-1.8) .035-.071	#22-28	-0079	PBT3	CHAIN
	(0.9) .035	(4.5) .177	(3.6) .142	(0.5) .020	(2.3) .091	(1.9) .075	∅ (1.3-3.1) .051-.122	# 18-24	-0066	PBT2L	LOOSE
TIN OVER COPPER PLATED BRASS	(0.9) .035	(4.5) .177	(3.6) .142	(0.6) .024	(2.7) .106	(2.3) .091	∅ (3.1) .122 MAX.	# 16	-0065	PBT2	CHAIN
	(0.6) .024	(2.3) .091	(2.3) .091	(0.4) .016	(1.65) .065	(1.8) .071	∅ (0.9-1.8) .035-.071	#22-28	-0060	PBTL	LOOSE
	(0.9) .035	(4.5) .177	(3.6) .142	(0.5) .020	(2.3) .091	(1.9) .075	∅ (1.3-3.1) .051-.122	# 18-24	-0059	PBT	CHAIN
MATERIAL	F	E	D	C	B	A	INS. RANGE	WIRE RANGE	EDP NO.	ENG. NO.	FORM

SEE SHEET 1 EC NO: UCP2010-2205 DRWN: J JAGUILAR 2010/03/01 CHKD: JBELL 2010/03/01 APPR: FSMITH 2010/04/09 K	QUALITY SYMBOLS ∇=0 ∇=0 ∇=0	GENERAL TOLERANCES (UNLESS SPECIFIED) mm INCH 4 PLACES ± --- ± --- 3 PLACES ± --- ± .008 2 PLACES ± 0.2 ± .008 1 PLACE ± 0.2 ± --- ANGULAR ± ---°	DIMENSION STYLE MM/IN DRAWN BY DATE H.HIRAMOTO 1991/5/18 CHECKED BY DATE M. FUKUSHIMA 1998/11/19 APPROVED BY DATE F&M HUNISHI 2008/04/19	SCALE --- DESIGN UNITS METRIC THIRD ANGLE PROJECTION	TITLE MINI FIT JR OVERALL TIN FEMALE CRIMP TERMINAL MOLEX INCORPORATED DOCUMENT NO. SD-5556**** SHEET NO. 2 OF 2	
	DRAFT WHERE APPLICABLE MUST REMAIN WITHIN DIMENSIONS		SEE CHART	THIS DRAWING CONTAINS INFORMATION THAT IS PROPRIETARY TO MOLEX INCORPORATED AND SHOULD NOT BE USED WITHOUT WRITTEN PERMISSION		
			SIZE B			