

SFF130/59

14849 Firestone Boulevard · La Mirada, CA 90638
 Phone: (714) 670-SSDI (7734) · Fax: (714) 522-7424

Designer's Data Sheet

FEATURES:

- Rugged construction with poly silicon gate
- Low RDS(on) and high transconductance
- Excellent high temperature stability
- Very fast switching speed
- Fast recovery and superior dv/dt performance
- Increased reverse energy capability
- Low input and transfer capacitance for easy paralleling
- Hermetically sealed stud package
- TX, TXV and Space Level screening available
- Replaces: IRF130 Types

**14 AMP
 100 VOLTS
 0.16 Ω
 N-CHANNEL
 POWER MOSFET**

TO-59

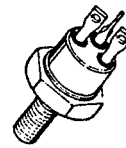

MAXIMUM RATINGS

CHARACTERISTIC	SYMBOL	VALUE	UNIT
Drain to Source Voltage	V _{DS}	100	Volts
Gate to Source Voltage	V _{GS}	± 20	Volts
Continuous Drain Current @TC=25°C @TC=100°C	I _D	14 9	Amps
Operating and Storage Temperature	T _{OP} & T _{STG}	-55 to +150	°C
Thermal Resistance, Junction to Case	R _{θJC}	3.5	°C/W
Total Device Dissipation @ TC=25°C Total Device Dissipation @ TC=55°C	P _D	35 27	Watts

PACKAGE OUTLINE: TO-59

PIN OUT:

- PIN 1: DRAIN
 PIN 2: SOURCE
 PIN 3: GATE**

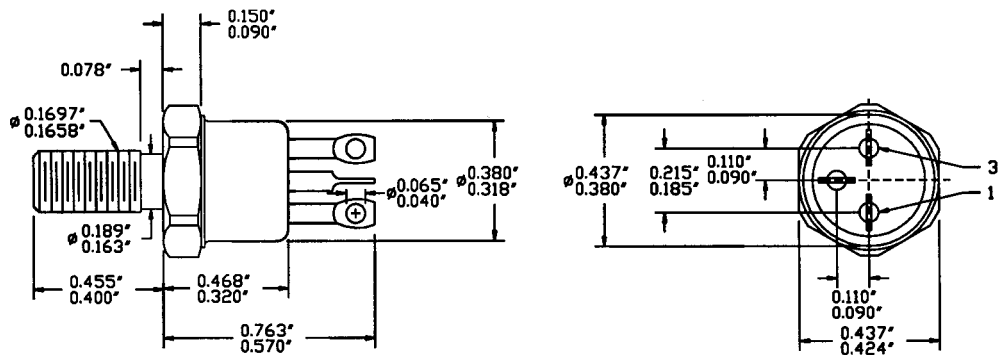

NOTE: All specifications are subject to change without notification. SCD's for these devices should be reviewed by SSDI prior to release.

DATA SHEET #: F0027 B

MED

SFF130/59

PRELIMINARY



SOLID STATE DEVICES, INC

14849 Firestone Boulevard · La Mirada, CA 90638
 Phone: (714) 670-SSDI (7734) · Fax: (714) 522-7424

ELECTRICAL CHARACTERISTICS @ T_J=25°C (Unless Otherwise Specified)

RATING	SYMBOL	MIN	TYP	MAX	UNIT	
Drain to Source Breakdown Voltage (V _{GS} =0 V, I _D =250μA)	BV_{DSS}	100	---	---	V	
Temperature Coefficient of Breakdown Voltage	$\frac{\Delta BV_{DSS}}{\Delta T_J}$	---	0.13	---	V/°C	
Drain to Source on State Resistance (V _{GS} =10 V)	I _D = 9A I _D = 14A R_{DS(on)}	---	0.13 0.14	0.18 0.21	Ω	
On State Drain Current (V _{DS} > I _{D(on)} X R _{DS(on)} Max, V _{GS} =10 V)	I_{D(on)}	14	---	---	A	
Gate Threshold Voltage (V _{DS} =V _{GS} , I _D =250μA)	V_{GS(th)}	2	2.8	4	V	
Forward Transconductance (V _{DS} > I _{D(on)} X R _{DS(on)} Max, I _{DS} =60% rated I _D)	g_{fs}	4.6	7	---	S(Ω)	
Zero Gate Voltage Drain Current (V _{DS} =80% rated voltage, V _{GS} =0 V) (V _{DS} =80% rated V _{DS} , V _{GS} =0 V, T _A =125°C)	I_{DSS}	---	---	25 250	μA	
Gate to Source Leakage Forward Gate to Source Leakage Reverse	At rated V _{GS}	I_{GSS}	---	100 -100	nA	
Total Gate Charge Gate to Source Charge Gate to Drain Charge	V _{GS} =10 Volts 50% rated V _{DS} Rated I _D	Q_g Q_{gs} Q_{gd}	12 1.5 5	20 ---	35 10 15	nC
Turn on Delay Time Rise Time Turn Off Delay Time Fall Time	V _{DD} =50% rated V _{DS} I _D = 14A R _G =7.5Ω	t_{d(on)} t_r t_{d(off)} t_f	---	9.5 42 22 25	35 80 60 45	nsec
Diode Forward Voltage (I _S =rated I _D , V _{GS} =0 V, T _J =25°C)	V_{SD}	---	1.15	1.5	V	
Diode Reverse Recovery Time Reverse Recovery Charge	T _J =25°C I _F =rated I _D di/dt=100 A/ sec	t_{rr} Q_{RR}	---	120 0.7	300 3	nsec μC
Input Capacitance Output Capacitance Reverse Transfer Capacitance	V _{GS} =0 Volts V _{DS} =25 Volts f= 1 MHz	C_{iss} C_{oss} C_{rss}	---	650 250 44	---	pF

SAFE OPERATING AREA (S.O.A.)
 T_C = 25 C, D.C. CONDITION

