



QUICKSWITCH® PRODUCTS
HIGH-SPEED CMOS
SYNCHROSWITCH™
32:16 MUX/DEMUX

IDTQS34XS257

FEATURES:

- Enhanced N channel FET with no inherent diode to Vcc
- Bidirectional signal flow
- Flow-through pinout
- Zero propagation delay, zero ground bounce
- 16 banks of 2:1 Mux/Demux
- Port select synchronous to the clock
- Clock enable and asynchronous enable
- Undershoot clamp diodes on all switch and control inputs
- Asynchronous SEL option
- Break-before-make feature
- Bus-hold eliminates floating bus lines and reduces static power consumption
- Available in 80-pin Millipaq package

DESCRIPTION:

The QS34XS257 is a high-speed CMOS quad 32:16 multiplexer/demultiplexer. It is organized as four independent quad 2:1 mux/demux blocks. Port selection and connection, controlled by SEL signals, can be either asynchronous or synchronous. In the synchronous mode, the A or B port to Y port connection is updated on the rising edge of the input clock CLK. Once the port-to-port connection is made, data flow can be bidirectional with a typical 250ps propagation delay through the switch. Clock Enable, overriding Asynchronous Enable, and Asynchronous Select controls provide additional design flexibility.

Synchronous controls ease timing constraints in many high speed data mux/demux applications, such as bank interleaving. The QS34XS257 is available in the space-saving, 80-pin dual-in-line Millipaq package.

The QS34XS257 is characterized for operation at -40°C to +85°C.

APPLICATIONS:

- Memory interleaving

FUNCTIONAL BLOCK DIAGRAM

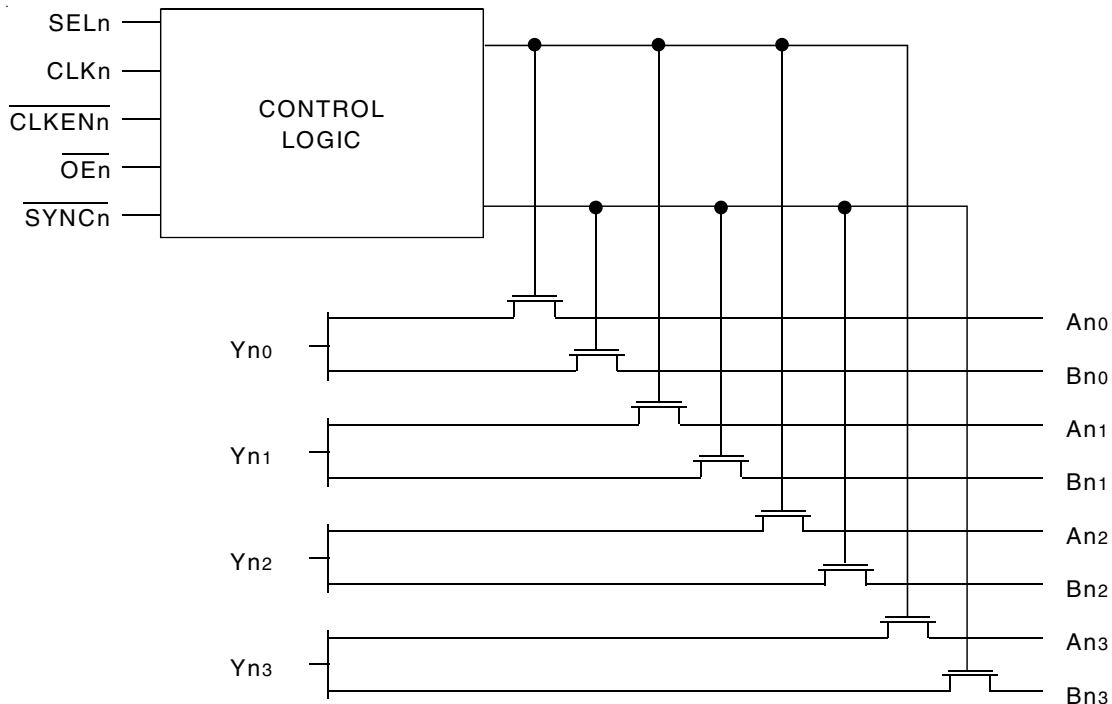

NOTE:
1. One of four blocks shown.

The IDT logo is a registered trademark of Integrated Device Technology, Inc.

INDUSTRIAL TEMPERATURE RANGE

JUNE 2006

PIN CONFIGURATION

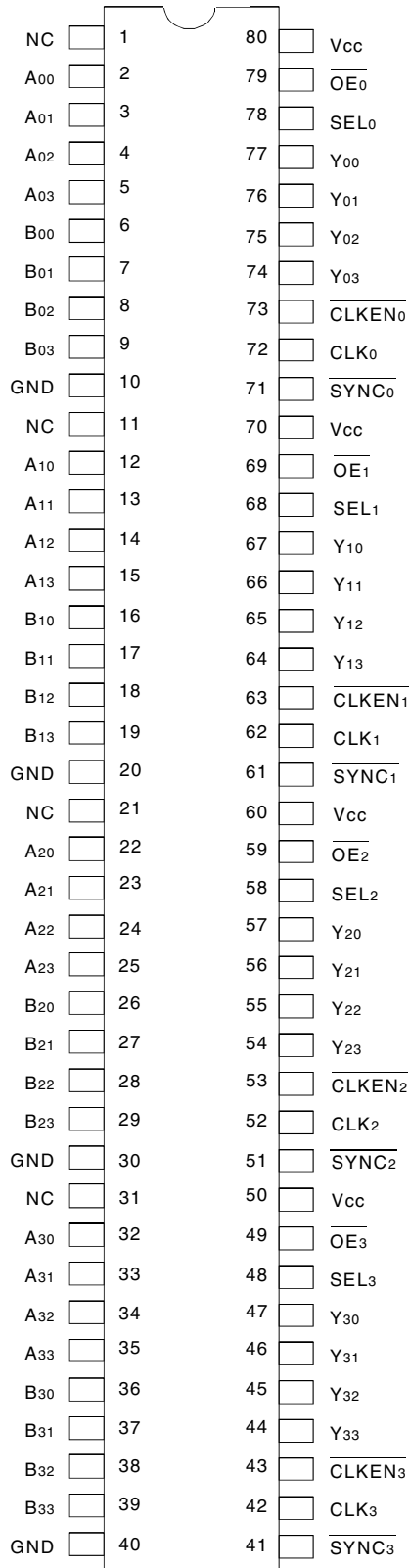

MILLIPAQ (Q3)
TOP VIEW

ABSOLUTE MAXIMUM RATINGS⁽¹⁾

Symbol	Description	Max	Unit
VTERM ⁽²⁾	Supply Voltage to Ground	-0.5 to +7	V
VTERM ⁽³⁾	DC Switch Voltage Vs	-0.5 to +7	V
VTERM ⁽³⁾	DC Input Voltage VIN	-0.5 to +7	V
VAC	AC Input Voltage (pulse width ≤ 20ns)	-3	V
IOUT	DC Output Current	120	mA
PMAX	Maximum Power Dissipation (TA = 85°C)	1.16	W
TSTG	Storage Temperature	-65 to +150	°C

NOTE:

1. Stresses greater than those listed under ABSOLUTE MAXIMUM RATINGS may cause permanent damage to the device. This is a stress rating only and functional operation of the device at these or any other conditions above those indicated in the operational sections of this specification is not implied. Exposure to absolute maximum rating conditions for extended periods may affect reliability.
2. Vcc terminals.
3. All terminals except Vcc.

CAPACITANCE

(TA = +25°C, f = 1.0MHz, VIN = 0V, VOUT = 0V)

Pins		Typ.	Max. ⁽¹⁾	Unit
Control Pins		4	5	pF
Quickswitch Channels (Switch OFF)	Demux	5	7	pF
	Mux	7	9	

NOTE:

1. This parameter is measured at characterization but not tested.

PIN DESCRIPTION

Pin Names	I/O	Description
An0 - An3	I/O	Demux Port A
Bn0 - Bn3	I/O	Demux Port B
Yn0 - Yn3	I/O	Mux Port Y
SELn	I	Select Input
CLKn	I	Clock
CLKENn	I	Clock Enable
OEn	I	Output Enable
SYNCn	I	Synchronous Selection Enable

FUNCTION TABLE (1)

Control Inputs					Port Status				Function
SYNC	OE \bar{n}	CLK n	CLKEN \bar{n}	SEL n	Y n_0	Y n_1	Y n_2	Y n_3	
L	L	↑	L	L	A n_0	A n_1	A n_2	A n_3	Select Port A
L	L	↑	L	H	B n_0	B n_1	B n_2	B n_3	Select Port B
L	H	↑	L	X	No change in Mux connection				Switch OFF (2)
L	L	↑	H	X	No change in Mux connection				Hold Previous Mux connection (3) (Switch ON)
L	H	↑	H	X	No change in Mux connection				Switch OFF (4)
H	L	X	X	L	A n_0	A n_1	A n_2	A n_3	Select Port A
H	L	X	X	H	B n_0	B n_1	B n_2	B n_3	Select Port B
H	H	X	X	X	No change in Mux connection				Hold Previous Data (Switch OFF)

NOTES:

- H = HIGH Voltage Level
L = LOW Voltage Level
X = Don't Care
↑ = LOW-to-HIGH Transition
- Mux switches are turned off. The port connection can be changed by the SEL input.
- The contents of the "Mux select register" are unchanged and the previous Mux connection is unchanged. The output (Mux port) data state will depend on the present data state of the input (Demux port).
- The contents of the "Mux select register" are unchanged.

CONTROL LOGIC (1)

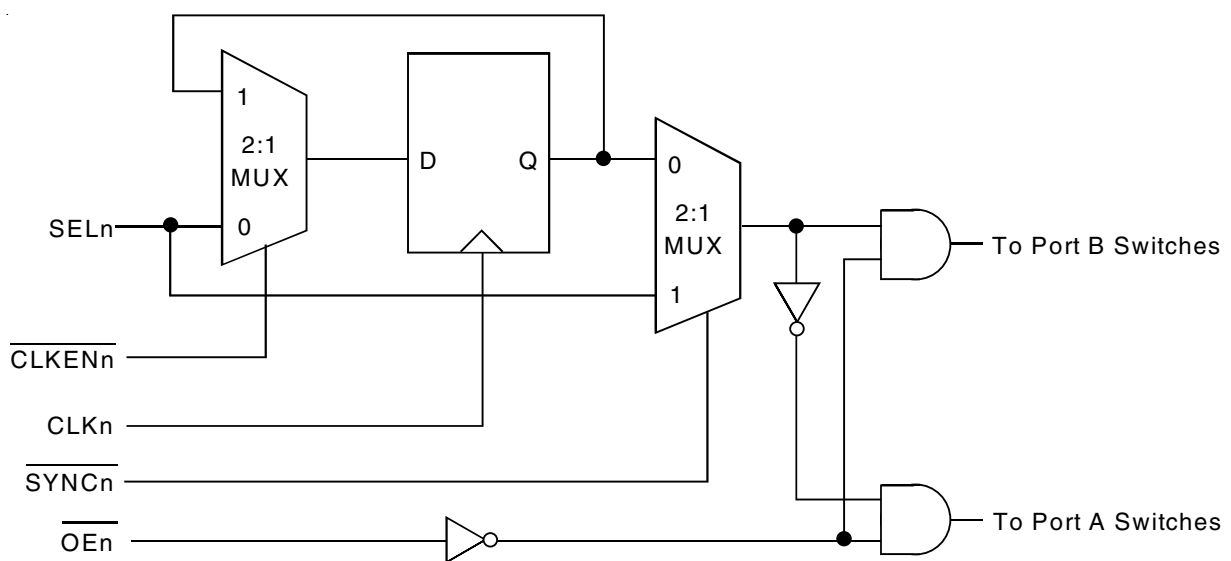

NOTE:

- One of four blocks.

DC ELECTRICAL CHARACTERISTICS OVER OPERATING RANGE

Following Conditions Apply Unless Otherwise Specified:

Industrial: $T_A = -40^{\circ}\text{C}$ to $+85^{\circ}\text{C}$, $V_{CC} = 5.0\text{V} \pm 10\%$

Symbol	Parameter	Test Conditions	Min.	Typ. ⁽¹⁾	Max.	Unit
V_{IH}	Input HIGH Level	Guaranteed Logic HIGH for Control Pins	2	—	—	V
V_{IL}	Input LOW Level	Guaranteed Logic LOW for Control Pins	—	—	0.8	V
I_{IN}	Input Leakage Current (Control Inputs)	$0\text{V} \leq V_{IN} \leq V_{CC}$	—	0.1	± 1	μA
R_{ON}	Switch ON Resistance ^(2,3)	$V_{CC} = \text{Min.}, V_{IN} = 0\text{V}, I_{ON} = 30\text{mA}$	—	7	9	Ω
		$V_{CC} = \text{Min.}, V_{IN} = 2.4\text{V}, I_{ON} = 15\text{mA}$	—	10	13	

NOTES:

1. Typical values are at $V_{CC} = 5.0\text{V}$, $T_A = 25^{\circ}\text{C}$.
2. Max value of R_{ON} is guaranteed but not production tested.
3. Measured by voltage drop between A/B and Y pin at indicated current through the switch.

TYPICAL ON RESISTANCE vs V_{IN} AT $V_{CC} = 5\text{V}$

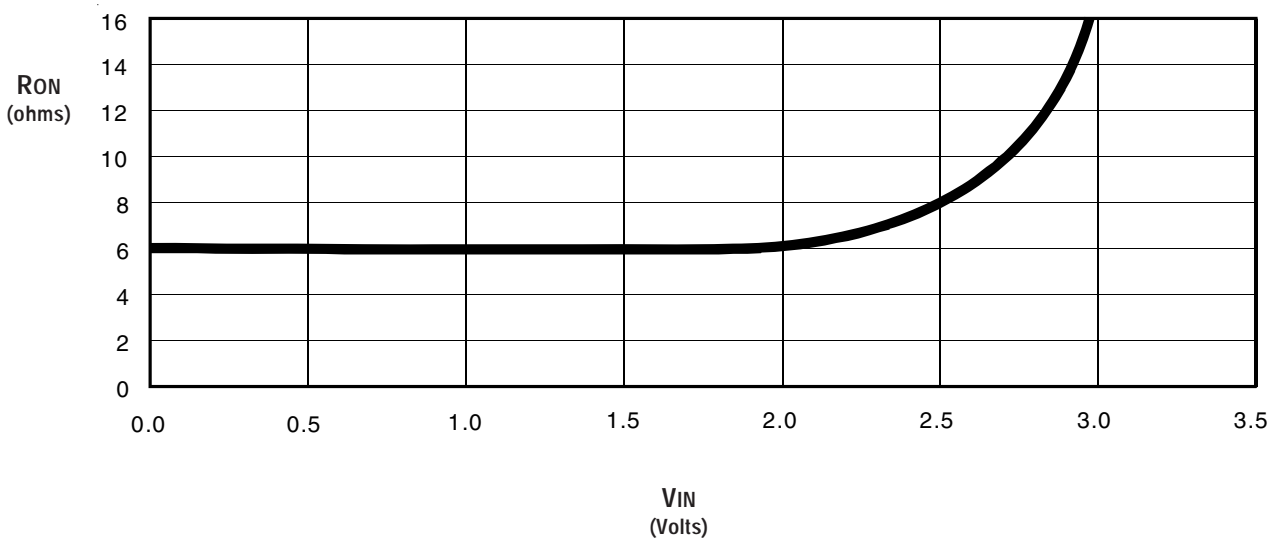

POWER SUPPLY CHARACTERISTICS

Symbol	Parameter	Test Conditions ⁽¹⁾	Max.	Unit
I _{CCQ}	Quiescent Power Supply Current	V _{CC} = Max., V _{CTRL} = GND or V _{CC} , f = 0	12	mA
ΔI _{CC}	Power Supply Current per Control Input HIGH ⁽²⁾	V _{CC} = Max., V _{IN} = 3.4V, f = 0	1.5	mA
I _{CCD}	Dynamic Power Supply Current per MHz ⁽³⁾	V _{CC} = Max., A/B and Y pins open Control Inputs Toggling at 50% Duty Cycle	0.25	mA/MHz

NOTES:

- For conditions shown as Min. or Max., use the appropriate values specified under DC Electrical Characteristics.
- Per TLL driven input (V_{IN} = 3.4V, control inputs only). A/B and Y pins do not contribute to ΔI_{CC}.
- This current applies to the control inputs only and represents the current required to switch internal capacitance at the specified frequency. The A/B and Y inputs generate no significant AC or DC currents as they transition. This parameter is guaranteed but not production tested.

SWITCHING CHARACTERISTICS OVER OPERATING RANGE

T_A = -40°C to +85°C, V_{CC} = 5.0V ± 10%;

C_{LOAD} = 50pF, R_{LOAD} = 500Ω unless otherwise noted.

Symbol	Parameter	Min. ⁽¹⁾	Typ.	Max.	Unit
t _{PLH}	Data Propagation Delay ^(2,3)	—	0.25	—	ns
t _{PHL}	A/B to Y, Y to A/B	—	—	—	ns
t _{SEC}	Clock Enable to Clock Setup Time	3	—	—	ns
t _{HEC}	Clock Enable to Clock Hold Time	0	—	—	ns
t _{CSO}	Clock to A, B Switch Turn-On Delay	0.5	—	7	ns
t _{ASO}	Asynchronous Select to A, B Switch Turn-On Delay	0.5	—	7	ns
t _w	Clock Pulse Width HIGH	3	—	—	ns
t _{SCS}	Clock to SEL Setup Time	3	—	—	ns
t _{HCS}	Clock to SEL Hold Time	0	—	—	ns
t _{PZL}	Asynchronous Enable to Switch Turn-On Delay	1.5	—	5.2	ns
t _{PZH}	Asynchronous Enable to Switch Turn-Off Delay ⁽²⁾	1.5	—	4.8	ns

NOTES:

- Minimums are guaranteed but not production tested.
- This parameter is guaranteed but not production tested.
- The bus switch contributes no propagation delay other than the RC delay of the ON resistance of the switch and the load capacitance. The time constant for the switch alone is of the order of 0.25ns for C_L = 50pF. Since this time constant is much smaller than the rise and fall times of typical driving signals, it adds very little propagation delay to the system. Propagation delay of the bus switch, when used in a system, is determined by the driving circuit on the driving side of the switch and its interaction with the load on the driven side.

TIMING WAVEFORMS - SYNCHRONOUS MODE, DEMUX FUNCTION

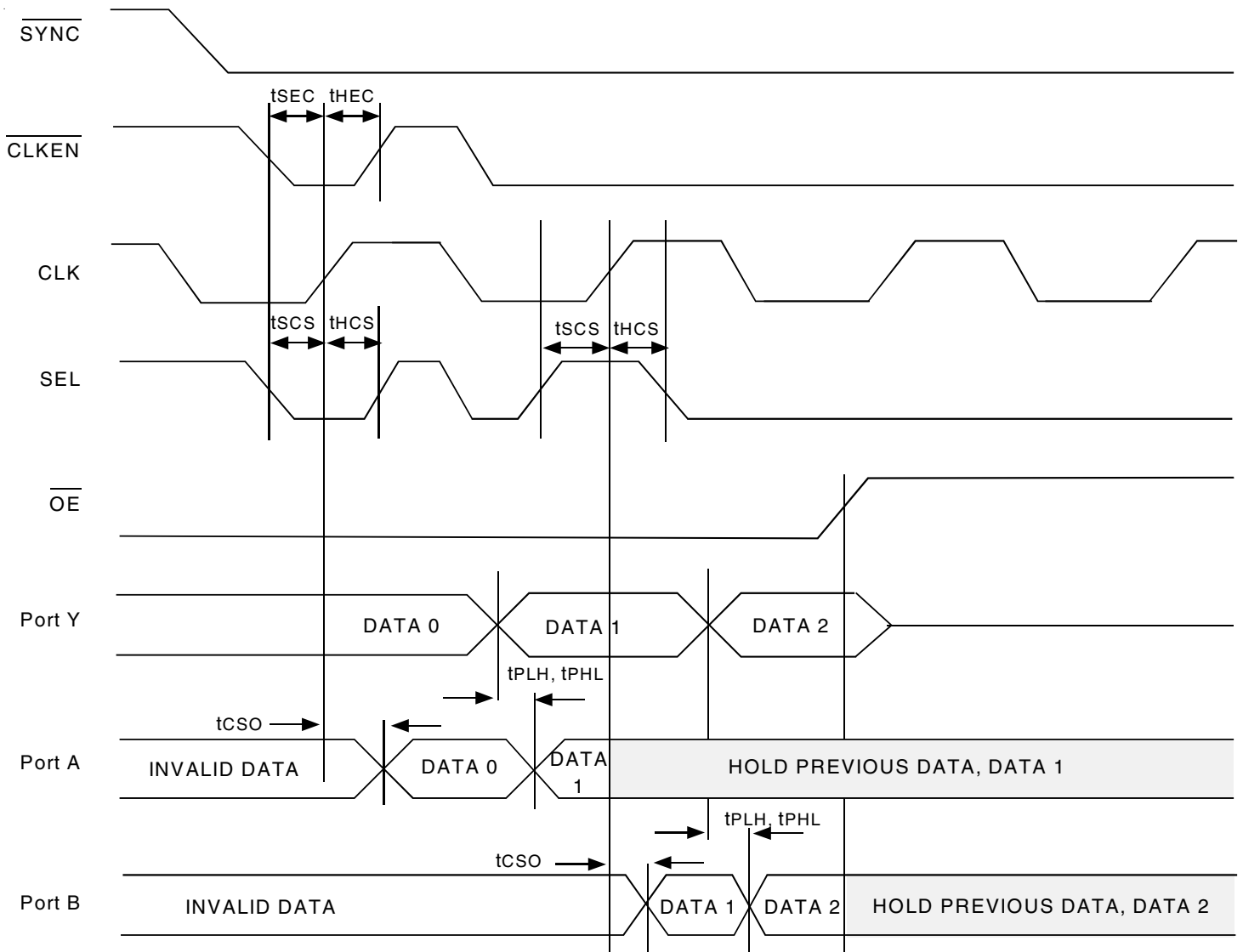

TIMING WAVEFORMS - SYNCHRONOUS MODE, MUX FUNCTION

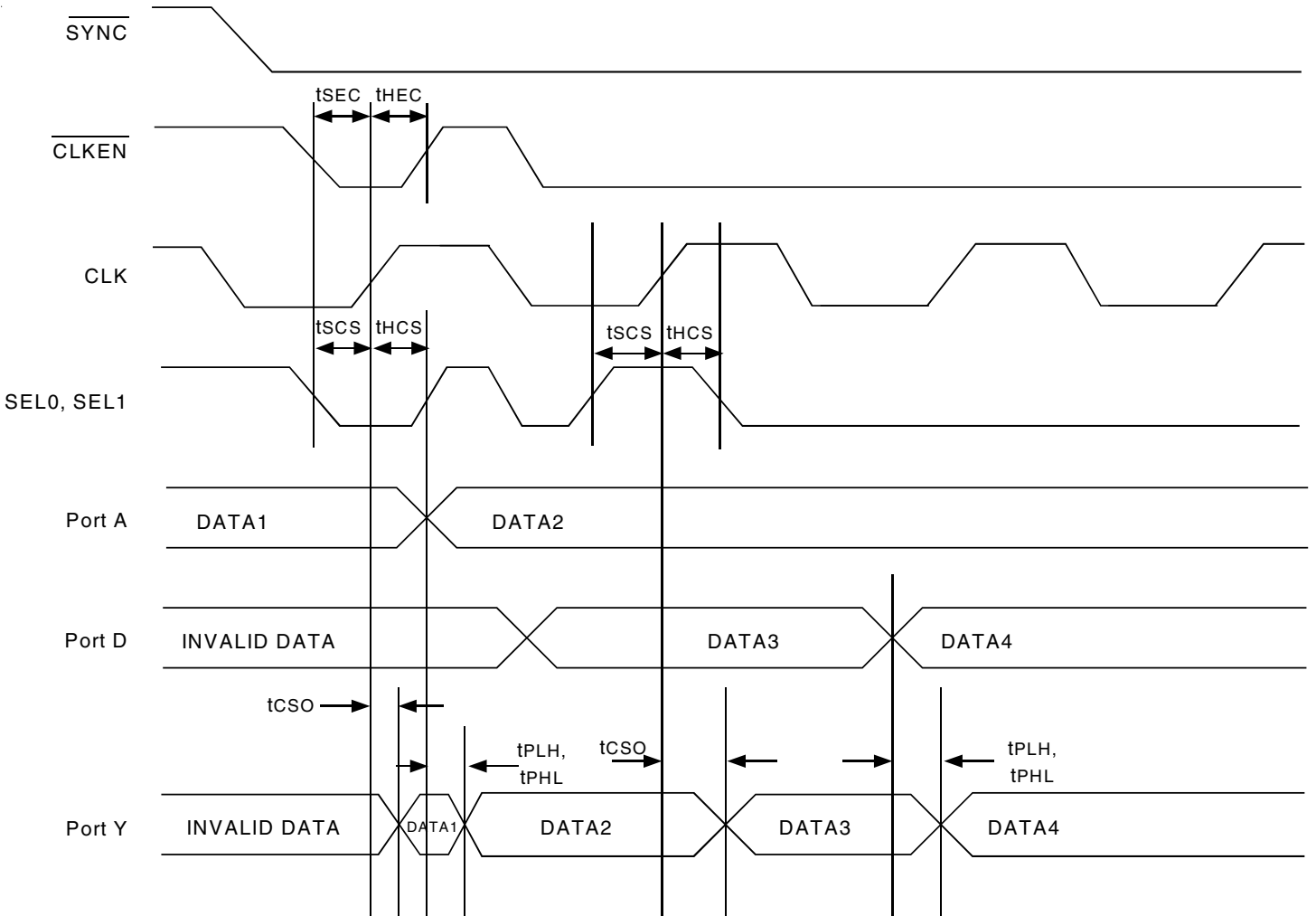

TIMING WAVEFORMS - ASYNCHRONOUS MODE, MUX FUNCTION

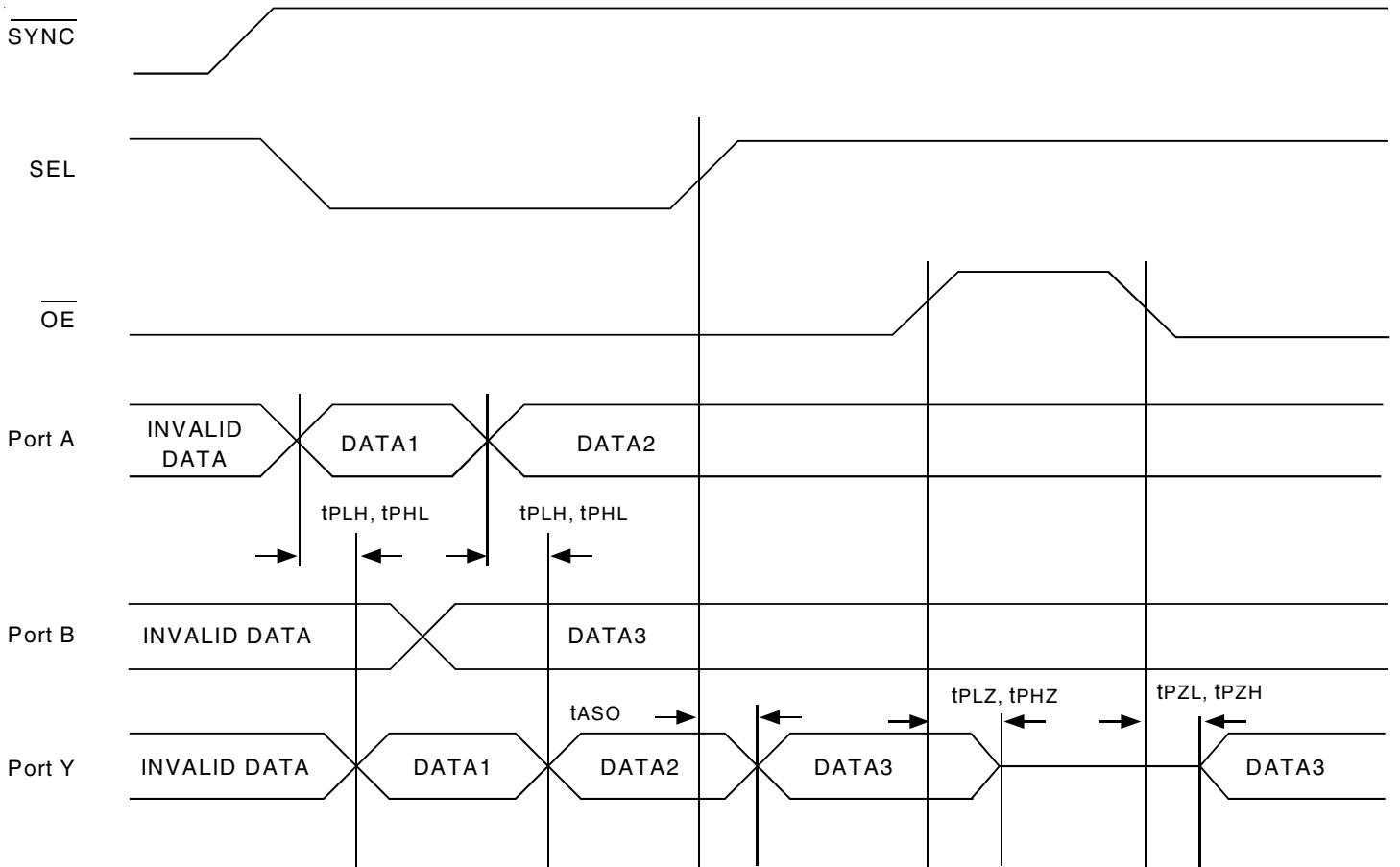

ORDERING INFORMATION

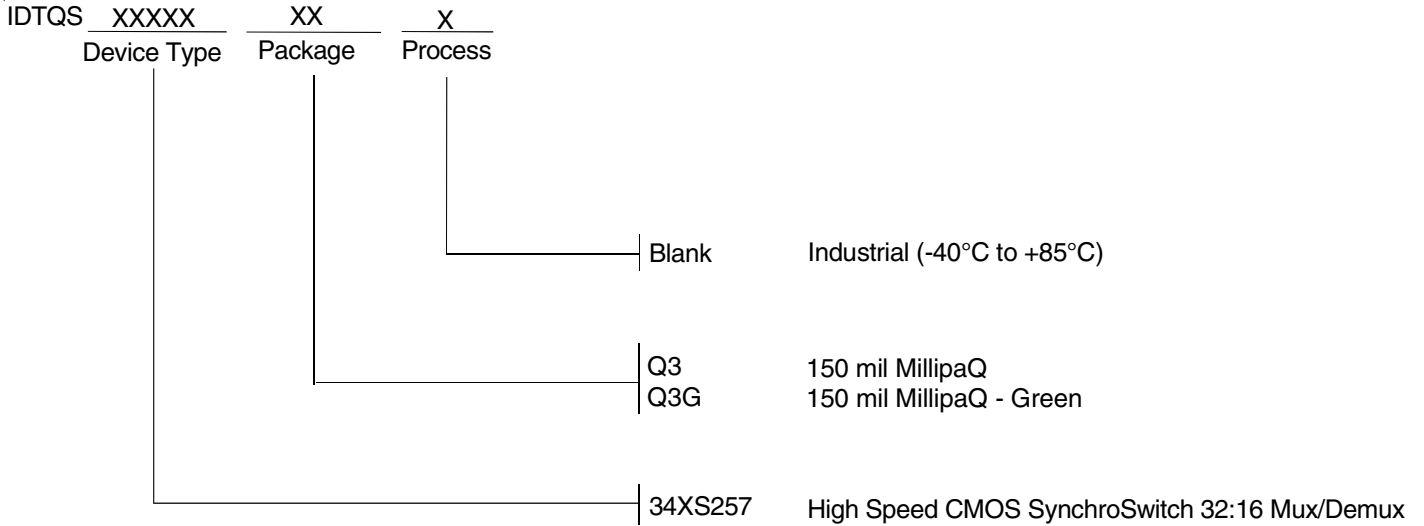

CORPORATE HEADQUARTERS
6024 Silver Creek Valley Road
San Jose, CA 95138

for SALES:
800-345-7015 or 408-284-8200
fax: 408-284-2775
www.idt.com

for Tech Support:
logichelp@idt.com