



8N80

Preliminary

Power MOSFET

800V N-CHANNEL MOSFET

DESCRIPTION

The UTC **8N80** is an N-channel mode Power FET, it uses UTC's advanced technology to provide customers planar stripe and DMOS technology. This technology allows a minimum on-state resistance, superior switching performance. It also can withstand high energy pulse in the avalanche and commutation mode.

The UTC **8N80** is generally applied in high efficiency switch mode power supplies.

FEATURES

- * Typically 35 nC Low Gate Charge
- * 8A, 800V, $R_{DS(on)} = 1.55\Omega @ V_{GS} = 10V$
- * Typically 13 pF Low Crss
- * Improved dv/dt Capability
- * Fast Switching Speed
- * 100% Avalanche Tested
- * RoHS-Compliant Product

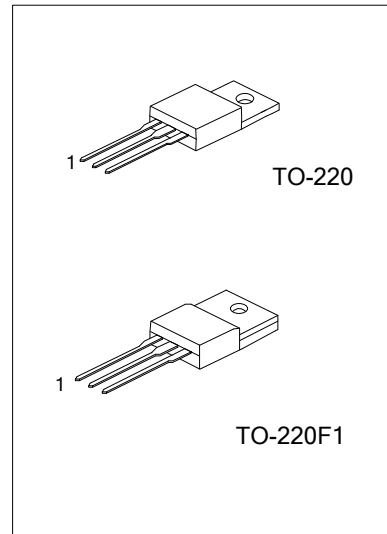

SYMBOL

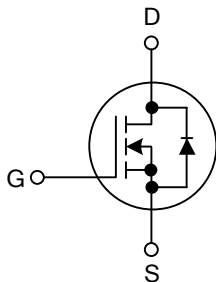

ORDERING INFORMATION

Ordering Number		Package	Pin Assignment			Packing
Lead Free	Halogen Free		1	2	3	
8N80L-TA3-T	8N80G-TA3-T	TO-220	G	D	S	Tube
8N80L-TF1-T	8N80G-TF1-T	TO-220F1	G	D	S	Tube

Note: G: GND, D: Drain, S: Source

<p>8N80G-TA3-T</p> <p>(1)Packing Type</p> <p>(2)Package Type</p> <p>(3)Halogen Free</p>	<p>(1) T: Tube</p> <p>(2) TA3: TO-220, TF1: TO-220F1</p> <p>(3) G: Halogen Free, L: Lead Free</p>
---	---

www.DataSheet4U.com

■ ABSOLUTE MAXIMUM RATINGS ($T_C=25^\circ\text{C}$, unless otherwise specified)

PARAMETER	SYMBOL	RATINGS	UNIT
Drain-Source Voltage	V_{DSS}	800	V
Gate-Source Voltage	V_{GSS}	± 30	V
Drain Current (Continuous) ($T_C=25^\circ\text{C}$)	I_D	8	A
Drain Current (Pulsed) (Note 1)	I_{DM}	32	A
Avalanche Current (Note 1)	I_{AR}	8	A
Single Pulse Avalanche Energy (Note 2)	E_{AS}	850	mJ
Repetitive Avalanche Energy (Note 1)	E_{AR}	17.8	mJ
Peak Diode Recovery dv/dt (Note 3)	dv/dt	4.5	V/ns
Total Power Dissipation ($T_C=25^\circ\text{C}$)	P_D	178	W
Linear Derating Factor above $T_C=25^\circ\text{C}$		1.43	W/ $^\circ\text{C}$
Junction Temperature	T_J	+150	$^\circ\text{C}$
Storage Temperature	T_{STG}	-55~+150	$^\circ\text{C}$

- Note: 1. Repetitive Rating: Pulse width limited by maximum junction temperature
 2. $L = 25\text{mH}$, $I_{AS} = 8\text{A}$, $V_{DD} = 50\text{V}$, $R_G = 25\ \Omega$, Starting $T_J = 25^\circ\text{C}$
 3. $I_{SD} \leq 8\text{A}$, $di/dt \leq 200\text{A}/\mu\text{s}$, $V_{DD} \leq BV_{DSS}$, Starting $T_J = 25^\circ\text{C}$
 4. Absolute maximum ratings are those values beyond which the device could be permanently damaged.
 Absolute maximum ratings are stress ratings only and functional device operation is not implied

■ THERMAL DATA

PARAMETER	SYMBOL	RATINGS	UNIT
Junction to Ambient	θ_{JA}	62.5	$^\circ\text{C}/\text{W}$
Junction to Case	θ_{JC}	0.7	$^\circ\text{C}/\text{W}$

■ ELECTRICAL CHARACTERISTICS ($T_C=25^\circ\text{C}$, unless otherwise specified)

PARAMETER	SYMBOL	TEST CONDITIONS	MIN	TYP	MAX	UNIT
OFF CHARACTERISTICS						
Drain-Source Breakdown Voltage	BV_{DSS}	$I_D=250\mu\text{A}$, $V_{GS}=0\text{V}$	800			V
Breakdown Voltage Temperature Coefficient	$\Delta BV_{DSS}/\Delta T_J$	Reference to 25°C , $I_D=250\mu\text{A}$		0.5		$\text{V}/^\circ\text{C}$
Drain-Source Leakage Current	I_{DSS}	$V_{DS}=800\text{V}$, $V_{GS}=0\text{V}$ $V_{DS}=640\text{V}$, $T_C=125^\circ\text{C}$			10 100	μA
Gate- Source Leakage Current	I_{GSS}	$V_{GS}=\pm 30\text{V}$, $V_{DS}=0\text{V}$			± 100	nA
ON CHARACTERISTICS						
Gate Threshold Voltage	$V_{GS(TH)}$	$V_{DS}=V_{GS}$, $I_D=250\mu\text{A}$	3.0		5.0	V
Static Drain-Source On-State Resistance	$R_{DS(ON)}$	$V_{GS}=10\text{V}$, $I_D=4\text{A}$		0.94	1.55	Ω
Forward Transconductance (Note 1)	g_{FS}	$V_{DS}=50\text{V}$, $I_D=4\text{A}$		5.6		S
DYNAMIC PARAMETERS						
Input Capacitance	C_{ISS}	$V_{GS}=0\text{V}$, $V_{DS}=25\text{V}$, $f=1.0\text{MHz}$		1580	2050	pF
Output Capacitance	C_{OSS}			135	175	pF
Reverse Transfer Capacitance	C_{RSS}			13	17	pF
SWITCHING PARAMETERS (Note 1, Note 2)						
Total Gate Charge	Q_G	$V_{GS}=10\text{V}$, $V_{DS}=640\text{V}$, $I_D=8\text{A}$		35	45	nC
Gate to Source Charge	Q_{GS}			10		nC
Gate to Drain Charge	Q_{GD}			14		nC
Turn-ON Delay Time	$t_{D(ON)}$	$V_{DD}=400\text{V}$, $I_D=8\text{A}$, $R_G=25\ \Omega$		40	90	ns
Rise Time	t_R			110	230	ns
Turn-OFF Delay Time	$t_{D(OFF)}$			65	140	ns
Fall-Time	t_F			70	150	ns
SOURCE- DRAIN DIODE RATINGS AND CHARACTERISTICS						
Maximum Continuous Drain-Source Diode Forward Current	I_S				8	A
Maximum Pulsed Drain-Source Diode Forward Current	I_{SM}				32	A
Drain-Source Diode Forward Voltage	V_{SD}	$I_S=8\text{A}$, $V_{GS}=0\text{V}$			1.4	V
Reverse Recovery Time (Note 1)	t_{RR}	$I_S=8\text{A}$, $V_{GS}=0\text{V}$, $di_F/dt=100\text{A}/\mu\text{s}$		690		ns
Reverse Recovery Charge (Note 1)	Q_{RR}				8.2	

- Note: 1. Pulse Test: Pulse width $\leq 300\mu\text{s}$, Duty cycle $\leq 2\%$
 2. Essentially independent of operating temperature

■ TEST CIRCUITS AND WAVEFORMS

Peak Diode Recovery dv/dt Test Circuit & Waveforms

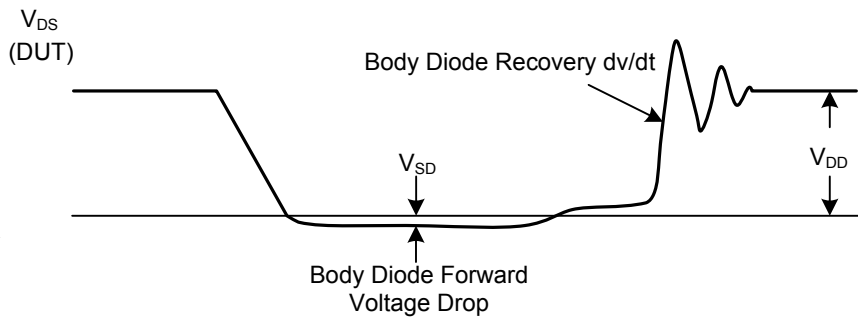
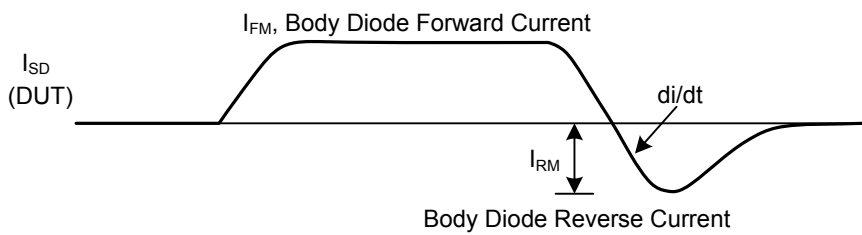
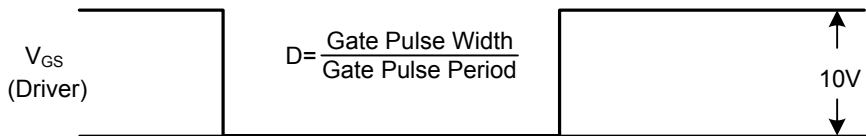
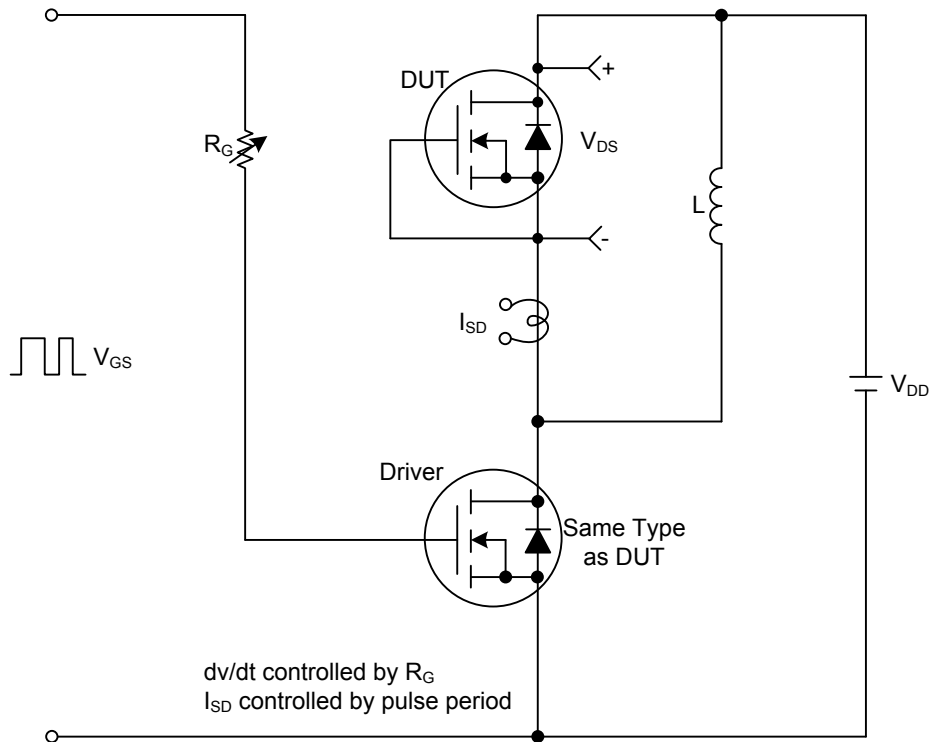

www.DataSheet4U.com

■ TEST CIRCUITS AND WAVEFORMS

Gate Charge Test Circuit

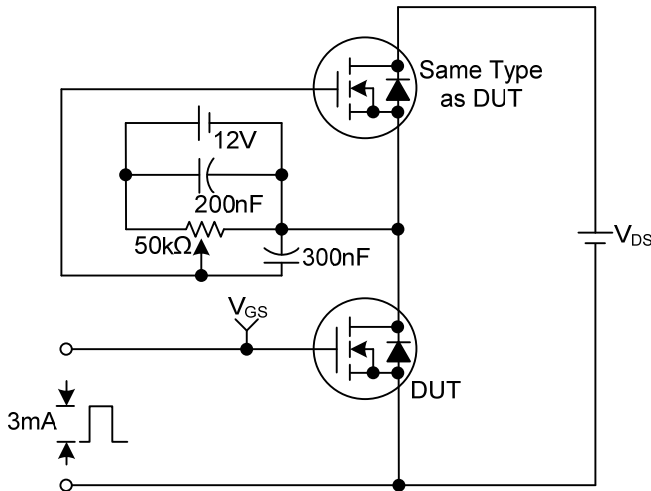

Gate Charge Waveforms

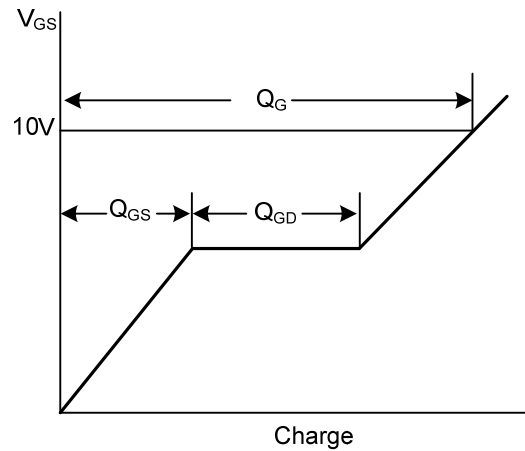

Resistive Switching Test Circuit

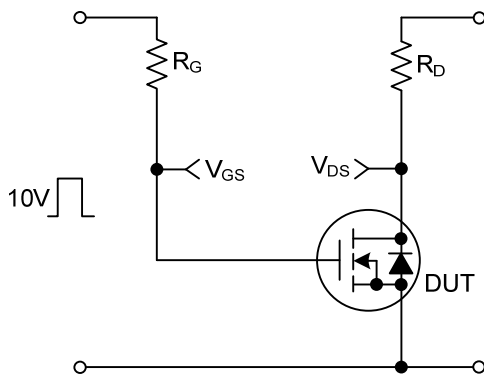

Resistive Switching Waveforms

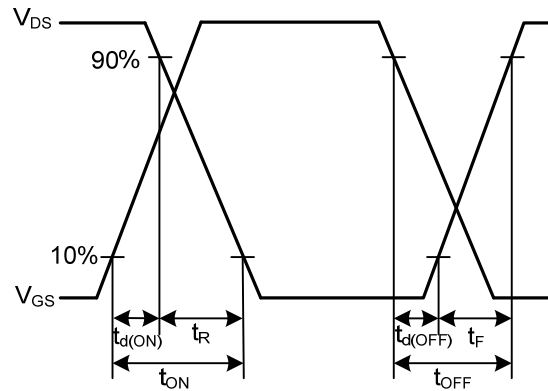

Unclamped Inductive Switching Test Circuit

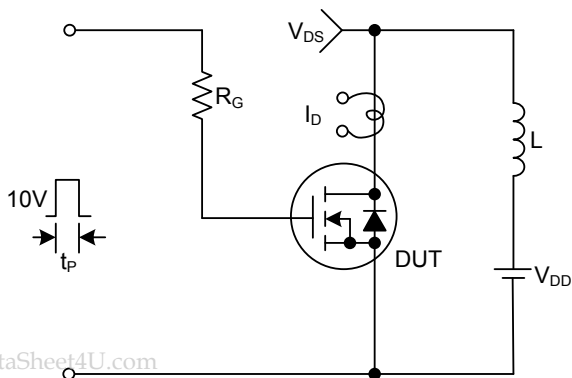

Unclamped Inductive Switching Waveforms

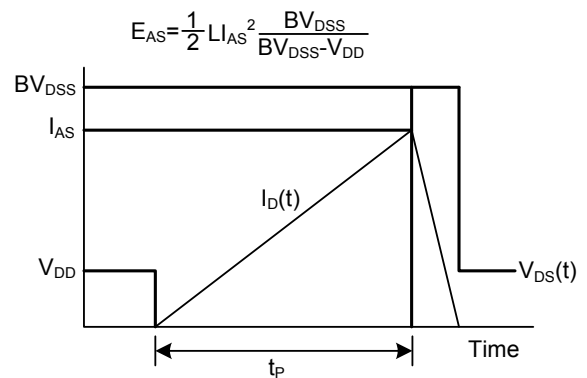

www.DataSheet4U.com

UTC assumes no responsibility for equipment failures that result from using products at values that exceed, even momentarily, rated values (such as maximum ratings, operating condition ranges, or other parameters) listed in products specifications of any and all UTC products described or contained herein. UTC products are not designed for use in life support appliances, devices or systems where malfunction of these products can be reasonably expected to result in personal injury. Reproduction in whole or in part is prohibited without the prior written consent of the copyright owner. The information presented in this document does not form part of any quotation or contract, is believed to be accurate and reliable and may be changed without notice.