

isc Silicon PNP Darlington Power Transistor

MJE703T

DESCRIPTION

- Collector–Emitter Breakdown Voltage—
: $V_{(BR)CEO} = -80\text{ V}$
- DC Current Gain—
: $h_{FE} = 750(\text{Min}) @ I_C = -2\text{A}$
- Complement to Type MJE803T

APPLICATIONS

- Designed for general-purpose amplifier and low-speed switching applications

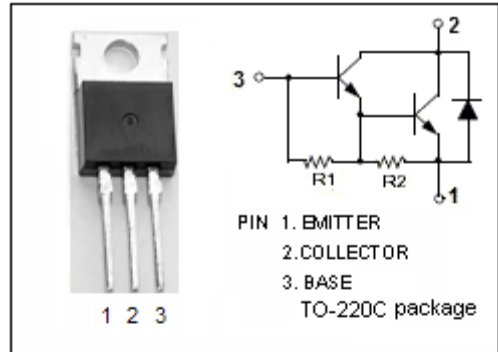

ABSOLUTE MAXIMUM RATINGS($T_a=25^\circ\text{C}$)

SYMBOL	PARAMETER	VALUE	UNIT
V_{CBO}	Collector-Base Voltage	-80	V
V_{CEO}	Collector-Emitter Voltage	-80	V
V_{EBO}	Emitter-Base Voltage	-5	V
I_C	Collector Current-Continuous	-4	A
I_B	Base Current	-0.1	A
P_C	Collector Power Dissipation $T_C=25^\circ\text{C}$	50	W
T_j	Junction Temperature	150	$^\circ\text{C}$
T_{stg}	Storage Temperature Range	-55~150	$^\circ\text{C}$

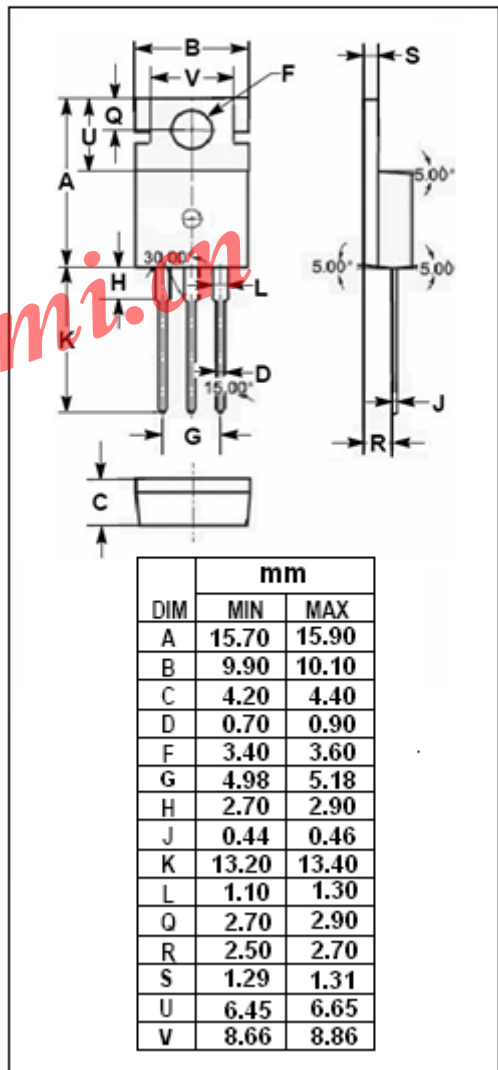

THERMAL CHARACTERISTICS

SYMBOL	PARAMETER	MAX	UNIT
$R_{th\ j-c}$	Thermal Resistance, Junction to Case	2.5	$^\circ\text{C/W}$

isc Silicon PNP Darlington Power Transistor

MJE703T

ELECTRICAL CHARACTERISTICS

 $T_C=25^{\circ}\text{C}$ unless otherwise specified

SYMBOL	PARAMETER	CONDITIONS	MIN	MAX	UNIT
$V_{(BR)CEO}$	Collector-Emitter Breakdown Voltage	$I_C=-50\text{mA}; I_B=0$	-80		V
$V_{CE(sat)-1}$	Collector-Emitter Saturation Voltage	$I_C=-2\text{A}; I_B=-40\text{mA}$		-2.8	V
$V_{CE(sat)-2}$	Collector-Emitter Saturation Voltage	$I_C=-4\text{A}; I_B=-40\text{mA}$		-3.0	V
$V_{BE(on)-1}$	Base-Emitter On Voltage	$I_C=-2\text{A}; V_{CE}=-3\text{V}$		-2.5	V
$V_{BE(on)-2}$	Base-Emitter On Voltage	$I_C=-4\text{A}; V_{CE}=-3\text{V}$		-3.0	V
I_{CEO}	Collector Cutoff Current	$V_{CE}=-80\text{V}; I_B=0$		-0.1	mA
I_{CBO}	Collector Cutoff Current	$V_{CB}=-80\text{V}; I_E=0$ $V_{CB}=-80\text{V}; I_E=0; T_C=100^{\circ}\text{C}$		-0.1 -0.5	mA
I_{EBO}	Emitter Cutoff Current	$V_{EB}=-5\text{V}; I_C=0$		2.0	mA
h_{FE-1}	DC Current Gain	$I_C=-2\text{A}; V_{CE}=-3\text{V}$	750		
h_{FE-2}	DC Current Gain	$I_C=-4\text{A}; V_{CE}=-3\text{V}$	100		