

Helping Customers Innovate, Improve & Grow



The MD010 is a Vectron standard platform module that provides 1 pps TTL, 10 MHz sine wave and 10 MHz square wave outputs that are disciplined to an external 1 pps reference. Internal to the module is a Vectron oscillator, ranging from a TCXO to a double oven OCXO, dependent upon performance requirements. Internal oscillators are capable of achieving an aging rate less as high as than 0.1ppb/day and stability over the operating temperature range of less than 0.2ppb. In addition to the 7 standard models included in this data sheet, due to Vectron's extensive portfolio of oscillators and a firmware driven architecture, Vectron can customize a solution for your specific application.

## Features

- 1 pps TTL output signals standard
- 10MHz sinewave and square wave outputs standard
- Other output frequencies available
- Embedded oscillator dependent upon holdover requirements
- Serial communications interface standard

## Applications

- 3G Basestations (WCDMA, CDMA2000)
- LTE
- WiMAX Basestations
- Digital Video Broadcast
- E911 Location Systems
- General Timing and Synchronization
- Military Radio

## Block Diagram

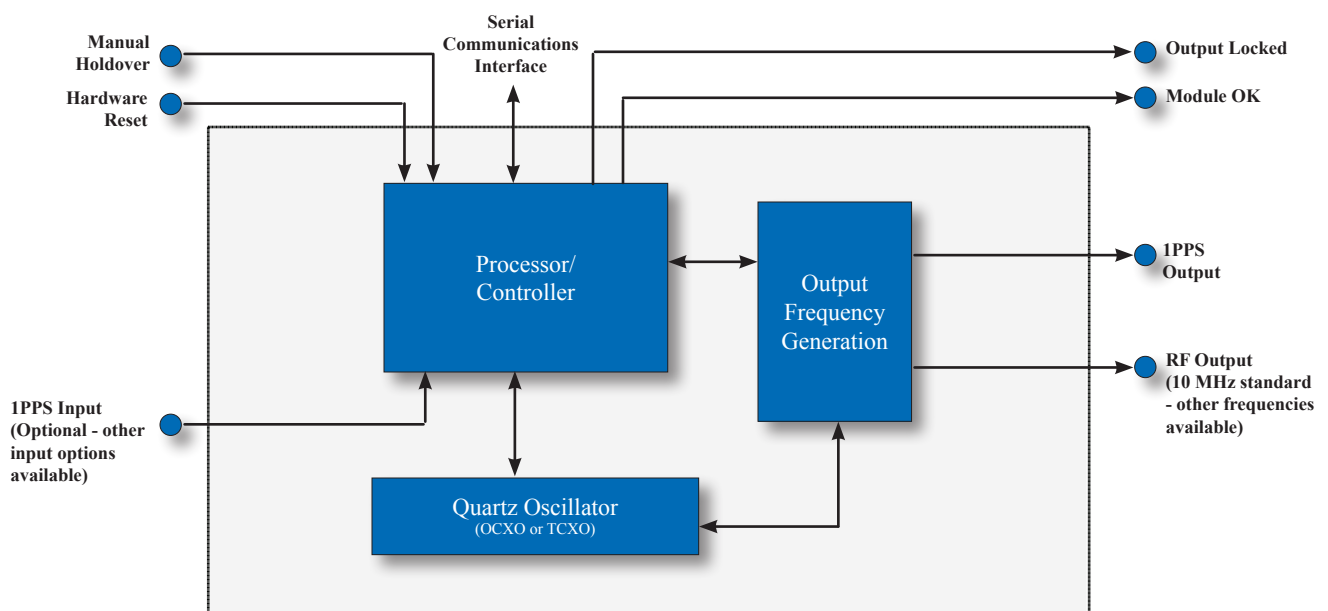

Figure 1. Functional Block Diagram

## Summary Specifications

Comparitive Performance of Standard Modules									
Model	Embedded Oscillator	Typical Uses							
MD-0100-DXJ-TCXO-10M0000000	TCXO	Applications requiring a disciplined clock with little or no hold over							
MD-0102-DXJ-HPTC-10M0000000	High Precision TCXO	Applications requiring 1 hour hold over on the order of 10 us							
MD-0101-DXJ-EMXO-10M0000000	EMXO	Applications requiring 8 hour hold over on the order of 100 us							
MD-0101-DXJ-DAEM-10M0000000	Digitally Assisted EMXO	Application requiring 8 hour hold over of 100us over extended temperature ranges							
MD-0103-BXJ-OCXO-10M0000000	OCXO	Applications requiring 8 hour hold over of 50 us over extended temperature ranges							
MD-0103-BXJ-DAOC-10M0000000	Digitally Assisted OCXO	Applications requiring 24 hour hold over on the order of 20 us							
MD-0104-BXJ-DOCX-10M0000000	Double Oven OCXO	Applications with stringent hold over requirements, 8.6 us over 24 hour							
Hold Over Performance (detailed performance on page 5) <sup>1</sup>									
Hold Over Time	10 min	1 hr	1 hr	8 hr	8 hr	24hr	24 hr		
Hold Over Temperature Change	$\Delta T = 2\text{ }^{\circ}\text{C}$	$\Delta T = 2\text{ }^{\circ}\text{C}$	$\Delta T = 10\text{ }^{\circ}\text{C}$	$\Delta T = 2\text{ }^{\circ}\text{C}$	$\Delta T = 10\text{ }^{\circ}\text{C}$	$\Delta T = 2\text{ }^{\circ}\text{C}$	$\Delta T = 10\text{ }^{\circ}\text{C}$		
Model	Maximum Accumulated Hold Over in us								
MD-0100-DXJ-TCXO-10M0000000	4.9	32	120	500	1200	2400	4700		
MD-0102-DXJ-HPTC-10M0000000	1.5	12	27	270	380	2000	2400		
MD-0101-DXJ-EMXO-10M0000000	2.5	12.5	60	105	490	340	1500		
MD-0101-DXJ-DAEM-10M0000000	0.4	2	8.7	20	75	90	250		
MD-0103-BXJ-OCXO-10M0000000	0.14	0.9	4	9	30	35	100		
MD-0103-BXJ-DAOC-10M0000000	0.05	0.24	0.4	2.8	3.7	18	21		
MD-0104-BXJ-DOCX-10M0000000	0.05	0.09	.21	1	2.5	5.9	10		
Summary Performance Characteristics									
Model	Warm Up Time (min-utes)	Aging / day (ppb) <sup>1</sup>	Temperature Stability (ppb) <sup>2</sup>	Module Height (mm)	Accuracy to UTC (+/-1sigma)	Accuracy (+/-) <sup>3</sup>	Warm up Power @ 25 °C (W)	Steady State Power @ 25 °C (W)	Voltage (V)
MD-0100-DXJ-TCXO-10M0000000	5	40	280	11	100 ns	5E-12	0.3	0.3	5
MD-0102-DXJ-HPTC-10M0000000	5	40	50	12.6	100 ns	5E-12	0.35	0.3	5
MD-0101-DXJ-EMXO-10M0000000	10	1	75	11.8	50 ns	2E-12	1.75	0.6	5
MD-0101-DXJ-DAEM-10M0000000	10	1	10	11.8	50 ns	2E-12	1.75	0.6	5
MD-0103-BXJ-OCXO-10M0000000	18	0.2	4	19.5	50 ns	1E-12	4.2	3	12
MD-0103-BXJ-DAOC-10M0000000	18	0.2	0.2	19.5	50 ns	1E-12	4.2	3	12
MD-0104-BXJ-DOCX-10M0000000	18	0.1	0.2	21.3	50 ns	1E-12	14	5.3	12
Phase Noise/ AVAR									
	-10 Hz	-100 Hz	-1 kHz	-10 kHz	-100 kHz	AVAR ( $\tau=1s$ )	AVAR ( $\tau=10s$ )		
MD-0100-DXJ-TCXO-10M0000000	-95	-120	-140	-155	-155	tbd	tbd		
MD-0102-DXJ-HPTC-10M0000000	-80	-110	-130	-140	-150	tbd	tbd		
MD-0101-DXJ-EMXO-10M0000000	-100	-130	-140	-145	-150	1E-10	5E-10		
MD-0101-DXJ-DAEM-10M0000000	-100	-130	-140	-145	-150	1E-10	5E-10		
MD-0103-BXJ-OCXO-10M0000000	-120	-135	-145	-145	-145	1E-11	2E-11		
MD-0103-BXJ-DAOC-10M0000000	-120	-135	-145	-145	-145	1E-11	2E-11		
MD-0104-BXJ-DOCX-10M0000000	-120	-135	-145	-145	-145	1E-11	2E-11		

## Specifications

RF Output Waveform Characteristics (via sma)					
Parameter	Min	Typical	Max	Units	Condition
Waveform	Sinewave				
Output Power	+3.0	+9.0	+11.0	dBm	50 Ohm, 12 V supply models
	+2.0	+5.0	+7.5	dBm	50 Ohm, 5 V supply models
Harmonics			-30	dBc	50 Ohm
Spurious			-70	dBc	50 Ohm
RF Output Waveform Characteristics (via pin 8)					
Waveform	HCMOS				
High Level Output Voltage ( $V_{OH}$ )	4.5		5.0	$V_{DC}$	<-0.5mA Load, 12 V supply models
	3.0		3.3	$V_{DC}$	<-0.5mA Load, 5 V supply models
Low Level Output Voltage ( $V_{OL}$ )		0.0	0.4	$V_{DC}$	<0.5mA Load, 12 V supply models
		0.0	0.3	$V_{DC}$	<0.5mA Load, 5 V supply models
Rise/Fall Time		3	5	nSec	15 pF
Duty Cycle	40	50	60	%	15 pF
1pps Output Characteristics (via SMA and pin 2)					
Parameter	Min	Typical	Max	Units	Condition
Waveform	TTL				
High-level output voltage ( $V_{OH}$ )	4.0		5.0	$V_{DC}$	50 Ohms, 12 V supply models
	2.3		3.3	$V_{DC}$	50 Ohms, 5V supply models
Low-level output voltage ( $V_{OL}$ )		0.0	0.4	$V_{DC}$	50 Ohms, 12 V supply models
		0.0	0.3	$V_{DC}$	50 Ohms, 5V supply models
Pulse Width		10		us	default value user programmable 100 ns to 999.9999 ms
External 1PPS Reference Input (Pin 1)					
Waveform	TTL				
High-Level Output Voltage ( $V_{OH}$ )	2.4		5.0	$V_{DC}$	50 Ohms input impedance
Low-Level Output Voltage ( $V_{OL}$ )		0.0	0.4	$V_{DC}$	
Pulse width <sup>7</sup>	10			uSec	
Lock Status Indicator (Pin 9) <sup>4</sup>					
Parameter	Min	Typical	Max	Units	Condition
Module Locked	4.5		5.0	$V_{DC}$	<5mA Load, 12 V supply model
	3.0		3.3	$V_{DC}$	<5mA Load, 5V supply model
Module Not Locked	0		0.5	$V_{DC}$	<5mA Load, 12 V Supply model
	0		0.3	$V_{DC}$	<5mA Load, 5V supply model
Module Hardware OK Indicator (Pin 10) <sup>5</sup>					
Module Hardware OK	4.5		5.0	$V_{DC}$	<5mA Load, 12 V supply model
	3.0		3.3	$V_{DC}$	<5mA Load, 5V supply model
Module Hardware Failure	0		0.5	$V_{DC}$	<5mA Load, 12 V Supply model
	0		0.3	$V_{DC}$	<5mA Load, 5V supply model

## Specifications

Module Hardware Reset (Pin 12) <sup>6</sup>					
Reset Module			0.5	V <sub>DC</sub>	2 kOhm internal pull up resistance
			0.3	V <sub>DC</sub>	2 kOhm internal pull up resistance
Manual Holdover Set (Pin 11) <sup>7</sup>					
Enter Manual Holdover	0		0.5	V <sub>DC</sub>	2 kOhm internal pull up resistance
	0		0.3	V <sub>DC</sub>	2 kOhm internal pull up resistance
Serial Communications Interface <sup>8</sup>					
Rx high-level input voltage (V <sub>IH</sub> )	4.5		5.5	V <sub>DC</sub>	12 V supply model
	3.0		3.3	V <sub>DC</sub>	5 V supply model
Rx low-level input voltage (V <sub>IL</sub> )	-0.5	0.0	0.5	V <sub>DC</sub>	12 V supply model
	-0.3	0.0	0.3	V <sub>DC</sub>	5 V supply model
Tx high-level output voltage (V <sub>OH</sub> )	4.5	5.0		V <sub>DC</sub>	12 V supply model
	3.0	3.3		V <sub>DC</sub>	5 V supply model
Tx low-level output voltage (V <sub>OL</sub> )	-0.5	0.0	0.5	V <sub>DC</sub>	12 V supply model
	-0.3	0.0	0.3	V <sub>DC</sub>	5 V supply model
Update rate		1		Hz	User configurable from 0 to 255 seconds
Communications Protocol	Vectron Binary/NMEA 0183				See MD-010/MD-010 Command List for Full Details
Pulse width <sup>7</sup>	10			uSec	
Supply Voltage (Pin 7,15,16)					
Supply voltage	+11.4	+12	+12.6	V <sub>DC</sub>	12 V supply models
	+4.75	+5	+5.25	V <sub>DC</sub>	5 V supply models
Absolute Maximum Ratings					
Supply voltage (V <sub>S</sub> )			15	V <sub>DC</sub>	12 V supply models
			7.5	V <sub>DC</sub>	5 V supply models
Dc voltage on any I/O pin			5.5	V	
Output load	10			Ohms	
AC ripple			50	mVpk-pk	10Hz to 1MHz

## Detailed Hold Over Specifications (us)

Holdover Capability - MD-0100-DXJ-TCXO-10M0000000					
Holdover Time	$\Delta T=2\text{ }^{\circ}\text{C}$	$\Delta T=10\text{ }^{\circ}\text{C}$	$\Delta T=20\text{ }^{\circ}\text{C}$	$\Delta T=30\text{ }^{\circ}\text{C}$	$\Delta T=45\text{ }^{\circ}\text{C}^9$
1 minute	0.6	2.1	4	6	10
5 minutes	2	10	20	30	45
10 minutes	4.9	20	40	60	85
30 minutes	15	60	120	175	260
1 hour	32	120	240	350	520
Holdover Capability - MD-0102-DXJ-HPTC-10M0000000					
Holdover Time	$\Delta T=2\text{ }^{\circ}\text{C}$	$\Delta T=10\text{ }^{\circ}\text{C}$	$\Delta T=20\text{ }^{\circ}\text{C}$	$\Delta T=30\text{ }^{\circ}\text{C}$	$\Delta T=45\text{ }^{\circ}\text{C}^9$
1 minute	0.25	0.5	1	1.2	1.7
5 minutes	0.75	2.1	4	5.5	8
10 minutes	1.5	4.3	8	10.8	16
30 minutes	4.8	13	23	33	55
1 hour	12	27	47	66	120
Holdover Capability - MD-0101-DXJ-EMXO-10M0000000					
Holdover Time	$\Delta T=2\text{ }^{\circ}\text{C}$	$\Delta T=10\text{ }^{\circ}\text{C}$	$\Delta T=20\text{ }^{\circ}\text{C}$	$\Delta T=30\text{ }^{\circ}\text{C}$	$\Delta T=45\text{ }^{\circ}\text{C}^9$
30 minutes	6.5	31	60	95	140
1 hour	12.5	60	120	180	270
4 hours	52	250	480	725	1090
8 hours	105	490	970	1450	2170
24 hours	340	1500	2950	4380	6530
Holdover Capability - MD-0101-DXJ-DAEM-10M0000000					
Holdover Time	$\Delta T=2\text{ }^{\circ}\text{C}$	$\Delta T=10\text{ }^{\circ}\text{C}$	$\Delta T=20\text{ }^{\circ}\text{C}$	$\Delta T=30\text{ }^{\circ}\text{C}$	$\Delta T=45\text{ }^{\circ}\text{C}^9$
30 minutes	1	4.5	8.2	12.3	19
1 hour	2	8.7	17	25	37
4 hours	8.5	34	70	100	150
8 hours	20	75	140	200	295
24 hours	90	240	440	630	920
Holdover Capability - MD-0103-BXJ-OCXO-10M0000000					
Holdover Time	$\Delta T=2\text{ }^{\circ}\text{C}$	$\Delta T=10\text{ }^{\circ}\text{C}$	$\Delta T=20\text{ }^{\circ}\text{C}$	$\Delta T=30\text{ }^{\circ}\text{C}$	$\Delta T=45\text{ }^{\circ}\text{C}^9$
30 minutes	0.45	1.8	3.4	5	7.4
1 hour	0.9	4	6.6	10	15
4 hours	3.6	14	27	40	60
8 hours	8	30	55	80	120
24 hours	32	100	170	250	360
Holdover Capability - MD-0103-BXJ-DAOC-10M0000000					
Holdover Time	$\Delta T=2\text{ }^{\circ}\text{C}$	$\Delta T=10\text{ }^{\circ}\text{C}$	$\Delta T=20\text{ }^{\circ}\text{C}$	$\Delta T=30\text{ }^{\circ}\text{C}$	$\Delta T=45\text{ }^{\circ}\text{C}^9$
30 minutes	0.12	0.2	0.3	0.35	0.5
1 hour	.24	0.4	0.5	1	1
4 hours	1	1.6	2.3	3	3.9
8 hours	2.8	3.7	5	6.4	8.2
24 hours	18	21	23	25	32
Holdover Capability - MD-0104-BXJ-DOCX-10M0000000					
Holdover Time	$\Delta T=2\text{ }^{\circ}\text{C}$	$\Delta T=10\text{ }^{\circ}\text{C}$	$\Delta T=20\text{ }^{\circ}\text{C}$	$\Delta T=30\text{ }^{\circ}\text{C}$	$\Delta T=45\text{ }^{\circ}\text{C}^9$
30 minutes	0.05	0.11	0.19	0.27	0.4
1 hour	.09	0.21	0.38	0.54	0.77
4 hours	0.4	0.91	1.54	2.2	3.1
8 hours	1.03	2	3.4	4.7	6.8
24 hours	5.9	9	12.8	17	23

## Specifications

### Environmental Conditions

Parameter	Min	Typical	Max	Units	Condition
Operating temperature	see ordering information for available ranges				
Humidity @ 40°C			90	%	
Storage Temperature	-55		+125	°C	

## Reliability

VI qualification includes aging various extreme temperatures, shock and vibration, temperature cycling, and IR reflow simulation. The MD-010 family is capable of meeting the following qualification tests:

### Environmental Compliance

Parameter	Conditions
Mechanical shock	MIL-STD-202, Method 213 condition B
Mechanical vibration	MIL-STD-202, Method 204 condition A
Resistance to solvents	MIL-STD-202, Method 215

## Handling Precautions

Although ESD protection circuitry has been designed into the MD-010 proper precautions should be taken when handling and mounting. VI employs a human body model (HBM) and a charged-device model (CDM) for ESD susceptibility testing and design protection evaluation.

### ESD Ratings

Model	Minimum	Conditions
Human body model	1500 V	MIL-STD-883C, Method 3015
Charged device model	1000 V	JEDEC, JESD22-C101

## Package Outline

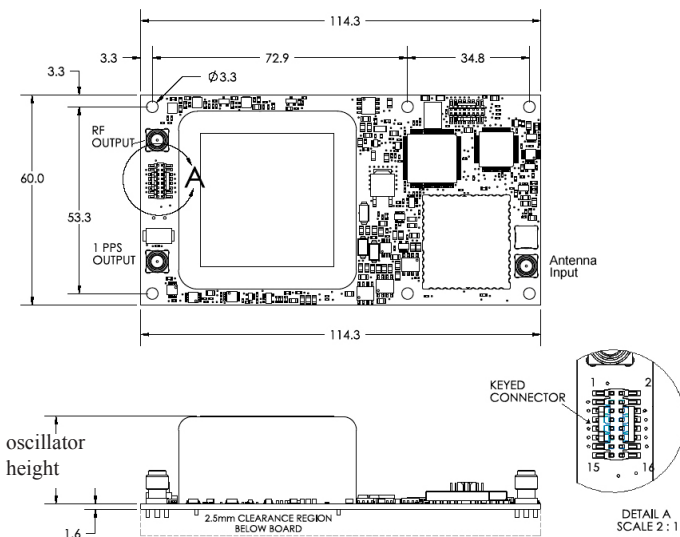

**Notes:**

- RF and 1pps input and output connectors are MCX type (SMA, SMB, MMCX connectors require additional part numbers).
- Keyed connector is Samtec FTSH-108-01LDVK type.
- Dimensions: mm
- Module height in part number is the sum of oscillator height, board, and clearance

### 16 Pin I/O Connections

Number	Name	Description
1	PPS In	External 1 PPS Input
2	PPS Out	1 PPS Output
3	Ground	Ground
4	Ground	Ground
5	Rx	Serial Communications Receive
6	Tx	Serial Communications Transmit
7	Vcc	Power Supply
8	RF Out	RF HCMOS Output
9	Locked	Logic-high = Output locked to PPS
10	Module OK	Logic low = Failure with module operation
11	ManHold	Manual Holdover Input
12	Reset	Hardware reset
13	Ground	Ground
14	Ground	Ground
15	Vcc	Power Supply
16	Vcc	Power Supply

## Accessories

Vectron Partnumber	Description
MD-010-EK	MD-010X-XXX-XXXX Module with Evaluation Kit

## Ordering Information Instructions

The MD-010 series of disciplined oscillators has multiple options with embedded OCXOs, Double OCXOs, EMXOs and TCXOs. Options are created to optimize customer hold over requirements while meeting pricing needs. Customization to unique customer requirements is available and is common for this level of integration. Common customizations include alternate output frequencies, temperature ranges, differing values and methods of hold over specification, and holdover optimization in the frequency domain. . Not all combinations of codes are available. The table below lists existing combinations available as of the date of publication of this data sheet. Please contact the factory for additional options.

## Ordering Information

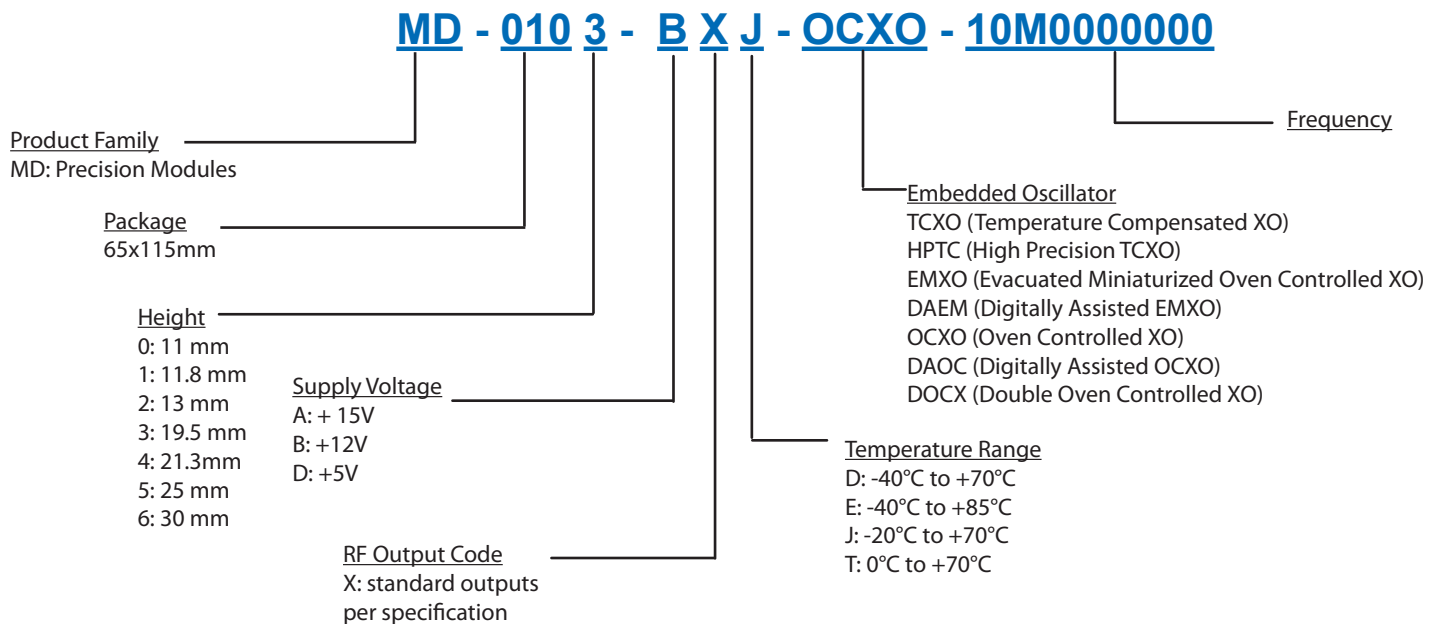

Available Models (standard models highlighted)

MD-0100-DXD-TCXO-10M0000000	MD-0102-DXD-HPTC-10M0000000	MD-0101-DXD-EMXO-10M0000000
MD-0100-DXE-TCXO-10M0000000	MD-0102-DXE-HPTC-10M0000000	MD-0101-DXE-EMXO-10M0000000
MD-0100-DXJ-TCXO-10M0000000	MD-0102-DXJ-HPTC-10M0000000	MD-0101-DXJ-EMXO-10M0000000
MD-0100-DXT-TCXO-10M0000000	MD-0102-DXT-HPTC-10M0000000	MD-0101-DXT-EMXO-10M0000000
MD-0101-DXD-DAEM-10M0000000	MD-0103-DXD-OCXO-10M0000000	MD-0103-DXD-DAOC-10M0000000
MD-0101-DXE-DAEM-10M0000000	MD-0103-DXE-OCXO-10M0000000	MD-0103-DXE-DAOC-10M0000000
MD-0101-DXJ-DAEM-10M0000000	MD-0103-DXJ-OCXO-10M0000000	MD-0103-BXJ-DAOC-10M0000000
MD-0101-DXT-DAEM-10M0000000	MD-0103-DXT-OCXO-10M0000000	MD-0103-BXT-DAOC-10M0000000
MD-0103-BXJ-OCXO-10M0000000	MD-0103-BXT-OCXO-10M0000000	MD-0104-BXJ-DOCX-10M0000000
	MD-0104-BXT-DOCX-10M0000000	

## Notes

- 1) Holdover and aging performance is after 7 days of power-on time.
- 2) Temperature stabilities apply to -20 to +70 °C modules. For other temperatures the temperature stability will vary, however the hold over values over defined temperature ranges remain constant.
- 3) 24 hour average when locked to external 1PPS
- 4) The status locked indicator is intended to indicate when the module is fully locked to external 1 pps.
- 5) The Hardware OK indicator is intended to indicate when the module is operating properly without any failures including hardware, software or parameter out of range, see protocol.
- 6) Open collector input bit.
- 7) If the minimum supply current is not exceeded, the Antenna Open Flag will be set. Over current will be set if maximum is exceeded. Circuit has overcurrent protection.
- 8) The Rx pin is the serial interface input and the Tx pin is the serial interface output. The serial interface shall operate at 9600 baud with eight (8) data bits, one (1) stop bit and no parity.
- 9) This holdover performance also applies to the temperature deviation over the entire operating range of -20 to +70°C.

## Application Notes

- 1) Holdover Contributions and Calculations - please contact for a copy
- 2) Vectron Discipline and Hold Over Process and Algorithms - please contact us for a copy
- 3) Utilizing Disciplined Oscillators as Frequency References - please contact factory

## For Additional Information, Please Contact

### USA:

Vectron International  
267 Lowell Road  
Hudson, NH 03051  
Tel: 1.888.328.7661  
Fax: 1.888.329.8328

### Europe:

Vectron International  
Landstrasse, D-74924  
Neckarbischofsheim, Germany  
Tel: +49 (0) 7268.801.100  
Fax: +49 (0) 7268.801.282

### Asia:

Vectron International  
1F-2F, No 8 Workshop, No 308 Fenju Road  
WaiGaoQiao Free Trade Zone  
Pudong, Shanghai, China 200131  
Tel: 86.21.5048.0777  
Fax: 86.21.5048.1881

### Disclaimer

Vectron International reserves the right to make changes to the product(s) and or information contained herein without notice. No liability is assumed as a result of their use or application. No rights under any patent accompany the sale of any such product(s) or information.

Rev: 4062010 dmc