

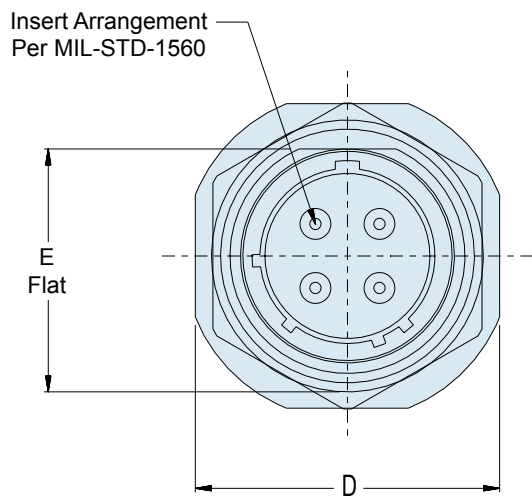

257-333
Hermetic Jam Nut Receptacle
with Crimp Removable Socket Contacts
MIL-DTL-38999 Series III Type

B

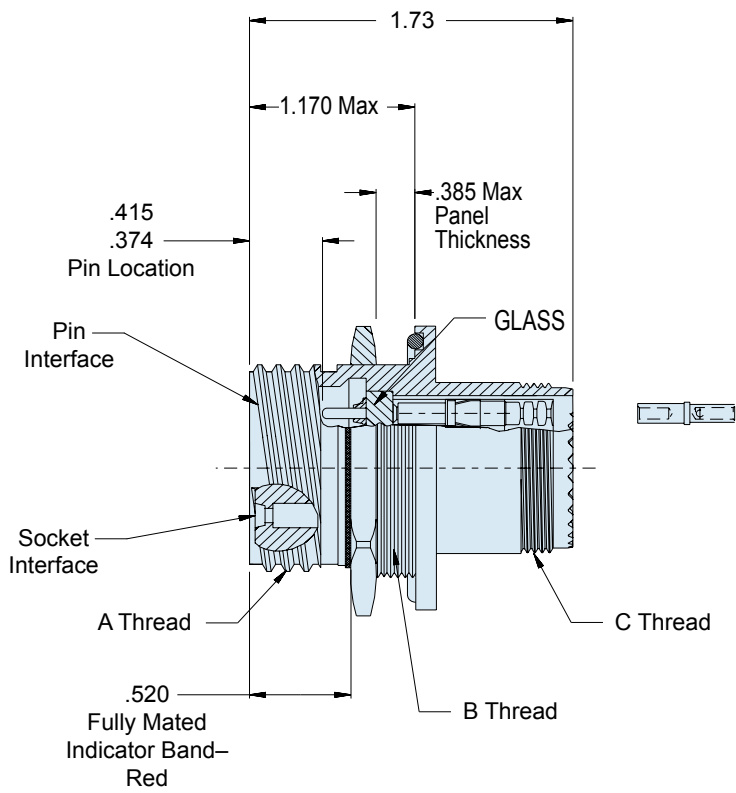
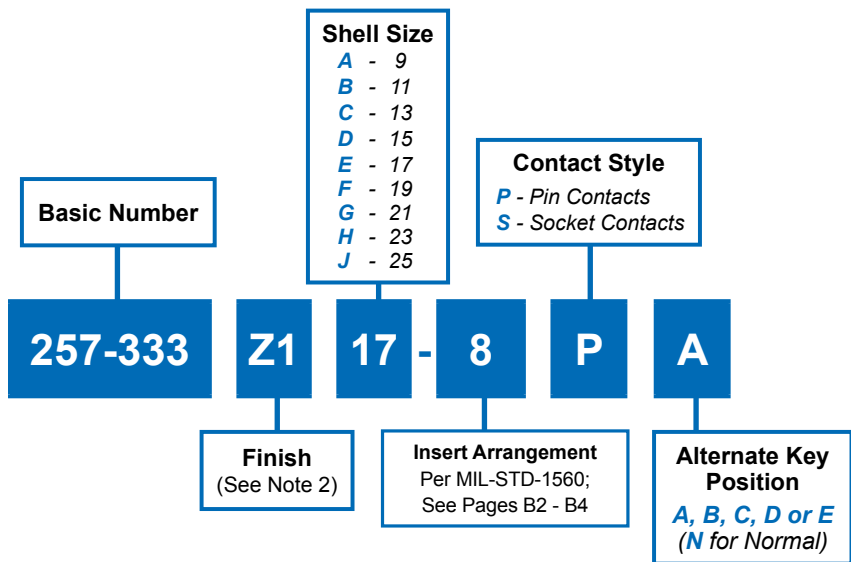

257-333
Hermetic Jam Nut Receptacle
with Crimp Removable Socket Contacts
MIL-DTL-38999 Series III Type



MIL-DTL
38999 Type

B

**TABLE I (CONTINUED):
CONNECTOR
DIMENSIONS**

SHELL SIZE CODE	K DIA ±.005(0.1)	N ±.005(0.1)
B	.827(21.0)	.764(19.4)
C	1.012(25.7)	.950(24.1)
D	1.139(28.9)	1.079(27.4)
E	1.266(32.2)	1.203(30.6)
F	1.389(35.3)	1.328(33.7)
G	1.512(38.4)	1.454(36.9)
H	1.639(41.6)	1.575(40.0)
J	1.764(44.8)	1.704(43.3)

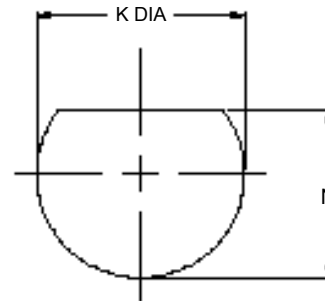

Recommended Panel
Cut-Out

HERMETIC LEAK RATE MOD CODES

Designator	Required Leak Rate
-585A	1 x 10 ⁻¹⁰ cc's Helium per second
-585B	1 x 10 ⁻⁹ cc's Helium per second
-585C	1 x 10 ⁻⁸ cc's Helium per second

TABLE I: CONNECTOR DIMENSIONS

SHELL SIZE	SHELL SIZE CODE	A THREAD	B THREAD	C THREAD	D +/- .016 (MM)	E +/- .004-.006 (MM)
9	A	.6250-.1P.3L-TS-2A	M17x1-6g 0.100R	M12x1-6g 0.100R	1.062 (2.70)	0.651 (1.65)
11	B	.7500-.1P.3L-TS-2A	M20x1-6g 0.100R	M15x1-6g 0.100R	1.252 (3.18)	0.751 (1.91)
13	C	.8750-.1P.3L-TS-2A	M25x1-6g 0.100R	M18x1-6g 0.100R	1.374 (3.49)	0.938 (2.38)
15	D	1.000-.1P.3L-TS-2A	M28x1-6g 0.100R	M22x1-6g 0.100R	1.500 (3.81)	1.062 (2.70)
17	E	1.1875-.1P.3L-TS-2A	M32x1-6g 0.100R	M25x1-6g 0.100R	1.626 (4.13)	1.187 (3.01)
19	F	1.250-.1P.3L-TS-2A	M35x1-6g 0.100R	M28x1-6g 0.100R	1.811 (4.60)	1.312 (3.33)
21	G	1.375-.1P.3L-TS-2A	M38x1-6g 0.100R	M31x1-6g 0.100R	1.937 (4.92)	1.437 (3.65)
23	H	1.500-.1P.3L-TS-2A	M41x1-6g 0.100R	M34x1-6g 0.100R	2.063 (5.24)	1.562 (3.97)
25	J	1.625-.1P.3L-TS-2A	M44x1-6g 0.100R	M37x1-6g 0.100R	2.189 (5.56)	1.687 (4.28)

APPLICATION NOTES

- Assembly to be identified with Glenair's name and part number and date code, space permitting.
- Material/finishes:
 Shell Receptacle, Jam Nut – CRES Passivated (Z1), CRES/NI (Z1)
 Pin Contact – alloy 52 / gold plated
 Socket Contact – copper alloy / gold plated
 Insulator – fused vitreous glass / N.A.
 Insulators – high grade rigid dielectric
 Seals—fluorosilicone / N.A.
 Hermeticity— 1x10⁻⁷ cc/second
- Crimp removable socket contacts to conform to:
 MIL-C-39029/57-358 – size 16;
 MIL-C-39029/57-357 – size 20;
 and MIL-C-39029/57-354 – size 22D (supplied loose)
 Supply 1 extra contact for each size used.