



aSC7511

LOW-VOLTAGE 2-WIRE DIGITAL TEMPERATURE SENSOR WITH THERMAL ALARM

PRODUCT SPECIFICATION

Fully Released Specification

Product Description

The aSC7511 is a high-precision CMOS temperature sensor with SMBus compatible serial digital interface, intended for use in PC thermal management applications. The aSC7511 can measure temperature of a remote thermal diode to an accuracy of $\pm 1^{\circ}\text{C}$. Internal temperature can be measured to $\pm 3^{\circ}\text{C}$.

Communication of configuration, temperature and alarm status takes place over the PC standard System Management Bus (SMBus).

The aSC7511 features thermal alarm functions with a user-programmable trip and turn-off temperatures. The THERM output comparator can be set to control a fan while ALERT signals that the remote or local temperature is outside of a range of temperatures. ALERT pin may be optionally configured as a second THERM output, THERM2, controlling a second fan.

The aSC7511 is available in SOP-8 and MSOP-8 surface mount packages.

Features

- Local and remote temperature sensors
- 0.25°C resolution, $\pm 1^{\circ}\text{C}$ accuracy on remote diode
- 1°C resolution, $\pm 3^{\circ}\text{C}$ accuracy on local sensor
- Extended temperature measurement range 0°C to $+127^{\circ}\text{C}$ (default) or -55°C to $+150^{\circ}\text{C}$
- 2-wire SMBus serial interface with SMBus alert
- Programmable over / under temperature limits
- Offset registers for system calibration
- One or two over-temperature fail-safe THERM outputs
- 8-lead, Pb-free, SOIC (SOP) or MSOP package

Applications

Desktop Computers – Motherboards and Graphics Cards
Laptop Computers

Ordering Information

Part Number	Package	Temperature Range and Operating Voltage	Marking	How Supplied
aSC7511D8	8-Lead SOP	-40°C to $+125^{\circ}\text{C}$, 3.3V	aSC7511 Ayww	2500 units Tape & Reel
aSC7511M8	8-Lead MSOP	-40°C to $+125^{\circ}\text{C}$, 3.3V	7511 Ayww	2500 units Tape & Reel

Ayww – Assembly site, year, workweek

Pin Configuration

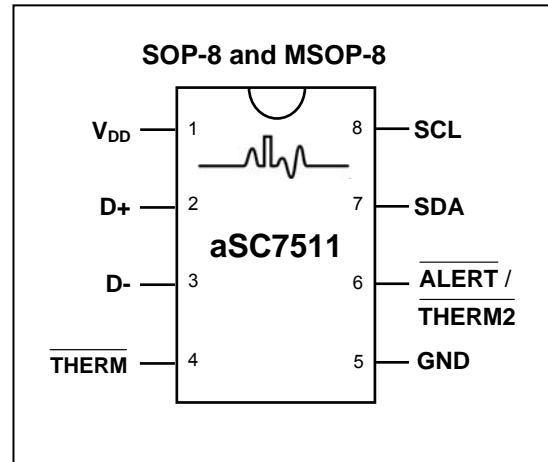

Application Diagram

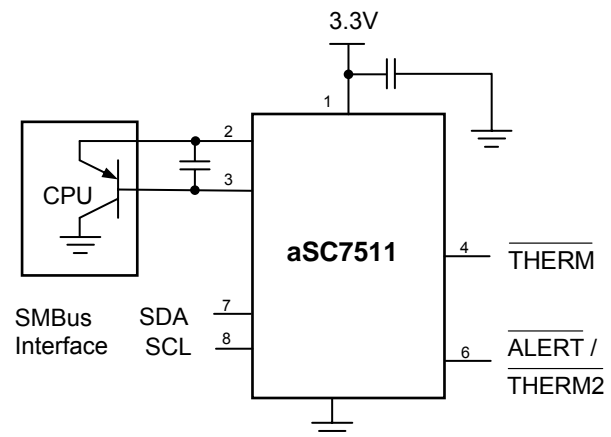

Absolute Maximum Ratings¹

Parameter	Rating	
Supply Voltage, V_{DD} , 3.3V nom.	-0.3, +3.6V	
Output Voltage	$V_{DD} + 0.5V$	
D+	-0.3V to $V_{DD} + 0.5V$	
D- to GND	-0.3V to 0.6V	
SDA, SCL, $\overline{\text{ALERT}}$, $\overline{\text{THERM}}$	-0.3V to 5.5V	
I/O Current, SCL, SDA, $\overline{\text{ALERT}}$, $\overline{\text{THERM}}$	-1mA	
Input Current, D-	$\pm 1\text{mA}$	
Continuous Current, any other terminal	10mA	
Storage Temperature Range	-60°C to +150°C	
IR Reflow Peak Temperature	260°C	
Lead Soldering Temperature (10 sec.)	300°C	
ESD ²	Human Body Model	> 2000 V
	Machine Model	> 250 V
	Charged Device Model	> 2000 V

Notes:

1. Absolute maximum ratings are limits beyond which operation may cause permanent damage to the device. These are stress ratings only; functional operation at or above these limits is not implied.
2. Human Body Model: 100pF capacitor discharged through a 1.5k Ω resistor into each pin. Machine Model: 200pF capacitor discharged directly into each pin. Charged Device Model is per JESD22-C101C.
3. These specifications are guaranteed only for the test conditions listed.
4. Accuracy (expressed in °C) = Difference between the aSC7511 reported output temperature and the temperature being measured.
5. Guaranteed by characterization but not production tested.
6. The accuracy of the aSC7511 is guaranteed when using the thermal diode of a processor or any thermal diode with a non-ideality of 1.008 and internal series resistance of 3.52 Ω . When using a 2N3904 type transistor as a thermal diode the error band will be typically shifted depending on transistor characteristics.
7. The aSC7511 can be read at any time without interrupting the temperature conversion process.

Electrical Characteristics³

(-40°C $\leq T_A \leq$ +125°C, $V_{DD} = 3.3V$ unless otherwise noted. Specifications subject to change without notice)

Parameter		Conditions	Min	Typ	Max	Units
Supply Voltage	V_{DD}		3.0	3.3	3.6	V
Operating Supply Current	I_{DD}	0.0625 Conversions-per-second rate		170	215	μA
		Standby Mode, -40°C $\leq T_A <$ +85°C		6	10	μA
		Standby Mode, +85°C $\leq T_A \leq$ +120°C		6	20	μA
Local Sensor Accuracy ⁴		-40°C $\leq T_A \leq$ +100°C, 3V $\leq V_{DD} \leq$ 3.6V		± 1	± 3	°C
Local Sensor Resolution				1		°C
Remote Sensor Accuracy ^{4,5,6}		+60°C $\leq T_A \leq$ +100°C, -55°C $\leq T_D \leq$ +150°C, 3V $\leq V_{DD} \leq$ 3.6V		± 1	± 2	°C
		-40°C $\leq T_A \leq$ +120°C, -55°C $\leq T_D \leq$ +150°C, 3V $\leq V_{DD} \leq$ 3.6V			± 3	°C
Remote Sensor Resolution				0.25		°C
Temperature Conversion Time ⁷		From Stop Bit to Conversion Complete, One-Shot Mode, 2 Sensors, Averaging On			115	ms
Temperature Conversion Time ⁷		One-Shot Mode, Averaging Off			30	ms

Logic Electrical Characteristics

($T_A = 25\text{ }^\circ\text{C}$, $V_{DD} = 3.3\text{V}$ unless otherwise noted)

Parameter	Symbol	Conditions	Min	Typ	Max	Units
Input Voltage Logic High	V_{IH}	$3\text{V} \leq V_{DD} \leq 3.6\text{V}$	2.1			V
Input Voltage Logic Low	V_{IL}	$3\text{V} \leq V_{DD} \leq 3.6\text{V}$			0.8	V
Output Voltage Logic Low ($\overline{\text{ALERT}}$ and $\overline{\text{THERM}}$)	V_{OL}	$V_{DD} = 3.6\text{V}$, $I_{OL} = -6\text{mA}$			0.4	V
Output Low Sink Current ($\overline{\text{ALERT}}$ and $\overline{\text{THERM}}$)	I_{OL}	$\overline{\text{ALERT}}$ or $\overline{\text{THERM}}$ forced to 0.4V	1			mA
Input Leakage Current	I_{IN}	$V_{IN} = 0\text{V}$ or 5.5V , $-40\text{ }^\circ\text{C} \leq T_A \leq +125\text{ }^\circ\text{C}$			± 1.0	μA
SMBus Output Sink Current	I_{OL}	$T_A = 25\text{ }^\circ\text{C}$, $V_{OL} = 0.6\text{V}$	6			mA
SMBus Logic Input Current	I_{IH}, I_{IL}		-1		+1	μA
Output Leakage Current	I_{OH}	$V_{OH} = V_{DD} = 3.6\text{V}$		0.1	1	μA
Output Transition Time	t_F	$C_L = 400\text{pF}$, $I_{OL} = -3\text{mA}$			250	ns
Input Capacitance	C_{IN}	All Digital Inputs			5	pF

Serial Port Timing

($T_A = 25\text{ }^\circ\text{C}$, $V_{DD} = 3.3\text{V}$ unless otherwise noted, Guaranteed by design, not production tested)

Parameter	Symbol	Min	Typ	Max	Units
SCL Operating Frequency	f_{SCL}			400	kHz
SCL Clock Transition Time	$t_{T:LH}$, $t_{T:HL}$			300	ns
SCL Clock Low Period	t_{LOW}	1.3			μs
SCL Clock High Period	t_{HIGH}	0.6		50	μs
Bus free time between a Stop and a new Start Condition	t_{BUF}	1.3			μs
Data in Set-Up to SCL High	$t_{SU:DAT}$	100			ns
Data Out Stable after SCL Low	$t_{HD:DAT}$	300			ns
SCL Low Set-up to SDA Low (Repeated Start Condition)	$t_{SU:STA}$	600			ns
SCL High Hold after SDA Low (Start Condition)	$t_{HD:STA}$	600			ns
SDA High after SCL High (Stop Condition)	$t_{SU:STO}$	600			ns
Time in which aSC7511 must be operational after a power-on reset	t_{POR}			500	ms

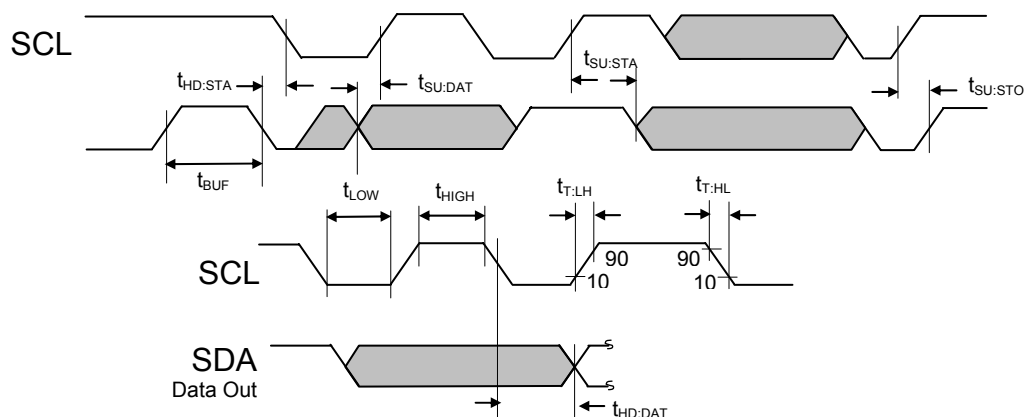

Pin Descriptions

Pin #	Name	Direction	Description
1	V _{DD}	Supply	Supply Voltage
2	D+	Current Source	Remote Diode Anode or Positive Lead
3	D-	Current Sink	Remote Diode Cathode or Negative Lead
4	THERM	Output	Open-drain logic output that may be used to control a fan or throttle CPU when programmed temperature limit is exceeded.
5	GND	Supply	Ground
6	ALERT / THERM2	Output	Open-drain logic output used as a mask-able interrupt or SMBus alert. Configurable as second THERM output.
7	SDA	Input/Output	Serial Data—Open drain I/O-data pin for two-wire serial interface.
8	SCL	Input	Serial Clock—Clock for two-wire serial interface.

Note: Open-drain pins require a pull-up resistor.

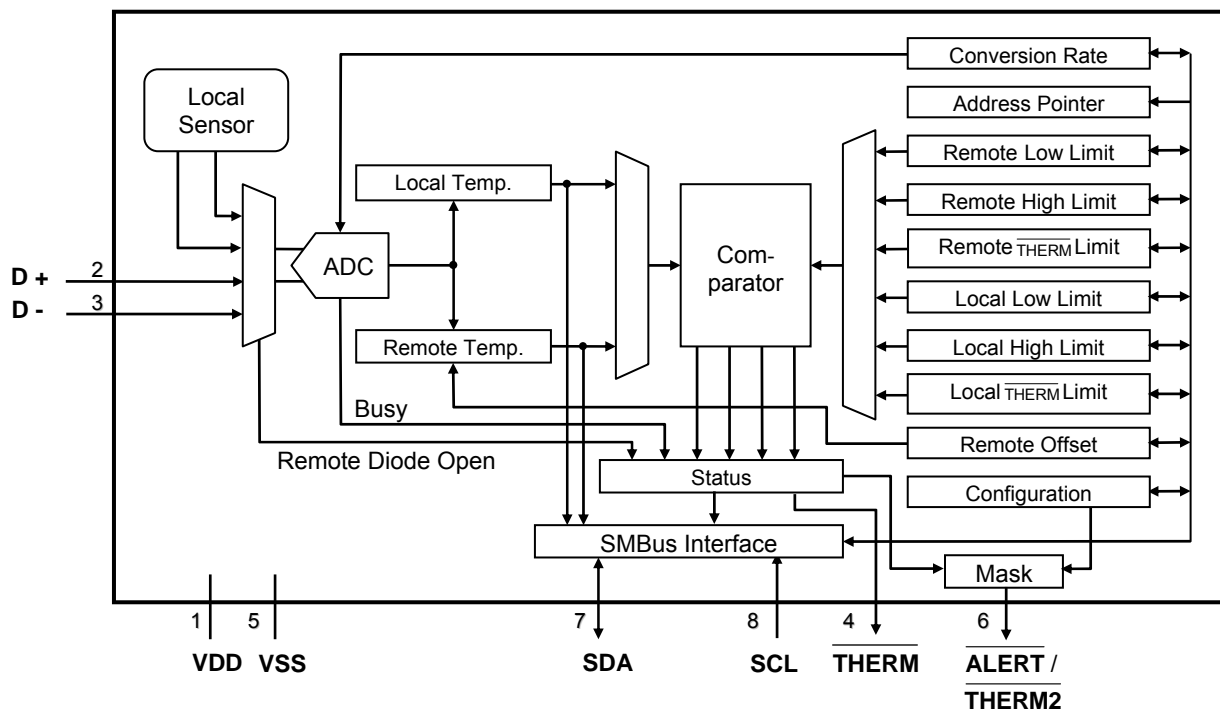

Figure 1. Block Diagram

Basic Operation Overview

The aSC7511 temperature sensing circuitry continuously monitors two thermal diode base-emitter voltages, one on-chip, called "local" and one remotely located, connected to the D+ and D- pins. At regular intervals the aSC7511 converts both analog voltages to digital values, which are placed into the temperature registers.

The aSC7511 has an SMBus-compatible serial interface that allows the user to access the data in the temperature registers at any time. In addition, the serial interface gives the user easy access to all other aSC7511 registers to customize operation of the device.

The aSC7511 temperature-to-digital converter has two temperature formats, 0°C to +127°C binary and extended-range, -55°C to +150°C, offset-binary. The local sensor resolution is 8-bits, with an LSB of 1°C. The remote or remote diode sensor resolution is 10-bits with an LSB of 0.25°C. The temperature range of the local and remote sensors are controlled by bit 2 of the configuration register, default value is 0, 0°C to 127°C.

Table 1 gives examples of the relationship between the output digital data and the measured temperature for the default range. Table 2 gives examples for the extended range. All output values are offset by +64°C when in this mode.

The aSC7511 has a Shutdown Mode that reduces the operating current to < 20µA. This mode is controlled by RUN / STOP, bit 6 in the configuration register. Comparisons to limits and diode open test are suspended until the next measurement has taken place.

Temperature	Digital Output (Binary)				
	High Byte		Low Byte		
	Always Zero				
Local Sensor	8-Bit Resolution		00	00	0000
Remote Sensor	10-Bit Resolution		00 0000		
>127°C	0111	1111	00	00	0000
+127°C	0111	1111	00	00	0000
+125°C	0111	1101	00	00	0000
+100°C	0110	0100	00	00	0000
+50°C	0011	0010	00	00	0000
+25°C	0001	1001	00	00	0000
+10°C	0000	1010	00	00	0000
+1.75°C	0000	0001	11	00	0000
+0.25°C	0000	0000	01	00	0000
0°C	0000	0000	00	00	0000
< 0°C	0000	0000	00	00	0000

Table 1. Relationship Between Temperature and Digital Output, Default Range, 0°C to +127°C

Temperature	Digital Output (Offset Binary)				
	High Byte		Low Byte		
	Always Zero				
Local Sensor	8-Bit Resolution		00	00	0000
Remote Sensor	10-Bit Resolution		00 0000		
+150°C	1101	0110	00	00	0000
+127°C	1011	1111	00	00	0000
+125°C	1011	1101	00	00	0000
+100°C	1010	0100	00	00	0000
+50°C	0111	0010	00	00	0000
+25°C	0101	1001	00	00	0000
+10°C	0100	1010	00	00	0000
+1.75°C	0100	0001	11	00	0000
+0.25°C	0100	0000	01	00	0000
0°C	0100	0000	00	00	0000
-55°C	0000	1001	00	00	0000

Table 2. Relationship Between Temperature and Digital Output, Extended Range, -55°C to +150°C

Power-Up Default Conditions

The aSC7511 always powers-up in the following default state:

- Configuration Register: 00h (i.e., $\overline{\text{ALERT}}$ enabled, Run Mode, $\overline{\text{ALERT}}$ pin selected, normal range)
- Conversion Rate: 16 per second, 08h
- All Temperature and Offset Registers: 00h
- Consecutive $\overline{\text{ALERT}}$: 1 fault (i.e., 01h in the register)
- Local and Remote Low Limit: 0°C
- Local and Remote $\overline{\text{THERM}}$ Limit: 85°C
- $\overline{\text{THERM}}$ Hysteresis: 10°C
- Register Address Pointer: Undefined, must be set by first write sequence.
- Normal / Extended Range: Normal

After power-up, these conditions can be reprogrammed via the serial interface. Refer to the Serial Data Bus Operation section to for aSC7511 programming instructions.

Temperature Measurement

The aSC7511 measures temperature by calculating the change in sensing a diode-connected transistor's base-emitter voltage (ΔV_{BE}) when two different currents are applied sequentially. This difference has a linear positive slope with temperature, unlike the non-linear VBE under a constant current.

The ΔV_{BE} is amplified and scaled depending on the type of transistor being measured. The typical case for the remote measurement is to connect to the substrate thermal diode of a CPU or ASIC. This will provide the die temperature of that device to a high level of accuracy for the purpose of controlling system cooling or reporting routine or over-temperature conditions.

For each measurement cycle, an internal 2:1 multiplexer alternates between the local and remote sensor diodes and provides the input to a filter and amplifier. An analog-to-digital converter takes this signal, converts it to a digital value and stores the alternating values in the appropriate temperature register of the aSC7511. These stored values are continuously compared to several user-selected limit values for sending alarm conditions or turning on an external fan driver.

Conversions for both sensors will proceed automatically at the default rate of 16 conversions per second until a different rate is selected or one-shot or stand-by mode are selected. The conversion rate is user-selected by writing to the conversion rate register. Table 3 provides a list of conversion rates ranging from 0.0625 to 64 conversions per second. Sensor power consumption is directly proportional to the conversion rate and should be taken into account in power-limited applications as well as the impact that power dissipation has in self-heating of the local sensor. More details are provided in the Operation section.

Thermal Alarm and Alert Functions

The aSC7511 thermal alarm function, \overline{THERM} , provides user programmable thermostat capability and allows the aSC7511 to function as a standalone thermostat without constant attention over the serial interface. This signal is an open drain output. When either the remote or local temperature reading exceeds the selected limits it goes low and will remain low until the measured temperature falls below the alarm limit by the amount set into the \overline{THERM} hysteresis register (default value is 10°C).

The aSC7511 thermal alert function, \overline{ALERT} , provides another open-drain pin that is driven low when either the internal or remote temperature is greater than the high limit or less than or equal to the low limit selected by the user. In addition, an SMBus Alert is generated, requiring the bus master to inquire on the SMBus which client has interrupted in order to re-set the alert. The \overline{ALERT} pin may be masked by the user with bit 7 of the configuration register.

Note that limit comparisons are triggered only by a measurement action, not by a change in limits. An actual alarm condition may exist but will not be reported until a measurement takes place. This should be taken into account when using slow conversion rates.

The \overline{ALERT} pin may also be configured as a second \overline{THERM} pin, $\overline{THERM2}$. This will behave in the same way as the \overline{THERM} pin, but will be controlled by the high limit used for the \overline{ALERT} pin, although it will not need to be reset by the master and does not use the hysteresis value. A more detailed discussion and examples is provided in the Operation section.

Fault Tolerance

The number of out of limit readings required before the \overline{ALERT} is asserted may be set by writing to the Consecutive \overline{ALERT} register. The default value is 1 and the user may select requiring 2, 3, or 4 consecutive out of limit readings before \overline{ALERT} is asserted.

Registers

The aSC7511 contains 22 8-bit registers. All of these registers may be accessed by the user via the digital serial interface at any time. A detailed description of these registers and their functions is provided in the following paragraphs. Reading and writing to registers is covered in the SMBus Operation section. Use of the register set to control and interrogate the aSC7511 is covered in the Operation section. A table of the registers is provided in Table 4.

Address Pointer Register

The Address Pointer Register is a write-only register that is automatically written by the first byte that follows the R/W bit of a write transaction. If R/W is low, it will then contain the address to which the following byte is written, when R/W bit is high it will be the read address. Details of the reading and writing sequence are covered in the Serial Interface Operation section.

Measured Temperature Value Registers

The aSC7511 has two sensors whose measured values are stored in registers. Remote temperature is two bytes, at register addresses 01h and 10h. Local temperature is at 00h. The power-on default values are zero and the aSC7511 will automatically begin filling these registers with values after the power on reset sequence is complete. These are read-only registers.

Configuration Register

The configuration register is a read-write register that stores the controls for masking the $\overline{\text{ALERT}}$ signal, RUN / STOP control, extended temperature range select and the pin 6 function select for $\overline{\text{ALERT}}$ or $\overline{\text{THERM2}}$. It is located at address 03h for read and 09h for writing.

Power on default is for all bits reset: no $\overline{\text{ALERT}}$ mask, RUN, pin 6 is $\overline{\text{ALERT}}$ and normal range, 0°C to 127°C. Table 5 lists the bits of the configuration register.

The $\overline{\text{mask}}$ bit is only functional when pin 6 is configured as the $\overline{\text{ALERT}}$ pin. When selecting extended range, note that the values reported will be offset by 64°C and any limits will have to be adjusted accordingly to match this offset-binary coding. It is recommended that this configuration not be changed again, once selected, to avoid confusion.

Bit	Name	Function
0, 1	Reserved	
2	Range Select	0 = 0°C to +127°C 1 = -55°C to +150°C
3, 4	Reserved	
5	$\overline{\text{ALERT}} / \overline{\text{THERM2}}$	0 = pin 6 is $\overline{\text{ALERT}}$ 1 = pin 6 is $\overline{\text{THERM2}}$
6	RUN / STOP	0 = RUN 1 = STOP
7	MASK	0 = $\overline{\text{ALERT}}$ Enabled 1 = $\overline{\text{ALERT}}$ Masked

Table 5. Configuration Register Bit Assignments

Conversion Rate Register

The sensor conversion rate register sets the rate of conversions. Both local and remote sensors are measured during a measurement cycle.

Conversions per Second	Seconds per Conversion	Code
0.0625	16	00h
0.125	8	01h
0.25	4	02h
0.5	2	03h
1	1	04h
2	0.5	05h
4	0.25	06h
8	0.125	07h

16	0.0625	08h
32	0.03125	09h
64	0.015625	0Ah
Reserved	Reserved	0Bh to FFh

Table 6. Conversion Rate Register Bit Assignments

The conversion rate register may be written-to at address 04h. The value stored may be read back at any time from address 0Ah. The lower four bits define the rate from 0.0625 to 64 conversions per second. The default rate is 16 conversions per second designated by a code of 08h. The rates are described in Table 6.

A single measurement is controlled separately by the one-shot register, 0Fh, that is described below.

$\overline{\text{ALERT}}$ Limit Registers

There are four limit registers for the $\overline{\text{ALERT}}$ function using six register locations:

- $\overline{\text{ALERT}}$ Remote High Limit (high and low bytes)
- $\overline{\text{ALERT}}$ Remote Low Limit (high and low bytes)
- $\overline{\text{ALERT}}$ Local High Limit
- $\overline{\text{ALERT}}$ Local Low Limit

These registers may be written or read-back at any time at the addresses in shown in Table 2. Each limit has a default value at power-up of 85°C for the high limit and 0°C for the low limit. The $\overline{\text{ALERT}}$ high limits have a dual purpose in that they may be used to control the alternate function of pin 6, the $\overline{\text{ALERT}} / \overline{\text{THERM2}}$ output when that mode is selected.

Note that the values in the alarm registers must match the data format selected by bit 2, the normal / extended range selector in the configuration register. The user should choose either normal or extended range on power-up and not change this setting otherwise all limits will be invalid and have to be adjusted accordingly.

Operation of these registers in thermal management applications is described in the Operation Section.

One-Shot Register

While the aSC7511 is in standby mode with configuration register bit 6 high, a single measurement cycle may be initiated by a write to the one-shot register at address 0Fh. Any data written is ignored. After the conversion is completed a set of readings is written to the temperature registers, comparisons made and alerts generated. The aSC7511 will then return to standby mode, awaiting the

next one-shot reading or full activation. Standby mode is discussed further in the Operation section.

THERM Limit Registers

There are two limit registers for the THERM function:

- THERM Remote High Limit
- THERM Local High Limit

These registers may be written or read-back at any time at the addresses in shown in Table 2. Both limits has a default value at power-up of 85°C.

The THERM alarm will be set when this limit is exceeded and will reset when the temperature falls below that limit.

However, there is also a THERM hysteresis register that may be used to set the temperature difference below the THERM limit setting where the THERM alarm will be reset once it has been triggered. This value is defaulted to 10°C and may be set to any value after power-on. Operation of these registers in thermal management applications is described in the Applications Section.

Remote Sensor Offset Register

Offset errors may be encountered on the remote sensor readings caused by factors such as system clock noise induced into the sensor interconnect or by a difference between the measured temperature and the actual temperature of interest in the system. A correction offset value may be provided by the user to add or subtract from the measured value resulting in a corrected value being stored in the remote temperature registers. The limit values will then be compared to these corrected values.

The offset register coding is two's complement and it is allocated two bytes at addresses 11h and 12h. Table 7 describes some examples of values in the range from -128°C to +127.75°C that may be applied.

Offset Value	Offset Register High Byte (11h)	Offset Register Low Byte (11h)
+127.75°C	0111 1111	11 00 0000
+4°C	0000 0100	00 00 0000
+1°C	0000 0001	00 00 0000
+0.5°C	0000 0000	10 00 0000
0°C	0000 0000	00 00 0000
-0.5°C	1111 1111	10 00 0000
-1°C	1111 1111	00 00 0000
-4°C	1111 1100	00 00 0000
-128°C	1000 0000	00 00 0000

Table 7. Offset Register Sample Codes

Consecutive ALERT Register

This register will set the number of out of limit value readings it will require before ALERT is asserted. It is stored at register address 22h. The default value is for a single out of limit reading to assert ALERT. The register values for up to 4 out-of-limit readings are found in Table 8.

Number of Out-of-Limit Measurements Required	Register Value
1	yxxx 000x
2	yxxx 001x
3	yxxx 011x
4	yxxx 111x

x = Don't Care
y = SMBus Timeout Enable

Table 8. Consecutive Alert Register

This register is also used to control activation of the SMBus timeout feature. It is disabled by default and enabled by writing a 1 to the MSB, bit 7.

Manufacturer's Registers

Manufacturer's identification is stored in the register at address FEh and set to the value 61h. Register FFh contains the die revision code.

Serial Data Bus Operation

General Operation

Writing to and reading from the aSC7511 registers is accomplished via the SMBus-compatible two-wire serial interface. SMBus protocol requires that one device on the bus initiate and control all read and write operations. This device is called the "master" device. The master device also generates the SCL signal that is the clock signal for all other devices on the bus. All other devices on the bus are called "slave" devices. The aSC7511 is a slave device. Both the master and slave devices can send and receive data on the bus.

During SMBus operations, one data bit is transmitted per clock cycle. All SMBus operations follow a repeating nine clock-cycle pattern that consists of eight bits (one byte) of transmitted data followed by an acknowledge (ACK) or not acknowledge (NACK) from the receiving device. Note that there are no unused clock cycles during any operation—therefore there must be no breaks in the stream of data and ACKs / NACKs during data transfers.

For most operations, SMBus protocol requires the SDA line to remain stable (unmoving) whenever SCL is high — i.e.

any transitions on the SDA line can only occur when SCL is low. The exceptions to this rule are when the master device issues a start or stop condition. Note that the slave device cannot issue a start or stop condition.

The aSC7511 supports packet error checking (PEC) per the SMBus protocol. It will interpret the PEC byte when provided and respond with a PEC byte when expected by the master. The PEC byte is calculated using CRC-8 and conforms to the frame check sequence with the polynomial:

$$C(x) = x^8 + x^2 + x^1 + 1$$

Refer to SMBus specification 2.0 for more details.

SMBus Definitions

The following are definitions for some general SMBus terms:

Start Condition: This condition occurs when the SDA line transitions from high to low while SCL is high. The master device uses this condition to indicate that a data transfer is about to begin.

Stop Condition: This condition occurs when the SDA line transitions from low to high while SCL is high. The master device uses this condition to signal the end of a data transfer.

Acknowledge and Not Acknowledge: When data are transferred to the slave device it sends an "acknowledge" (ACK) after receiving each byte. The receiving device sends an ACK by pulling SDA low for one clock. Following the last byte, a master device sends a "not acknowledge" (NACK) followed by a stop condition. A NACK is indicated by forcing SDA high during the clock after the last byte.

Slave Address

Each slave device on the bus has a unique 7-bit SMBus slave address. The aSC7511's slave address is 4C hex.

Writing to and Reading from the aSC7511

All read and write operations must begin with a start condition generated by the master device. After the start condition, the master device must immediately send a slave address (7-bits) followed by a R/W bit. If the slave address matches the address of the aSC7511, it sends an ACK by pulling the SDA line low for one clock. Read or write operations may contain one- or two-bytes. See Figures 2 through 6 for timing diagrams for all aSC7511 operations.

Setting the Register Address Pointer

For all operations, the address pointer stored in the address pointer register must be pointing to the register address that is going to be written to or read from. This

register's content is automatically set to the value of the first byte following the R/W bit being set to 0.

After the aSC7511 sends an ACK in response to receiving the address and R/W bit, the master device must transmit an appropriate 8-bit address pointer value as explained in the Registers section of this data sheet. The aSC7511 will send an ACK after receiving the new pointer data.

The register address pointer set operation is illustrated in Figure 2. If the address pointer is not a valid address the aSC7511 will internally terminate the operation. Also recall that the address register retains the current address pointer value between operations. Therefore, once a register is being pointed to, subsequent read operations do not require another Address Pointer set cycle.

Writing to Registers

All writes must start with a pointer set as described previously, even if the pointer is already pointing to the desired register. The sequence is described in Figure 3.

Immediately following the pointer set, the master must begin transmitting the data to be written. After transmitting each byte of data, the master must release the SDA line for one clock to allow the aSC7511 to acknowledge receiving the byte. The write operation should be terminated by a stop condition from the master.

Reading from Registers

To read from a register other than the one currently being pointed to by the address pointer register, a pointer set sequence to the desired register must be done as described previously. Immediately following the pointer set, the master must perform a repeat start condition that indicates to the aSC7511 that a read is about to occur. It is important to note that if the repeat start condition does not occur, the aSC7511 will assume that a write is taking place, and the selected register will be overwritten by the upcoming data on the data bus. The read sequence is described in Figure 4. After the start condition, the master must again send the device address and read/write bit.

This time the R/W bit must be set to 1 to indicate a read. The rest of the read cycle is the same as described in the previous paragraph for reading from a preset pointer location.

If the pointer is already pointing to the desired register, the master can read from that register by setting the R/W bit (following the slave address) to a 1. After sending an ACK, the aSC7511 will begin transmitting data during the following clock cycle. After receiving the 8 data bits, the master device should respond with a NACK followed by a stop condition.

If the master is reset while the aSC7511 is in the process of being read, the master should perform an SMBus reset. This is done by holding the data or clock low for more than

35ms, allowing all SMBus devices to be reset. This follows the SMBus 2.0 specification of 25-35ms.

When the aSC7511 detects an SMBus reset, it will prepare to accept a new start sequence and resume communication from a known state

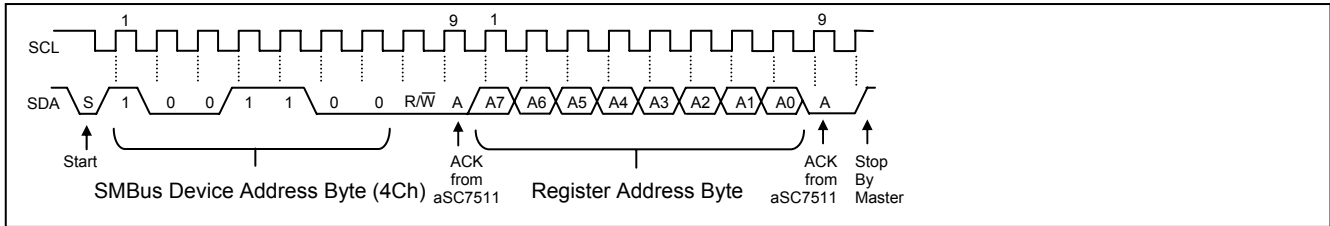

Figure 2. Register Address Pointer Set

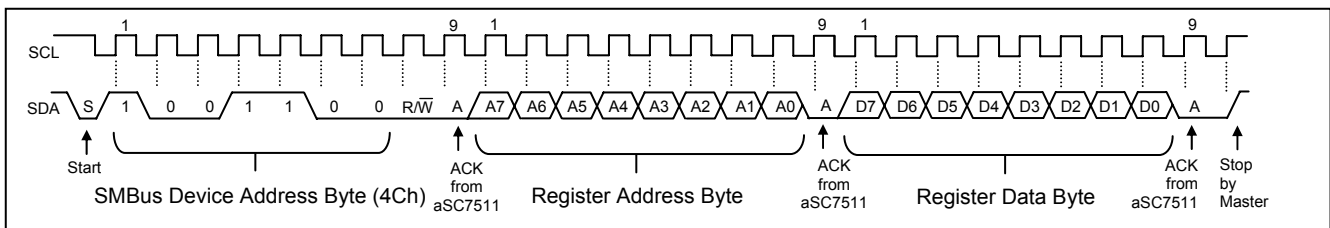

Figure 3. Register Write

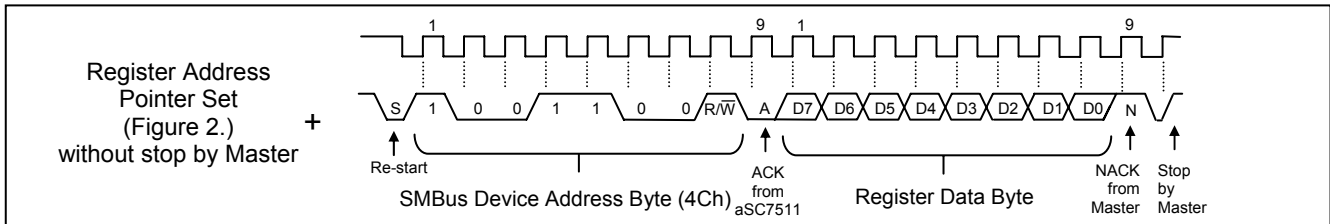

Figure 4. Register Read

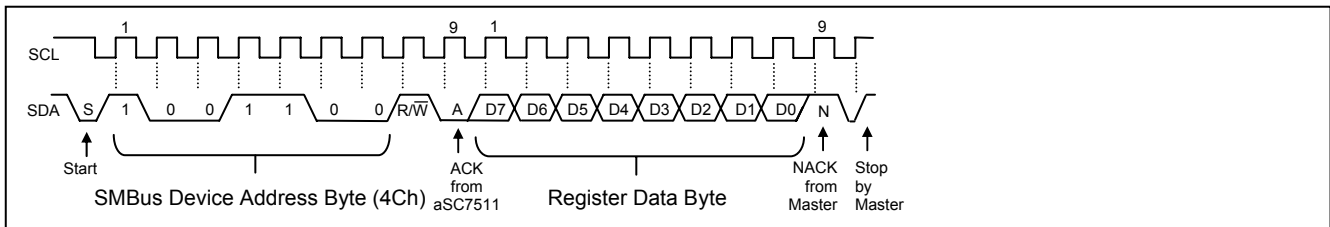

Figure 5. Register Read When Read Address Already Set

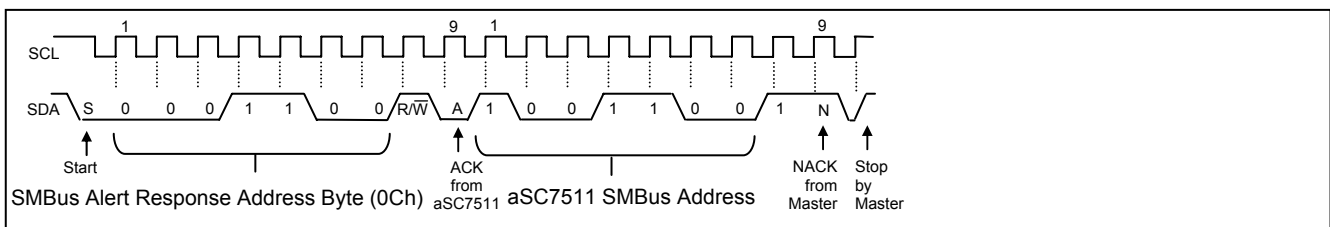

Figure 6. SMBus Alert Response

Operation

Alarm Outputs

The aSC7511 has two alarm functions, $\overline{\text{ALERT}}$ and $\overline{\text{THERM}}$. $\overline{\text{THERM}}$ has a high temperature limit and $\overline{\text{ALERT}}$ has both high and low limits and will also respond to a remote diode open circuit failure. These limits are settable separately for the local and remote sensors. Any alarm condition is reported individually in the status register and may be read at any time on the SMBus. Alarm conditions are logically combined and used to drive two open-drain outputs, the $\overline{\text{ALERT}}$ output, (pin 6) and $\overline{\text{THERM}}$ output, (pin 4).

Output pins may be used as an interrupt signal the CPU or to turn on remote drivers for fans or indicators. The $\overline{\text{ALERT}}$ pin will remain asserted until it has been reset by the host via the SMBus. The $\overline{\text{THERM}}$ pin will remain asserted until the temperature falls below the alarm level by the amount set into the $\overline{\text{THERM}}$ hysteresis register.

ALERT Limits

Figure 7 shows use of the $\overline{\text{ALERT}}$ high and low limits. The user sets up the alarm by writing the upper and lower limit temperatures into the limit registers over the SMBus. After each measurement, the comparator tests the readings against the programmed limits and if the measurement exceeds the high limit is or is equal to or less-than the low limit, it will assert the particular alarm bits in the status register and cause the $\overline{\text{ALERT}}$ pin to go low.

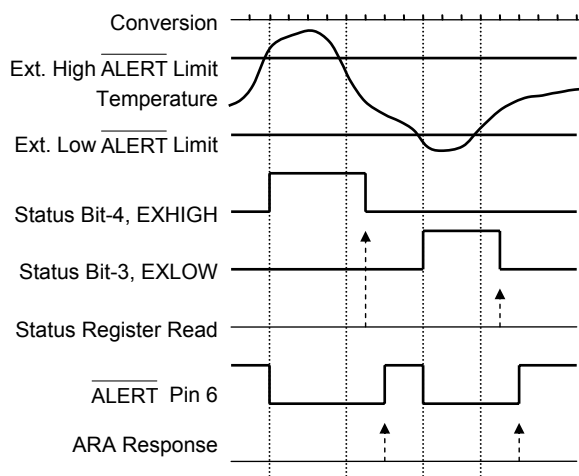

Figure 7. $\overline{\text{ALERT}}$ Limits and Responses

The status bits will remain high until the status register is read and then, if the condition is no longer present those

bits will be reset, otherwise they will remain high until the conditions are no longer met and the register is read again. The same sequence applies to the local readings and limits.

The $\overline{\text{ALERT}}$ pin will remain low until the status bits have been reset and an Alert Response has been issued by the master and responded by the aSC7511. This flow is described below.

The user may mask-out or disable the $\overline{\text{ALERT}}$ signal pin should it be necessary to prevent a processor interrupt. This is controlled by setting bit 7 of the configuration register.

SMBus Alert Output

The $\overline{\text{ALERT}}$ pin may be used to signal an SMBus Alert to the host processor. This is a special mode of the SMBus interface that requires the SMBus host to send an Alert Response Address (ARA) to all slaves sharing the $\overline{\text{ALERT}}$ pin in order to isolate clear and service the alerting device. This sequence is described below and in Figure 6.

The sequence of servicing this interrupt is as follows:

1. $\overline{\text{SMBALERT}}$ is asserted by the aSC7511 driving pin 6 low.
2. The SMBus master begins a read operation with a start followed by the ARA response address, 0001 100. This is an SMBus General Call Address to be used only for requesting an alert response. The
3. The device providing the $\overline{\text{SMBALERT}}$ signal responds to this by providing an ACK followed by its own bus address, an aSC7511 will provide, 100 1100, with the LSB of the data byte set to 1. A NACK response is expected from all devices not giving an $\overline{\text{SMBALERT}}$.
4. If more than one device responds, the device with the lowest device address will have priority and will be serviced first by the master.
5. When the aSC7511 has responded with its own address, it will de-assert the $\overline{\text{ALERT}}$ pin and the status register bit that caused it, if that condition and no other $\overline{\text{ALERT}}$ condition no longer exist.

THERM Limits

The $\overline{\text{THERM}}$ alarms operate differently from the alert alarms. $\overline{\text{THERM}}$ alarm status bits for remote and local

limits, $\overline{\text{RTHERM}}$ and $\overline{\text{LTHERM}}$, will change as soon as a reading is greater than the limit and will reset as soon as a reading goes below the limit minus the programmable hysteresis value.

This hysteresis value applies to both remote and local sensors. The scenario is described in Figure 8.

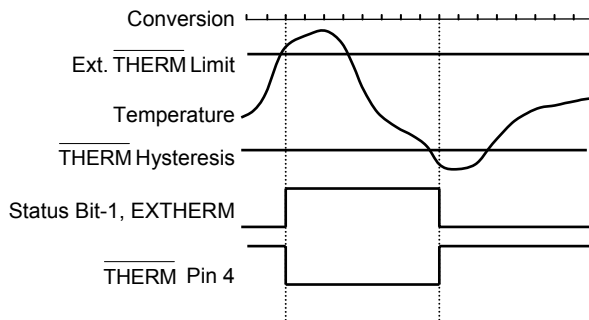

Figure 8. $\overline{\text{THERM}}$ Limits and Responses

The $\overline{\text{THERM}}$ limits default to 85°C with 10°C hysteresis. The hysteresis value may be set from 0°C to any positive value up to 127°C.

All limit values must take into account whether measurements are being made in normal or extended range. In extended range, there is a 64°C offset in reported values and limits must be adjusted accordingly.

$\overline{\text{THERM2}}$ Option

The $\overline{\text{ALERT}}$ pin and associated alarm bits may be re-assigned as a second $\overline{\text{THERM}}$ alarm. This alarm will work exactly like $\overline{\text{THERM}}$. The $\overline{\text{ALERT}}$ mask will have no effect and there is only a high limit. The $\overline{\text{THERM}}$ hysteresis value is applied to this alarm.

Sensor Open Detect

A protective circuit monitors the D+ pin for a voltage level that would indicate the path to the remote diode is open. If the voltage exceeds a typical value of $V_{\text{DD}}-1\text{V}$, bit 2 of the status register and the $\overline{\text{ALERT}}$ flag are set and the $\overline{\text{ALERT}}$ pin is driven low.

This will require the master to service the $\overline{\text{ALERT}}$ in order to reset the condition. If the remote diode is not being used, it is recommended that D+ and D- be shorted to prevent setting the open alarm.

In the event that a remote diode open-circuit has caused an $\overline{\text{ALERT}}$ condition to occur and that condition is restored to normal, when the host sends an Alert Response and reads the Status Register the alert pin may not clear. To ensure that the $\overline{\text{ALERT}}$ pin clears, perform a read to internal register 42h.

Standby Mode

The aSC7511 may be placed in a minimum-power standby mode by writing a 1 to bit 6 of the configuration register. No measurements are made but the SMBus interface will respond when addressed.

Any measurement in progress when standby is selected will be terminated and no new values will be written into the temperature registers.

While in this mode, a one-shot measurement of both channels may be commanded by the user by writing any data value to the one-shot register, 0Fh. All alarm comparisons will continue to be made and reported. The alarm values may be changed while in standby and current measured temperatures will be compared and alarms generated if an out-of-limit condition exists.

Operating current will be 10 μA or less when there is no activity on the SMBus and 100 μA or less when clock and data are active.

Applications Information

Remote Diodes

The aSC7511 is designed to work with a variety of remote sensors in the form of the substrate thermal diode of a CPU or graphics controller or a diode-connected transistor. Actual diodes are not suited for these measurements.

There is some variation in the performance of these diodes, described in terms of its departure from the ideal diode equation. This factor is called diode non-ideality, nf .

The equation relating diode temperature to a change in thermal diode voltage with two driving currents is:

$$\Delta V_{\text{BE}} = (nf) \frac{KT}{q} \ln(N)$$

where:

nf = diode non-ideality factor, (nominal 1.008).

K = Boltzman's constant, (1.38×10^{-23}).

T = diode junction temperature in Kelvins.

q = electron charge (1.6×10^{-19} Coulombs).

N = ratio of the two driving currents (16).

The aSC7511 is designed and trimmed for an expected nf value of 1.008, based on the typical value for the Intel Pentium™ III and AMD Athlon™. There is also a tolerance on the value provided. The values for other CPUs and the 2N3904 may have different nominal values and tolerances. Consult the CPU or GPU manufacturer's data sheet for the nf factor. Table 8 gives a representative sample of what one may expect in the

range of non-ideality. The trend with CPUs is for a lower value with a larger spread.

When thermal diode has a non-ideality factor other than 1.008 the difference in temperature reading at a particular temperature may be interpreted with the following equation:

$$T_{actual} = T_{reported} \left(\frac{1.008}{n_{actual}} \right)$$

where:

$T_{reported}$ = reported temperature in temperature register.

T_{actual} = actual remote diode temperature.

n_{actual} = selected diode's non-ideality factor, n_f .

Temperatures are in Kelvins or °C + 273.15.

The temperature error caused by non-ideality difference is directly proportional to the difference from 1.008, but a small difference in non-ideality results in a relatively large difference in temperature reading. For example, if there were a ±1% tolerance in the non-ideality of a diode it would result in a ±2.7 degree difference (at 0°C) in the result (0.01 x 273.15).

This difference varies with temperature such that a fixed offset value may only be used over a very narrow range. Typical correction method required when measuring a wide range of temperature values is to scale the temperature reading in the host firmware.

Part	n_f Min	n_f Nom	n_f Max
Pentium™ III (CPUID 68h)	1.0057	1.008	1.0125
Pentium 4, 130nM	1.001	1.002	1.003
Pentium 4, 90nM		1.011	
Intel Pentium M	1.0015	1.0022	1.0029
AMD Athlon™ Model 6	1.002	1.008	1.016
AMD Duron™ Models 7 and 8	1.002	1.008	1.016
AMD Athlon Models 8 and 10	1.0000	1.0037	1.0090
2N3904	1.003	1.0043	1.005

Table 8. Representative CPU Thermal Diode and Transistor Non-Ideality Factors

CPU or ASIC Substrate Remote Diodes

A substrate diode is a parasitic PNP transistor that has its collector tied to ground through the substrate and the base (D-) and emitter (D+) brought out to pins. Connection to these pins is shown in Figure 13. The non-ideality figures in Table 8 include the effects of any package resistance and represent the value seen from

the CPU socket. The temperature indicated will need to be compensated for the departure from a non-ideality of 1.008.

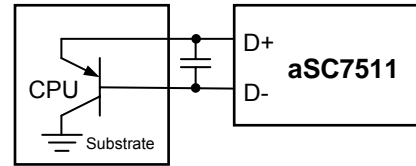

Figure 9. CPU Remote Diode Connection

Series Resistance

Any resistance in the connections from the aSC7511 to the CPU pins should be accounted for in interpreting the results of a measurement.

The impact of series resistance on the measured temperature is a result of measurement currents developing offset voltages that add to the diode voltage. This is relatively constant with temperature and may be corrected with a fixed value in the offset register. To determine the temperature impact of resistance is as follows:

$$\Delta T_R = R_S \times T_V \times \Delta I_D$$

or,

$$\Delta T_R = R_S \times \frac{90 \mu A}{230 \mu V / ^\circ C} = R_S \times 0.39 I^\circ C / \Omega$$

where:

ΔT_R = difference in the temperature reading from actual.

R_S = total series resistance of interconnect (both leads).

ΔI_D = difference in the two diode current levels (90µA).

T_V = scale of temperature vs. V_{BE} (230µV/°C).

For example, a total series resistance of 10Ω would give an offset of +3.9°C.

Discrete Remote Diodes

When sensing temperatures other than the CPU or GPU substrate, an NPN or PNP transistor may be used. Most commonly used are the 2N3904 and 2N3906. These have characteristics similar to the CPU substrate diode with non-ideality around 1.003. They are connected with base to collector shorted as shown in Figure 14.

While it is important to minimize the distance to the remote diode to reduce high-frequency noise pickup, they may be located many feet away with proper shielding. Shielded, twisted-pair cable is recommended, with the shield connected only at the aSC7511 end as close as possible to the ground pin of the device.

As with the CPU substrate diode, the temperature reported will be subject to the same errors due to non-

ideality variation and series resistance. However, the transistor's die temperature is usually not the temperature of interest and care must be taken to minimize the thermal resistance and physical distance between that temperature and the remote diode. The offset and response time will need to be characterized by the user.

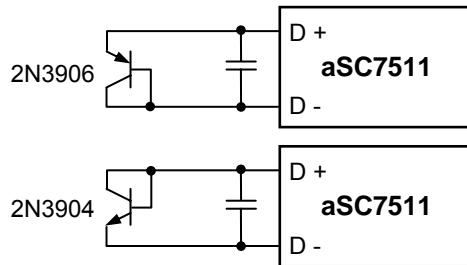

Figure 10. Discrete Remote Diode Connection

Board Layout Considerations

The distance between the remote sensor and the aSC7511 should be minimized. All wiring should be defended from high frequency noise sources and a balanced differential layout maintained on D+ and D-.

Any noise, both common-mode and differential, induced in the remote diode interconnect may result in an offset in the temperature reported. Circuit board layout should follow the recommendation of Figure 15. Basically, use 10-mil lines and spaces with grounds on each side of the differential pair. Choose the ground plane closest to the CPU when using the CPU's remote diode.



Figure 11. Recommended Remote Diode Circuit Board Interconnect

Noise filtering is accomplished by using a bypass capacitor placed as close as possible to the aSC7511 D+ and D- pins. A 2.2nF ceramic capacitor is recommended, but up to 3.3nF may be used. Additional filtering takes place within the aSC7511.

It is recommended that the following guidelines be used to minimize noise and achieve highest accuracy:

1. Place a 0.1μF bypass capacitor to digital ground as close as possible to the power pin of the aSC7511.
2. Match the trace routing of the D+ and D- leads and use a 2.2nF filter capacitor close to the aSC7511.

Use ground runs along side the pair to minimize differential coupling as in Figure 14.

3. Place the aSC7511 as close to the CPU or GPU remote diode leads as possible to minimize noise and series resistance.
4. Avoid running diode connections close to or in parallel with high-speed busses, staying at least 2cm away.
5. Avoid running diode connections close to on-board switching power supply inductors.
6. PC board leakage should be minimized by maintaining minimum trace spacing and covering traces over their full length with solder mask.

Thermal Considerations

The temperature of the aSC7511 will be close to that of the PC board on which it is mounted. Conduction through the leads is the primary path for heat flow. The reported local sensor is very close to the circuit board temperature and typically between the board and ambient.

In order to measure ambient air temperature, a remote diode-connected transistor should be used. A surface-mount SOT-23 or SOT-223 is recommended. The small size is advantageous in minimizing response time because of its low thermal mass, but at the same time it has low surface area and a high thermal resistance to ambient air. A compromise must be achieved between minimizing thermal mass and increasing the surface area to lower the junction-to-ambient thermal resistance.

The power consumption of the aSC7511 is relatively low and should have little self-heating effect on the local sensor reading. At the highest measurement rate the dissipation is less than 2mW, resulting in only a few tenths of a degree rise.

Application Circuit

The aSC7511 may be used to turn a fan on and off in response to the internal or remote sensor. The active-low THERM pin offers a programmable turn-on temperature and the THERM hysteresis setting will turn the fan off.

An SMBus host is used to provide the settings for THERM and THERM hysteresis. The fan will come on when the THERM limit is reached and will turn off when it falls below THERM temperature by the amount set into the THERM hysteresis register. Figure 16 provides a circuit diagram.

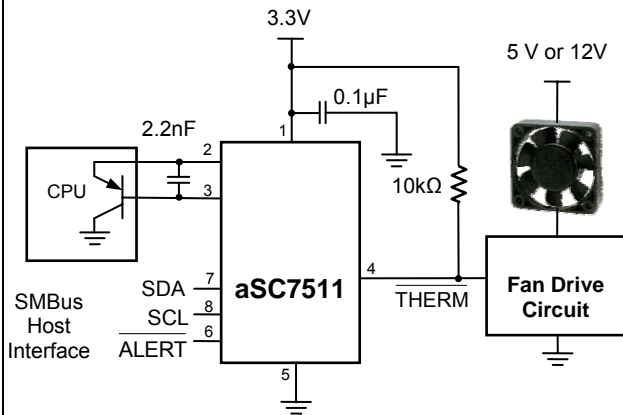

Figure 12. Simple Fan Control

Evaluation Board

The aSC7511EVB provides a platform for evaluation of the operational characteristics of the aSC7511. The board features a graphical user interface (GUI) to control and monitor all activities and readings of the aSC7511. The provided software will run on a Windows™-based desktop or laptop PC with a DB-25 parallel printer port.

Features:

- Interactive GUI for setting limits and operational configuration
- Powered and operated from PC parallel port
- LEDs for $\overline{\text{THERM}}$ and $\overline{\text{ALERT}}$ signals
- Graphical readout of temperature and alarms
- Selectable NPN or PNP sensor transistors
- Selectable remote diode connector
- Log file of readings
- Saving of setting configurations
- Optional use of external power and SMBus

D8 Package – 8-Lead SOP Package Dimensions

Pb-Free Package

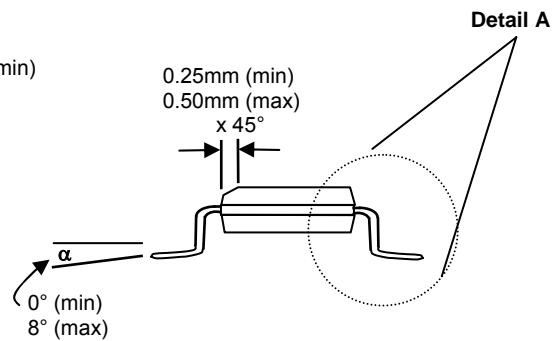
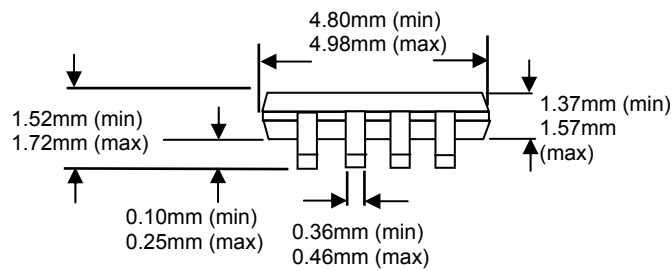
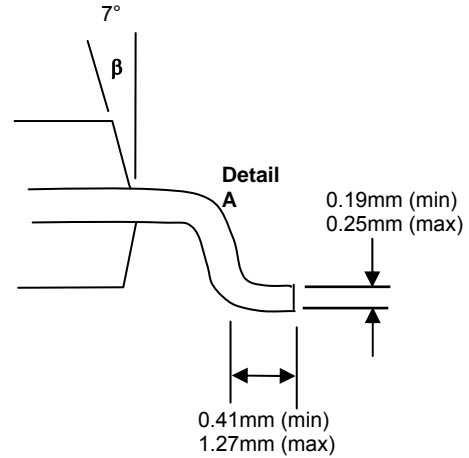
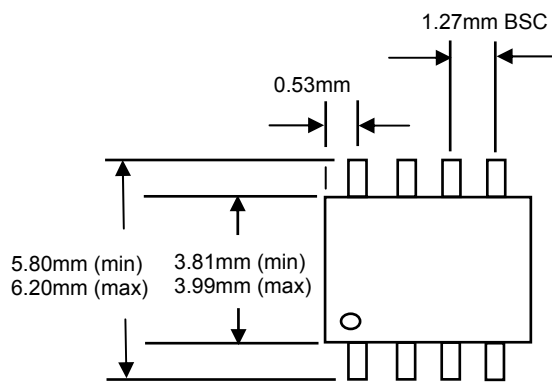

Preliminary Specification – Subject to change without notice

Preliminary Specification – Subject to change without notice

M8 Package – 8-Lead MSOP Package Dimensions

Pb-Free Package

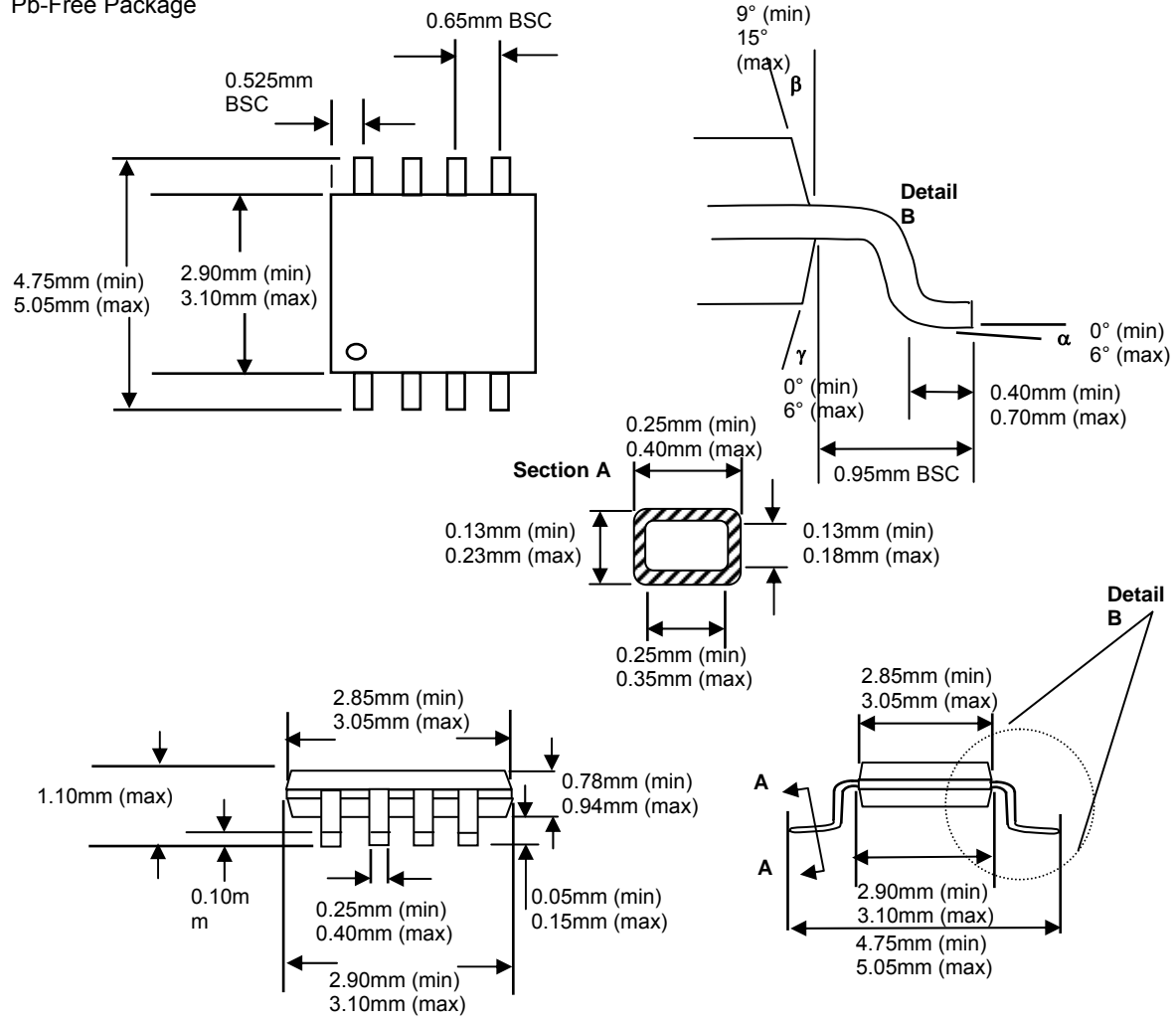

Data Sheet Classifications

Preliminary Specification

This classification is shown on the heading of each page of a specification for products that are either under development (design and qualification), or in the formative planning stages. Andigilog reserves the right to change or discontinue these products without notice.

New Release Specification

This classification is shown on the heading of the first page only of a specification for products that are either under the later stages of development (characterization and qualification), or in the early weeks of release to production. Andigilog reserves the right to change the specification and information for these products without notice.

Fully Released Specification

Fully released datasheets do not contain any classification in the first page header. These documents contain specification on products that are in full production. Andigilog will not change any guaranteed limits without written notice to the customers. Obsolete datasheets that were written prior to January 1, 2001 without any header classification information should be considered as obsolete and non-active specifications, or in the best case as Preliminary Specifications.

Andigilog® is a Registered Trademark of Andigilog, Inc.
Pentium™ is a trademark of Intel Corporation
Athlon™ and Duron™ are trademarks of AMD Corporation

LIFE SUPPORT POLICY

ANDIGILOG'S PRODUCTS ARE NOT AUTHORIZED FOR USE AS CRITICAL COMPONENTS IN LIFE SUPPORT DEVICES OR SYSTEMS WITHOUT THE EXPRESS WRITTEN APPROVAL OF THE PRESIDENT AND GENERAL COUNSEL OF ANDIGILOG, INC. As used herein:

1. Life support devices or systems are devices or systems which, (a) are intended for surgical implant into the body, or (b) support or sustain life, and whose failure to perform when properly used in accordance with instructions for use provided in the labeling, can be reasonably expected to result in a significant injury to the user.
2. A critical component is any component of a life support device or system whose failure to perform can be reasonably expected to cause the failure of the life support device or system, or to affect its safety or effectiveness.

Andigilog, Inc.
8380 S. Kyrene Rd., Suite 101
Tempe, Arizona 85284
Tel: (480) 940-6200
Fax: (480) 940-4255