

PLANAR TUNNEL (BACK) DIODE

DESCRIPTION:

The **ASTD** Series of Tunnel Diodes are Optimized for Operation as Back Diode Detectors in Applications up to 18 GHz.

FEATURES INCLUDE:

- Excellent Temperature Stability
- Fast Rise / Fall Times
- Available in Die Form

MAXIMUM RATINGS

I_R	10 mA
P_{DISS}	3 ERG spike
P_{DISS}	50 mW @ T _A = +60 °C
T_J	-65 to +110 °C
T_{STG}	-65 to +125 °C

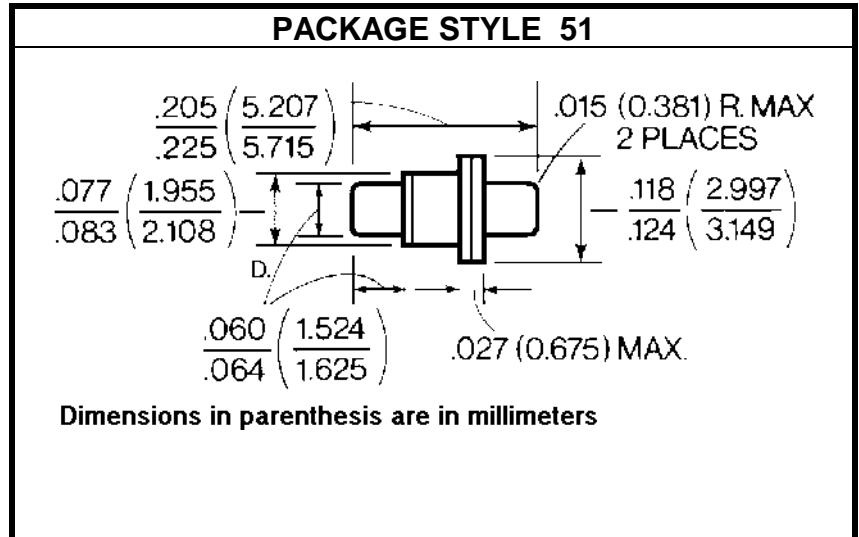
ELECTRICAL CHARACTERISTICS T_C = 25 °C

SYMBOL	TEST CONDITIONS	MINIMUM	TYPICAL	MAXIMUM	UNITS
I_P	ASTD 1020	100		200	μA
	ASTD 2030	200		300	
	ASTD 3040	300		400	
	ASTD 4050	400		500	
	ASTD 5060	500		600	
V_F	I _F = 3 mA			135	mV
	ASTD 1020			135	
	ASTD 2030			130	
	ASTD 3040			125	
	ASTD 4050			120	
V_R	I _R = 500 μA	400			mV



PLANAR TUNNEL (BACK) DIODE

DYNAMIC ELECTRICAL CHARACTERISTICS $T_C = 25\text{ }^\circ\text{C}$

Symbol	Test Conditions	Minimum	Typical	Maximum	Units
λ	F = 10 GHz $R_L = 10\text{ K}\Omega$ $P_{IN} = -20\text{ dBm}$	ASTD 1020	1,000		mV/mW
		ASTD 2030	750		
		ASTD 3040	500		
		ASTD 4050	275		
		ASTD 5060	250		
R_V	F = 10 GHz $R_L = 10\text{ K}\Omega$ $P_{IN} = -20\text{ dBm}$	ASTD 1020	180		Ω
		ASTD 2030	130		
		ASTD 3040	80		
		ASTD 4050	65		
		ASTD 5060	60		
R_S	$I_R = 10\text{ mA}$ F = 100 MHz			7.0	Ω

ORDERING INFORMATION:

ASTD-XXXX-XX

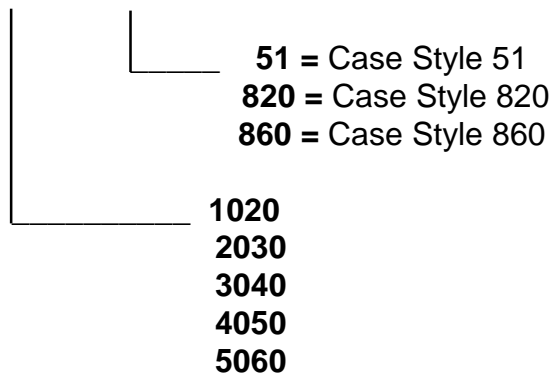

PLANAR TUNNEL (BACK) DIODE

