

# 4-Channel Video Decoder with Adaptive PAL/NTSC Comb Filter

## NVP1004

NVP1004 is the 4-Channel Video Decoder and delivers high quality images. It accepts separate 4 CVBS inputs from analog video signal sources like Camera, TV, VCR and so on. It digitizes and decodes NTSC/PAL video signal into digital components video which represents 8-bit CCIR656 4:2:2 format with 27MHz or 54MHz multiplexed. NVP1004 includes 4 channel analog processing circuits that comprise anti-aliasing filter, ADC, AGC and CLAMP. It shows the best picture quality adopted by highly performed 2D adaptive comb filter and vertical peaking filter. It also supports programmable Saturation, Hue, Brightness, Contrast and several functions such as CTI, Programmable peaking filter, PAL compensation, IF compensation filter and white peak detection. This submicron CMOS device is packaged in a 100TQFP. NVP1004 has 3 slave address pins for multi-chip applications.

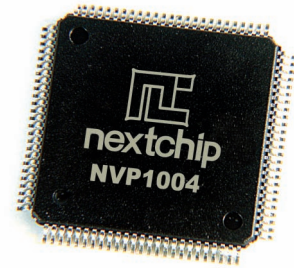

### Features

- 4-Channel Video Decoder which accepts 4 CVBS
- Output in CCIR656 4:2:2 format with 27MHz or 54MHz
- On Chip Analog CLAMP/AGC and Anti-aliasing Filter
- Accepts NTSC-M/J/4.43, PAL-M/N/B/D/G/H/I/60
- High-performance 3H/5H 2D adaptive comb filter
- Robust Sync detection for weak and non-standard signal
- Vertical Peaking filter
- Programmable brightness, contrast, saturation and hue
- White Peak Detection & Peak AGC
- CTI (Chrominance Transient Improvement)
- Programmable peaking filter for Luminance
- Color compensation for PAL
- IF compensation filter
- Robust No-video detection
- Motion Detection
- Low Power Consumption
- 100TQFP, 3.3V I/O, 1.8V Core power supply

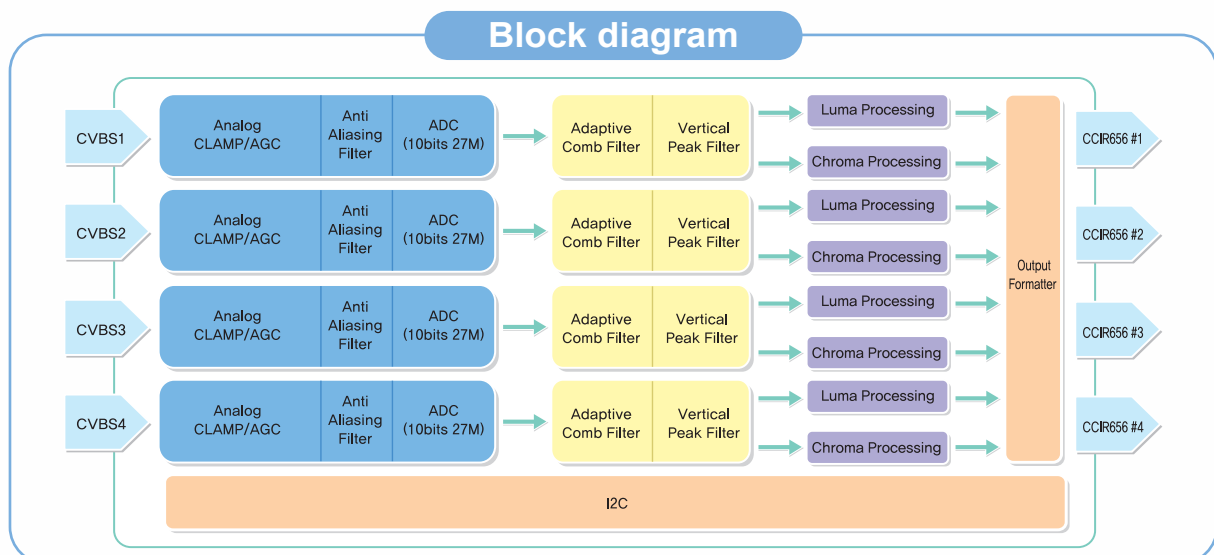

# Application Diagram

## Application 1: NVC1400 / NVC1401

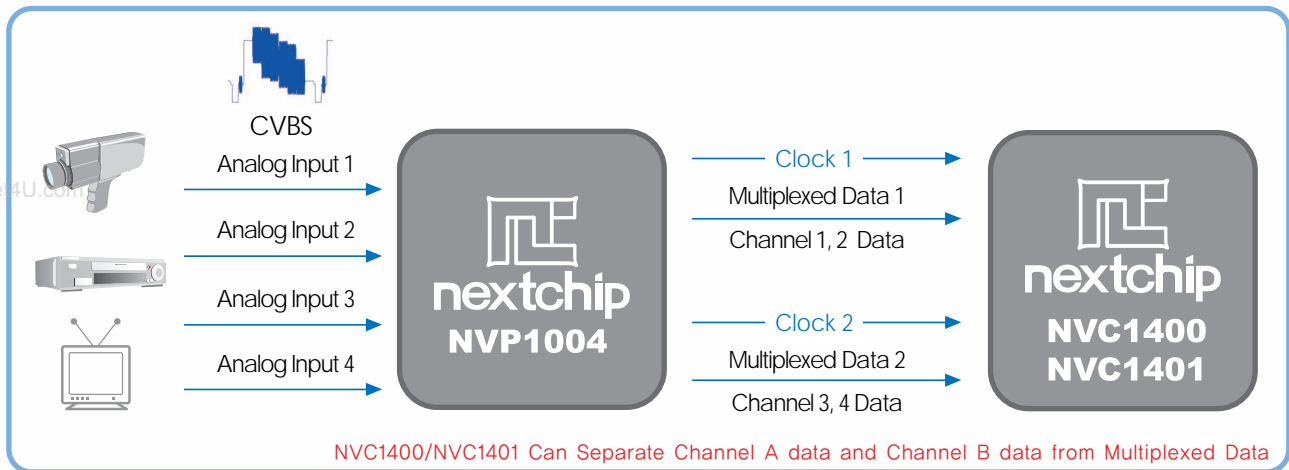

## Application 2 : Other Controller 1

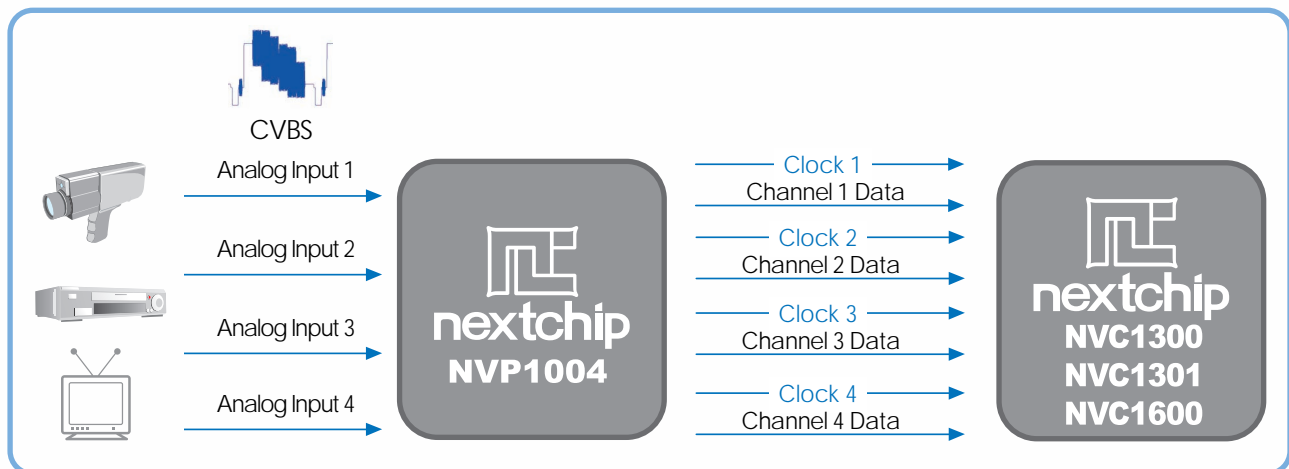

## Application 3 : Other Controller 2

