

# SN54LS465 THRU SN54LS468, SN74LS465 THRU SN74LS468 OCTAL BUFFERS WITH 3-STATE OUTPUTS

SDLS179 – JANUARY 1981 – REVISED MARCH 1988

- Mechanically and Functionally Interchangeable With DM71/81LS95 thru DM71/81LS98
- P-N-P Inputs Reduce Bus Loading
- 3-State Outputs Rated at  $I_{OL}$  of 12 mA and 24 mA for 54LS and 74LS, Respectively

DEVICE	DATA PATH
'LS465	True
'LS466	Inverting
'LS467	True
'LS468	Inverting

## description

These octal buffers utilize the latest low-power Schottky technology. The 'LS465 and 'LS466 have a two-input active-low AND enable gate controlling all eight data buffers. The 'LS467 and 'LS468 have two separate active-low enable inputs each controlling four data buffers. In either case, a high level on any  $\bar{G}$  places the affected outputs at high impedance.

## schematics of inputs and outputs

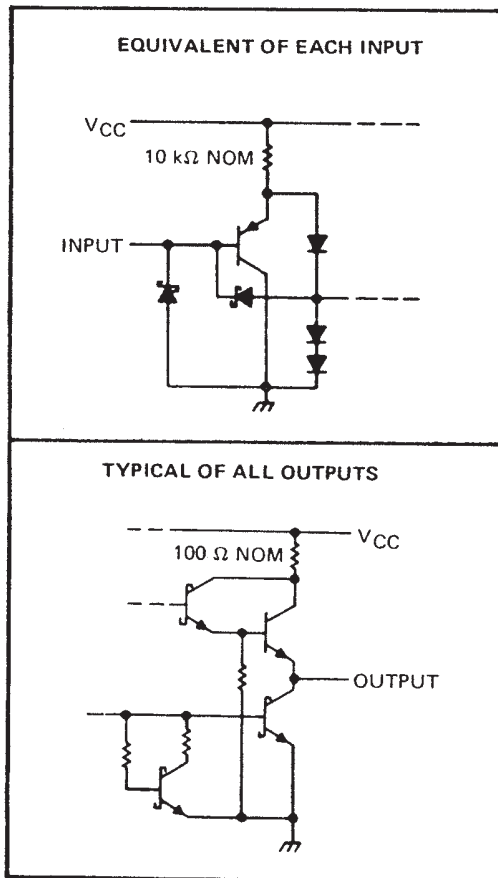

### SN54LS465 AND SN54LS466 . . . J PACKAGE SN74LS465 AND SN74LS466 . . . DW OR N PACKAGE

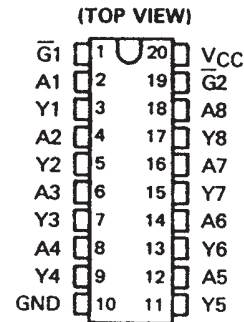

### SN54LS465 AND SN54LS466 . . . FK PACKAGE

(TOP VIEW)

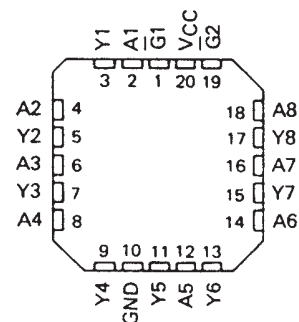

### SN54LS467 AND SN54LS468 . . . J PACKAGE SN74LS467 AND SN74LS468 . . . DW OR N PACKAGE

(TOP VIEW)

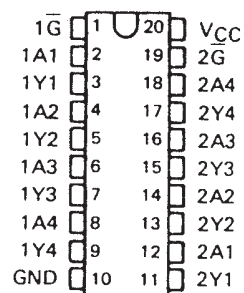

### SN54LS467 AND SN54LS468 . . . FK PACKAGE

(TOP VIEW)

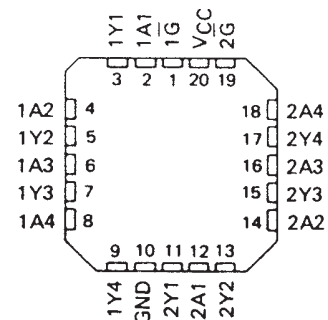

www.ti.com  
**SN54LS465 THRU SN54LS468, SN74LS465 THRU SN74LS468**  
**OCTAL BUFFERS WITH 3-STATE OUTPUTS**

SDLS179 – JANUARY 1981 – REVISED MARCH 1988

**logic diagrams (positive logic)**

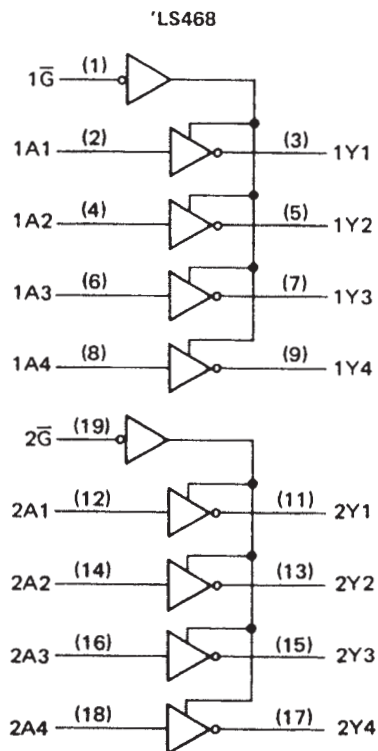
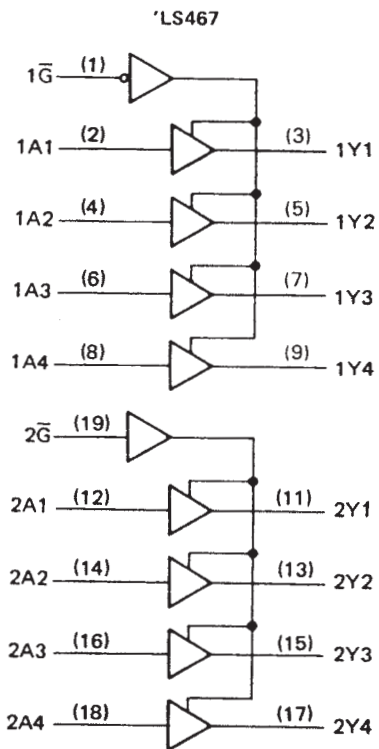
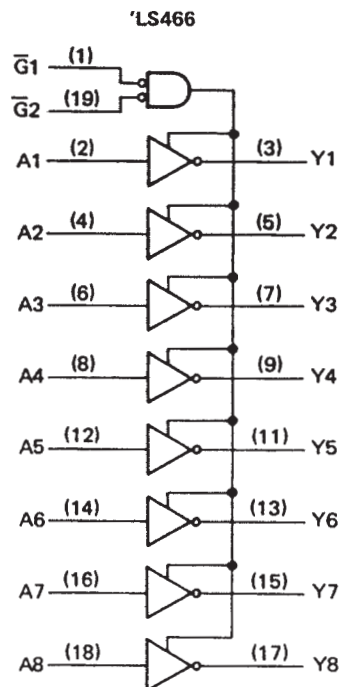
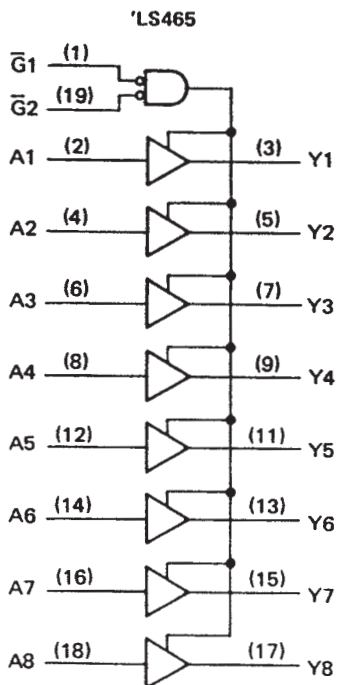

Pin numbers shown are for DW, J, and N packages.

logic symbols †

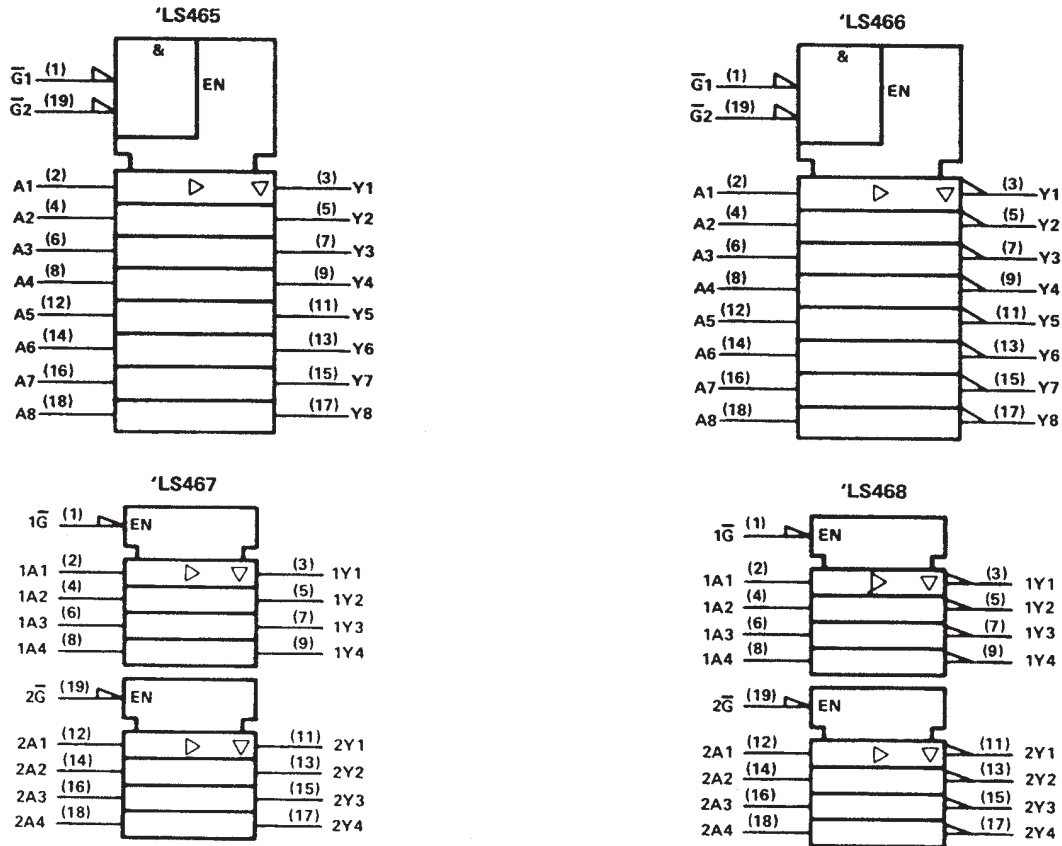

† These symbols are in accordance with ANSI/IEEE Std. 91-1984 and IEC Publication 617-12. Pin numbers shown are for DW, J, and N packages.

absolute maximum ratings over operating free-air temperature range (unless otherwise noted)

Supply voltage, $V_{CC}$ (see Note 1)	7 V
Input voltage	7 V
Off-state output voltage	5.5 V
Operating free-air temperature range: SN54LS465 thru SN54LS468	-55°C to 125°C
SN74LS465 thru SN74LS468	0°C to 70°C
Storage temperature range	-65°C to 150°C

NOTE 1: Voltage values are with respect to the network ground terminal.

recommended operating conditions

	SN54LS'			SN74LS'			UNIT
	MIN	NOM	MAX	MIN	NOM	MAX	
Supply voltage, $V_{CC}$	4.5	5	5.5	4.75	5	5.25	V
High-level output current, $I_{OH}$			-1			-2.6	mA
Low-level output current, $I_{OL}$			12			24	mA
Operating free-air temperature, $T_A$	-55		125	0		70	°C

# SN54LS465 THRU SN54LS468, SN74LS465 THRU SN74LS468

## OCTAL BUFFERS WITH 3-STATE OUTPUTS

SDLS179 – JANUARY 1981 – REVISED MARCH 1988

electrical characteristics over recommended operating free-air temperature range (unless otherwise noted)

PARAMETER	TEST CONDITIONS†	SN54LS'			SN74LS'			UNIT	
		MIN	TYP‡	MAX	MIN	TYP‡	MAX		
V <sub>IH</sub> High-level input voltage		2			2			V	
V <sub>IL</sub> Low-level input voltage				0.7			0.8	V	
V <sub>IK</sub> Input clamp voltage	V <sub>CC</sub> = MIN, I <sub>I</sub> = -18 mA			-1.5			-1.5	V	
V <sub>OH</sub> High-level output voltage	V <sub>CC</sub> = MIN, V <sub>IH</sub> = 2 V, V <sub>IL</sub> = V <sub>IL</sub> max	I <sub>OH</sub> = -1 mA						V	
		I <sub>OH</sub> = -2.6 mA			2.4 3.1				
V <sub>OL</sub> Low-level output voltage	V <sub>CC</sub> = MIN, V <sub>IH</sub> = 2 V, V <sub>IL</sub> = V <sub>IL</sub> max	I <sub>OL</sub> = 12 mA			0.25 0.4			V	
		I <sub>OL</sub> = 24 mA			0.25 0.4				
I <sub>OZH</sub> Off-state output current, high-level voltage applied	V <sub>CC</sub> = MAX, V <sub>IH</sub> = 2 V, V <sub>IL</sub> = V <sub>IL</sub> max, V <sub>O</sub> = 2.7 V			20			20	μA	
I <sub>OZL</sub> Off-state output current, low-level voltage applied	V <sub>CC</sub> = MAX, V <sub>IH</sub> = 2 V, V <sub>IL</sub> = V <sub>IL</sub> max, V <sub>O</sub> = 0.4 V			-20			-20	μA	
I <sub>I</sub> Input current at maximum input voltage	V <sub>CC</sub> = MAX, V <sub>I</sub> = 7 V			0.1			0.1	mA	
I <sub>IH</sub> High-level input current	V <sub>CC</sub> = MAX, V <sub>I</sub> = 2.7 V			20			20	μA	
I <sub>IL</sub> Low-level input current	V <sub>CC</sub> = MAX, V <sub>I</sub> = 0.4 V			-0.2			-0.2	mA	
I <sub>OS</sub> Short-circuit output current§	V <sub>CC</sub> = MAX, V <sub>O</sub> = 0 V			-30		-130	-30	-130	mA
I <sub>CC</sub> Supply current	V <sub>CC</sub> = MAX		Outputs low	19	32	19	32	mA	
			Outputs high	13	22	13	22		
			Output Hi-Z	22	37	22	37		
			Outputs low	14	23	14	23		
			Outputs high	6	10	6	10		
			Outputs Hi-Z	17	28	17	28		

† For conditions shown as MIN or MAX, use the appropriate value specified under recommended operating conditions.

‡ All typical values are at V<sub>CC</sub> = 5 V, T<sub>A</sub> = 25°C.

§ Not more than one output should be shorted at a time, and duration of the short-circuit should not exceed one second.

switching characteristics, V<sub>CC</sub> = 5 V, T<sub>A</sub> = 25°C, see note 2

PARAMETER	FROM (INPUT)	TO (OUTPUT)	TEST CONDITIONS	'LS465, 'LS467			'LS466, 'LS468			UNIT
				MIN	TYP	MAX	MIN	TYP	MAX	
t <sub>PLH</sub>	A <sub>i</sub>	Y <sub>i</sub>	R <sub>L</sub> = 667 Ω, C <sub>L</sub> = 45 pF		9	15		7	12	ns
t <sub>PHL</sub>	A <sub>i</sub>	Y <sub>i</sub>			12	18		9	15	ns
t <sub>PZH</sub>	$\bar{G}$ ↓	Y			25	40		25	40	ns
t <sub>PZL</sub>	$\bar{G}$ ↓	Y			29	45		29	45	ns
t <sub>PHZ</sub>	$\bar{G}$ ↑	Y	R <sub>L</sub> = 667 Ω, C <sub>L</sub> = 5 pF		25	40		25	40	ns
t <sub>PLZ</sub>	$\bar{G}$ ↑	Y			30	45		30	45	ns

NOTE 2: Load circuits and voltage waveforms are shown in Section 1.

### IMPORTANT NOTICE

Texas Instruments and its subsidiaries (TI) reserve the right to make changes to their products or to discontinue any product or service without notice, and advise customers to obtain the latest version of relevant information to verify, before placing orders, that information being relied on is current and complete. All products are sold subject to the terms and conditions of sale supplied at the time of order acknowledgement, including those pertaining to warranty, patent infringement, and limitation of liability.

TI warrants performance of its semiconductor products to the specifications applicable at the time of sale in accordance with TI's standard warranty. Testing and other quality control techniques are utilized to the extent TI deems necessary to support this warranty. Specific testing of all parameters of each device is not necessarily performed, except those mandated by government requirements.

CERTAIN APPLICATIONS USING SEMICONDUCTOR PRODUCTS MAY INVOLVE POTENTIAL RISKS OF DEATH, PERSONAL INJURY, OR SEVERE PROPERTY OR ENVIRONMENTAL DAMAGE ("CRITICAL APPLICATIONS"). TI SEMICONDUCTOR PRODUCTS ARE NOT DESIGNED, AUTHORIZED, OR WARRANTED TO BE SUITABLE FOR USE IN LIFE-SUPPORT DEVICES OR SYSTEMS OR OTHER CRITICAL APPLICATIONS. INCLUSION OF TI PRODUCTS IN SUCH APPLICATIONS IS UNDERSTOOD TO BE FULLY AT THE CUSTOMER'S RISK.

In order to minimize risks associated with the customer's applications, adequate design and operating safeguards must be provided by the customer to minimize inherent or procedural hazards.

TI assumes no liability for applications assistance or customer product design. TI does not warrant or represent that any license, either express or implied, is granted under any patent right, copyright, mask work right, or other intellectual property right of TI covering or relating to any combination, machine, or process in which such semiconductor products or services might be or are used. TI's publication of information regarding any third party's products or services does not constitute TI's approval, warranty or endorsement thereof.

Copyright © 1999, Texas Instruments Incorporated