

STRUCTURE Silicon Monolithic Integrated Circuit
 PRODUCT CMOS-type Series Regulator

NAME B U x x T A 2 W H F V Series

○ BLOCK DIAGRAM and APPLICATION CIRCUIT

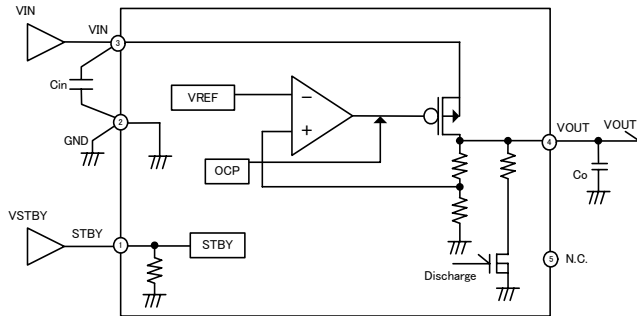

PIN No.	PIN NAME	DESCRIPTION
1	STBY	OUTPUT CONTROL Pin (High: ON, Low: OFF)
2	GND	GROUND Pin
3	VIN	INPUT Pin
4	VOUT	OUTPUT Pin
5	N. C.	No Connect

$C_{in} \cdots 1.0 \mu F$ (Ceramic)

$C_o \cdots 1.0 \mu F$ (Ceramic)

Fig.1 BLOCK DIAGRAM and APPLICATION CIRCUIT

○ ABSOLUTE MAXIMUM RATINGS ($T_a = 25^\circ C$)

PARAMETER	Symbol	Limit	Unit
Power Supply Voltage	VMAX	-0.3 ~ +6.5	V
Power Dissipation	Pd	410 (*1)	mW
Maximum junction temperature	TjMAX	+125	$^\circ C$
Operating Temperature Range	Topr	-40 ~ +85	$^\circ C$
Storage Temperature Range	Tstg	-55 ~ +125	$^\circ C$

(*1) Pd derated at $4.1 \text{ mW}/^\circ C$ at temperatures above $T_a = 25^\circ C$,
 mounted on $70 \times 70 \times 1.6 \text{ mm}$ glass-epoxy PCB.

○ RECOMMENDED OPERATING RANGE (not to exceed Pd)

PARAMETER	Symbol	Limit	Unit
Power Supply Voltage	VIN	2.5 ~ 5.5	V
Maximum Output Current	IMAX	200	mA

Status of this document

The Japanese version of this document is the official specification.

Please use the translation version of this document as a reference to expedite understanding of the official version.

If there is any uncertainty in translation version of this document, official version takes priority.

● OPERATING CONDITIONS

PARAMETER	Symbol	MIN.	TYP.	MAX.	Unit	CONDITION
Input Capacitor	Cin	0.5(*2)	1.0	–	μF	Ceramic capacitor recommended
Output Capacitor	Co	0.5(*2)	1.0	–	μF	

(*2) Make sure that the output capacitor value is not kept lower than this specified level across a variety of temperature, DC bias, changing as time progresses characteristic.

● ELECTRICAL CHARACTERISTICS

(Ta=25°C, VIN= VOUT + 1.0 V (VOUT=1.5V, 1.8V, 2.3V : VIN=3.5V), STBY=1.5 V, Ci=1.0 μF, Co=1.0 μF, unless otherwise noted.)

PARAMETER	Symbol	Limit			Unit	Conditions	
		MIN.	TYP.	MAX.			
Overall Device							
Output Voltage	VOUT	VOUT × 0.99	VOUT	VOUT × 1.01	V	IOUT=10 μA, VOUT ≥ 2.5V	
		VOUT-25mV		VOUT+25mV		IOUT=10 μA, VOUT < 2.5V	
Operating Current	IIN	–	40	95	μA	IOUT=0mA	
Operating Current (STBY)	ISTBY	–	–	1	μA	STBY=0V	
Ripple Rejection Ratio	RR	55	70	–	dB	VRR=-20dBv, fRR=1kHz, IOUT=10mA 1.5V ≤ VOUT ≤ 1.8V	
			65			VRR=-20dBv, fRR=1kHz, IOUT=10mA 2.3V ≤ VOUT	
Dropout Voltage	VSAT	–	450	900	mV	VOUT=2.3V (VIN=0.98×VOUT, IOUT=200mA)	
		–	400	800	mV	2.5V ≤ VOUT ≤ 2.6V (VIN=0.98×VOUT, IOUT=200mA)	
		–	360	720	mV	2.7V ≤ VOUT ≤ 2.85V (VIN=0.98×VOUT, IOUT=200mA)	
		–	330	660	mV	2.9V ≤ VOUT ≤ 3.1V (VIN=0.98×VOUT, IOUT=200mA)	
		–	300	600	mV	3.2V ≤ VOUT ≤ 3.4V (VIN=0.98×VOUT, IOUT=200mA)	
Line Regulation	VDL	–	2	20	mV	VIN=VOUT+1.0V to 5.5V, IOUT=10 μA	
Load Regulation	VDLO	–	10	80	mV	IOUT=0.01mA to 100mA	
Over-current Protection (OCP)							
Limit Current	ILMAX	220	350	700	mA	Vo=VOUT×0.8	
Short Current	ISHORT	20	70	150	mA	Vo=0V	
Standby Block							
Discharge Resistor	RDSC	20	50	80	Ω	VIN=4.0V, STBY=0V	
STBY Pin Pull-down Resistor	RSTB	500	1000	2000	kΩ		
Control Voltage	ON	VSTBH	1.5	–	5.5	V	Output Voltage ON
	OFF	VSTBL	-0.3	–	0.3	V	Output Voltage OFF

● This product is not designed for protection against radioactive rays.

○ Power Dissipation Curves

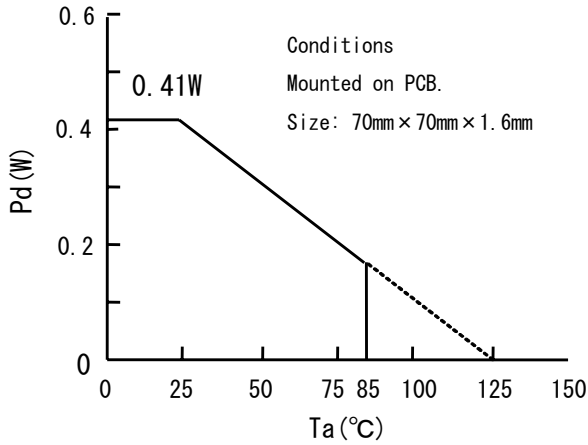

Fig.2 Pd reduction (example)

Pd is changed by mount condition.
Please refer the technical note about more detailed information of Pd.

○ Device Name and Marking

Device Name: **BUXXTA2WHFV**



symbol	Description		Marking
	XX	Output Voltage	
a	15	1.5V typ.	BA
	18	1.8V typ.	BB
	23	2.3V typ.	BC
	25	2.5V typ.	BD
	26	2.6V typ.	BE
	27	2.7V typ.	BF
	28	2.8V typ.	BG
	2J	2.85V typ.	BH
	29	2.9V typ.	BJ
	30	3.0V typ.	BK
	31	3.1V typ.	BL
	32	3.2V typ.	BM
	33	3.3V typ.	BN
	34	3.4V typ.	BP

○ Package dimensions (HVS0F5)

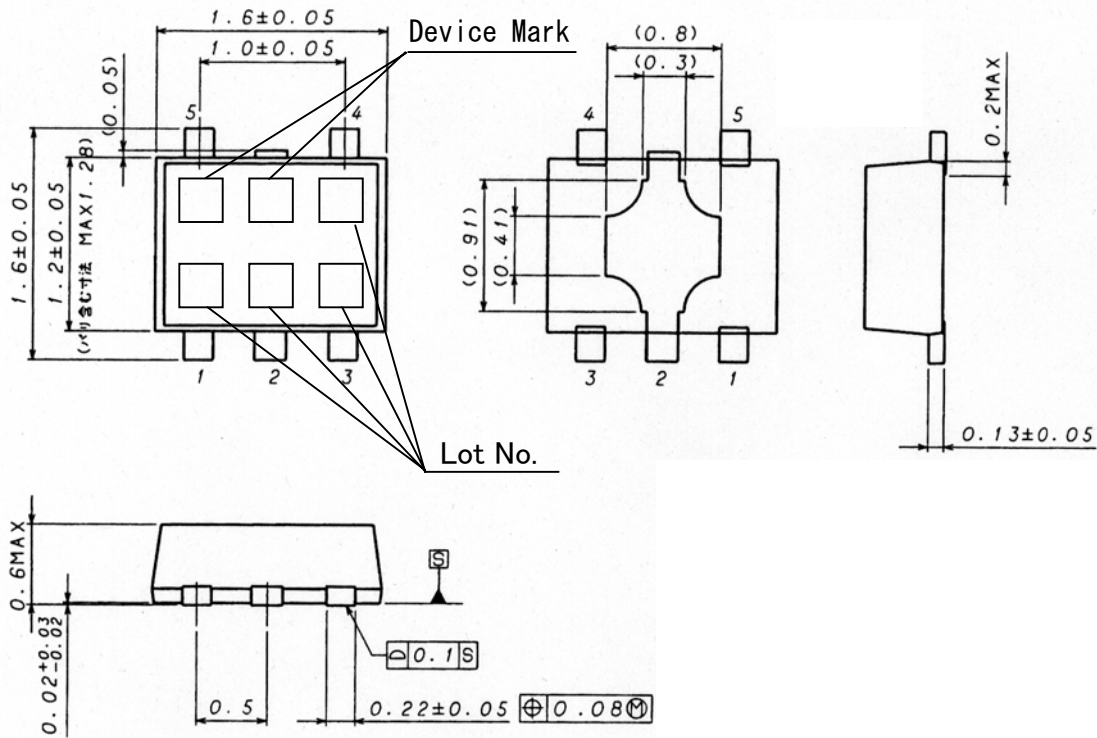

Fig.3 Package dimensions (Unit: mm)

Operation Notes

1.) Absolute maximum ratings

Use of the IC in excess of absolute maximum ratings (such as the input voltage or operating temperature range) may result in damage to the IC. Assumptions should not be made regarding the state of the IC (e.g., short mode or open mode) when such damage is suffered. If operational values are expected to exceed the maximum ratings for the device, consider adding protective circuitry (such as fuses) to eliminate the risk of damaging the IC.

2.) GND potential

The potential of the GND pin must be the minimum potential in the system in all operating conditions. Never connect a potential lower than GND to any pin, even if only transiently.

3.) Thermal design

Use a thermal design that allows for a sufficient margin for that package power dissipation rating (Pd) under actual operating conditions.

4.) Inter-pin shorts and mounting errors

Use caution when orienting and positioning the IC for mounting on printed circuit boards. Improper mounting or shorts between pins may result in damage to the IC.

5.) Operation in strong electromagnetic fields

Strong electromagnetic fields may cause the IC to malfunction. Caution should be exercised in applications where strong electromagnetic fields may be present.

6.) Common impedance

Wiring traces should be as short and wide as possible to minimize common impedance. Bypass capacitors should be used to keep ripple to a minimum.

7.) Voltage of STBY pin

To enable standby mode for all channels, set the STBY pin to 0.3 V or less, and for normal operation, to 1.5 V or more. Setting STBY to a voltage between 0.3 and 1.5 V may cause malfunction and should be avoided. Keep transition time between high and low (or vice versa) to a minimum.

Additionally, if STBY is shorted to VIN, the IC will switch to standby mode and disable the output discharge circuit, causing a temporary voltage to remain on the output pin. If the IC is switched on again while this voltage is present, overshoot may occur on the output. Therefore, in applications where these pins are shorted, the output should always be completely discharged before turning the IC on.

8.) Over-current protection circuit (OCP)

This IC features an integrated over-current and short-protection circuitry on the output to prevent destruction of the IC when the output is shorted. The OCP circuitry is designed only to protect the IC from irregular conditions (such as motor output shorts) and is not designed to be used as an active security device for the application. Therefore, applications should not be designed under the assumption that this circuitry will engage.

9.) Thermal shutdown circuit (TSD)

This IC also features a thermal shutdown circuit that is designed to turn the output off when the junction temperature of the IC exceeds 175°C. This feature is intended to protect the IC only in the event of thermal overload and is not designed to guarantee operation or act as an active security device for the application. Therefore, applications should not be designed under the assumption that this circuitry will engage.

10.) Input/output capacitor

Capacitors must be connected between the input/output pins and GND for stable operation, and should be physically mounted as close to the IC pins as possible (refer to figure 4). The input capacitor helps to counteract increases in power supply impedance, and increases stability in applications with long or winding power supply traces. The output capacitance value is directly related to the overall stability and transient response of the regulator, and should be set to the largest possible value for the application to increase these characteristics. During design, keep in mind that in general, ceramic capacitors have a wide range of tolerances, temperature coefficients and DC bias characteristics, and that their capacitance values tend to decrease over time. Confirm these details before choosing appropriate capacitors for your application. (Please refer the technical note, regarding ceramic capacitor of recommendation)

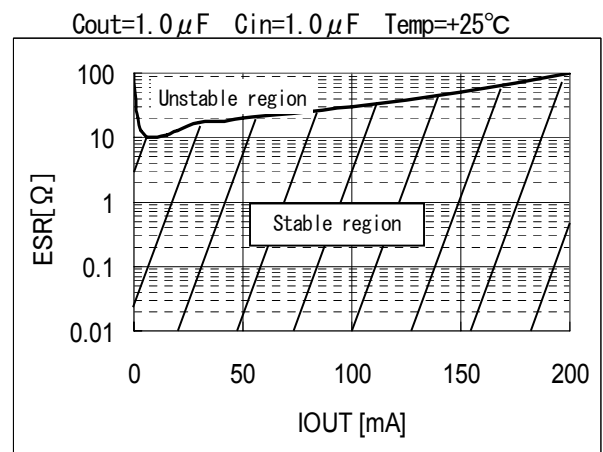

Fig. 4 Stable region (example)