



# 3-Axis, Digital Magnetometer

Freescale's MAG3110 is a small, low-power, digital 3-axis magnetometer.

The device can be used in conjunction with a 3-axis accelerometer to produce orientation independent accurate compass heading information. It features a standard I<sup>2</sup>C serial interface output and smart embedded functions.

The MAG3110 is capable of measuring magnetic fields with an Output Data Rate (ODR) up to 80 Hz; these output data rates correspond to sample intervals from 12 ms to several seconds.

The MAG3110 is available in a plastic DFN package and it is guaranteed to operate over the extended temperature range of -40°C to +85°C.

## Features

- 1.95V to 3.6V Supply Voltage (VDD)
- 1.65V to VDD IO Voltage (VDDIO)
- Ultra Small 2 mm x 2 mm x 0.85 mm, 0.4 mm Pitch, 10 Pin Package
- Full Scale Range ±1000 μT
- Sensitivity of 0.10 μT
- Noise down to 0.05 μT rms
- Output Data Rates (ODR) up to 80 Hz
- I<sup>2</sup>C digital output interface (operates up to 400 kHz Fast Mode)
- 7-bit I<sup>2</sup>C address = 0x0E
- Sampled Low Power Mode
- RoHS compliant

## Applications

- Electronic Compass
- Dead-reckoning assistance for GPS backup
- Location-based Services

## MAG3110

### MAG3110: 3-AXIS DIGITAL MAGNETOMETER

#### Top and Bottom View



10 PIN DFN  
2 mm x 2 mm x 0.85 mm  
CASE 2154

#### Top View

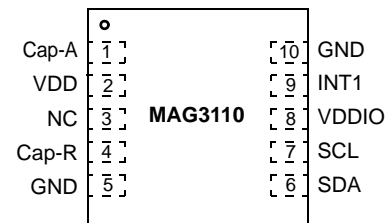

#### Pin Connections

## ORDERING INFORMATION

Part Number	Temperature Range	Package Description	Shipping
MAG3110FCR2	-40°C to +85°C	DFN-10	Tape and Reel

## Application Notes for Reference

The following is a list of Freescale Application Notes written for the MAG3110:

- **AN4246**, *Calibrating for Soft Iron and Hard Iron Distortions*
- **AN4247**, *PCB Layout Guidelines and Recommendations*
- **AN4248**, *Using the MAG3110 Magnetometer for an eCompass Application*
- **AN4249**, *Using the MAG3110 Magnetometer to Implement a 3-D Pointer*

# 1 Block Diagram and Pin Description

## 1.1 Block Diagram

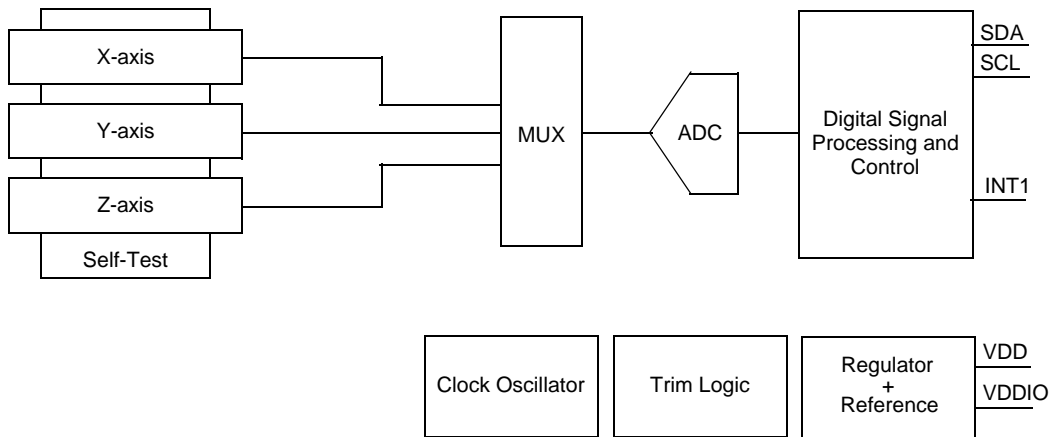

Figure 1. Block Diagram

## 1.2 Pin Description

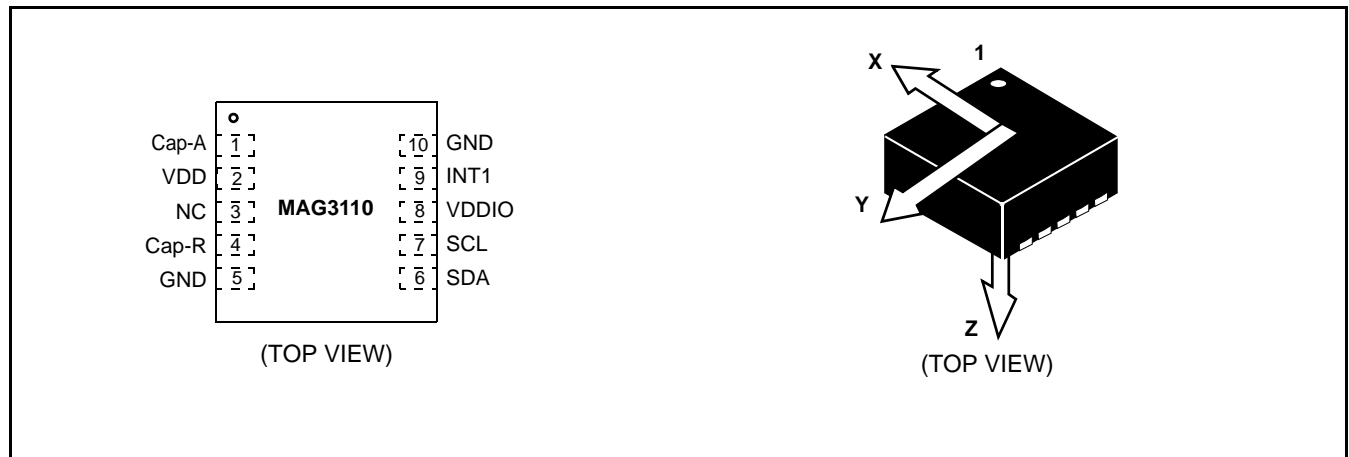

Figure 2. Pin Connections

Figure 3. Measurement Coordinate System

**Table 1. Pin Description**

Pin	Name	Function
1	Cap-A	Bypass Cap for Internal Regulator
2	VDD	Power Supply, 1.95V – 3.6V
3	NC	No Connect – do not connect
4	Cap-R	Cap for Reset Pulse
5	GND	GND
6	SDA	I <sup>2</sup> C Serial Data (Write = 0x1C; Read = 0x1D)
7	SCL	I <sup>2</sup> C Serial Clock
8	VDDIO	Power for I/O Buffers, 1.65V - VDD
9	INT1	Interrupt - Active High Output
10	GND	GND

### 1.3 Application Circuit

The device power is supplied through VDD line. Power supply decoupling capacitors (100 nF ceramic) should be placed as near as possible to pins 1 and 2 of the device. VDDIO supplies power for the I/O pins SCL, SDA, and INT1.

The control signals SCL and SDA, are not tolerant of voltages more than VDDIO + 0.3 volts. If VDDIO is removed, the control signals SCL and SDA will clamp any logic signals with their internal ESD protection diodes.

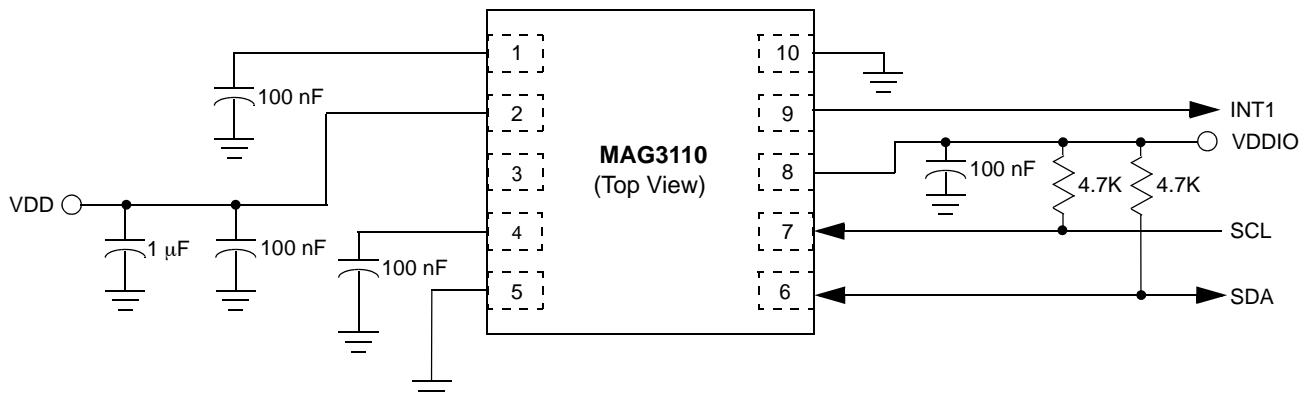

**Figure 4. Electrical Connection**

## 2 Operating and Electrical Specifications

### 2.1 Operating Characteristics

Table 2. Operating Characteristics @ VDD = 1.8 V, T = 25°C unless otherwise noted.

Parameter	Test Conditions	Symbol	Min	Typ	Max	Unit
Full Scale Range		FS		±1000		μT
Output Data Range (RAW = 1)			-15,000		15,000	bits
Output Data Range (RAW = 0)			-30,000		30,000	bits
Sensitivity		So		0.10		μT/bits
Sensitivity Change vs. Temperature		Tc		±0.1		%/°C
Zero Flux Offset Accuracy				±500		μT
Zero Flux Change with Temperature		Tco		±0.01		μT/°C
Hysteresis					1	%
Non Linearity Best Fit Straight Line		NL	-1	±0.3	1	%FS
Temp Sensor Repeatability				1		°C
Magnetometer Output Noise	OS = 00 <sup>(1)</sup>	Noise		0.14		μT rms
	OS = 01			0.1		
	OS = 10			0.07		
	OS = 11			0.05		
Self-test Output Change <sup>(2)</sup> X-axis Y-axis Z-axis		Vst	20			LSB
			20			LSB
			20			LSB
Operating Temperature Range		T <sub>op</sub>	-40		+85	°C

1. OS = Over Sampling Ratio.

2. Self-test is one direction only.

### 2.2 Absolute Maximum Ratings

Stresses above those listed as “absolute maximum ratings” may cause permanent damage to the device. This is a stress rating only and functional operation of the device under these conditions is not implied. Exposure to maximum rating conditions for extended periods may affect device reliability.

Table 3. Maximum Ratings

Rating	Symbol	Value	Unit
Supply Voltage	VDD	-0.3 to +3.6	V
Input Voltage on any Control Pin (SCL, SDA)	V <sub>in</sub>	-0.3 to VDD + 0.3	V
Maximum Applied Magnetic Field	—	100,000	μT
Operating Temperature Range	T <sub>op</sub>	-40 to +85	°C
Storage Temperature Range	T <sub>STG</sub>	-40 to +125	°C

Table 4. ESD and Latch-up Protection Characteristics

Rating	Symbol	Value	Unit
Human Body Model	HBM	±2000	V
Machine Model	MM	±200	V
Charge Device Model	CDM	±500	V
Latch-up Current at T = 85°C	—	±100	mA



This device is sensitive to mechanical shock. Improper handling can cause permanent damage of the part or cause the part to otherwise fail.



This is an ESD sensitive, improper handling can cause permanent damage to the part.

## 2.3 Electrical Characteristics

**Table 5. Electrical Characteristics @ VDD = 2.0V, VDDIO = 1.8V, T = 25°C unless otherwise noted**

Parameter	Test Conditions	Symbol	Min	Typ	Max	Unit
Supply Voltage		VDD	1.95	2.4	3.6	V
Interface Supply Voltage		VDDIO	1.62		VDD	V
Supply Current in ACTIVE Mode	ODR <sup>(1)</sup> 10 Hz, OS <sup>(1)</sup> = 11	I <sub>dd</sub>		900		μA
	ODR 10 Hz, OS = 10			480		
	ODR 10 Hz, OS = 01			280		
	ODR 10 Hz, OS = 00			140		
	ODR 5 Hz, OS = 00			70		
	ODR 1.25 Hz, OS = 00			24		
Supply Current Drain in STANDBY Mode	Measurement mode off	I <sub>ddStby</sub>		2		μA
Digital High Level Input Voltage SCL, SDA		VIH	0.75*VDDIO			V
Digital Low Level Input Voltage SCL, SDA		VIL			0.3* VDDIO	V
High Level Output Voltage INT1	I <sub>O</sub> = 500 μA	VOH	0.9*VDDIO			V
Low Level Output Voltage INT1	I <sub>O</sub> = 500 μA	VOL			0.1* VDDIO	V
Low Level Output Voltage SDA	I <sub>O</sub> = 500 μA	VOLS			0.1* VDDIO	V
Output Data Rate (ODR)		ODR	0.8*ODR	ODR	1.2 *ODR	Hz
Signal Bandwidth		BW		ODR/2		Hz
Boot Time from Power applied to Boot Complete		BT			10	ms
Turn-on Time <sup>(2)</sup>	OS = 1	T <sub>on</sub>		25		ms
Operating Temperature Range		T <sub>op</sub>	-40		+85	°C

1. ODR = Output Data Rate; OS = Over Sampling Ratio.

2. Time to obtain valid data from STANDBY mode to ACTIVE Mode.

## 2.4 I<sup>2</sup>C Interface Characteristics

Table 6. I<sup>2</sup>C Slave Timing Values<sup>(1)</sup>

Parameter	Symbol	I <sup>2</sup> C Fast Mode		Unit
		Min	Max	
SCL Clock Frequency Pull-up = 1 kΩ, C <sub>b</sub> = 20 pF Pull-up = 1 kΩ, C <sub>b</sub> = 400 pF	f <sub>SCL</sub>	0 0	400 TBD	kHz kHz
Bus Free Time between STOP and START Condition	t <sub>BUF</sub>	1.3		μs
Repeated START Hold Time	t <sub>HD;STA</sub>	0.6		μs
Repeated START Set-up Time	t <sub>SU;STA</sub>	0.6		μs
STOP Condition Set-up Time	t <sub>SU;STO</sub>	0.6		μs
SDA Data Hold Time <sup>(2)</sup>	t <sub>HD;DAT</sub>	50 <sup>(3)</sup>	<sup>(4)</sup>	μs
SDA Valid Time <sup>(5)</sup>	t <sub>VD;DAT</sub>		0.9 <sup>(4)</sup>	μs
SDA Valid Acknowledge Time <sup>(6)</sup>	t <sub>VD;ACK</sub>		0.9 <sup>(4)</sup>	μs
SDA Set-up Time	t <sub>SU;DAT</sub>	100 <sup>(7)</sup>		ns
SCL Clock Low Time	t <sub>LOW</sub>	1.3		μs
SCL Clock High Time	t <sub>HIGH</sub>	0.6		μs
SDA and SCL Rise Time	t <sub>r</sub>	20 + 0.1C <sub>b</sub> <sup>(8)</sup>	1000	ns
SDA and SCL Fall Time <sup>(3) (8) (9) (10)</sup>	t <sub>f</sub>	20 + 0.1C <sub>b</sub> <sup>(8)</sup>	300	ns
Pulse width of spikes on SDA and SCL that must be suppressed by input filter	t <sub>SP</sub>		50	ns

- All values referred to VIH (min) and VIL (max) levels.
- t<sub>HD;DAT</sub> is the data hold time that is measured from the falling edge of SCL, applies to data in transmission and the acknowledge.
- A device must internally provide a hold time of at least 300 ns for the SDA signal (with respect to the VIH (min) of the SCL signal) to bridge the undefined region of the falling edge of SCL.
- The maximum t<sub>HD;DAT</sub> could be must be less than the maximum of t<sub>VD;DAT</sub> or t<sub>VD;ACK</sub> by a transition time. This device does not stretch the LOW period (t<sub>LOW</sub>) of the SCL signal.
- t<sub>VD;DAT</sub> = time for Data signal from SCL LOW to SDA output (HIGH or LOW, depending on which one is worse).
- t<sub>VD;ACK</sub> = time for Acknowledgement signal from SCL LOW to SDA output (HIGH or LOW, depending on which one is worse).
- A Fast mode I<sup>2</sup>C device can be used in a Standard mode I<sup>2</sup>C system, but the requirement t<sub>SU;DAT</sub> 250 ns must then be met. This will automatically be the case if the device does not stretch the LOW period of the SCL signal. If such a device does stretch the LOW period of the SCL signal, it must output the next data bit to the SDA line t<sub>r(max)</sub> + t<sub>SU;DAT</sub> = 1000 + 250 = 1250 ns (according to the Standard mode I<sup>2</sup>C specification) before the SCL line is released. Also the acknowledge timing must meet this set-up time
- C<sub>b</sub> = total capacitance of one bus line in pF.
- The maximum t<sub>r</sub> for the SDA and SCL bus lines is specified at 300 ns. The maximum fall time for the SDA output stage t<sub>f</sub> is specified at 250 ns. This allows series protection resistors to be connected in between the SDA and the SCL pins and the SDA/SCL bus lines without exceeding the maximum specified t<sub>r</sub>.
- In Fast mode Plus, fall time is specified the same for both output stage and bus timing. If series resistors are used, designers should allow for this when considering bus timing.

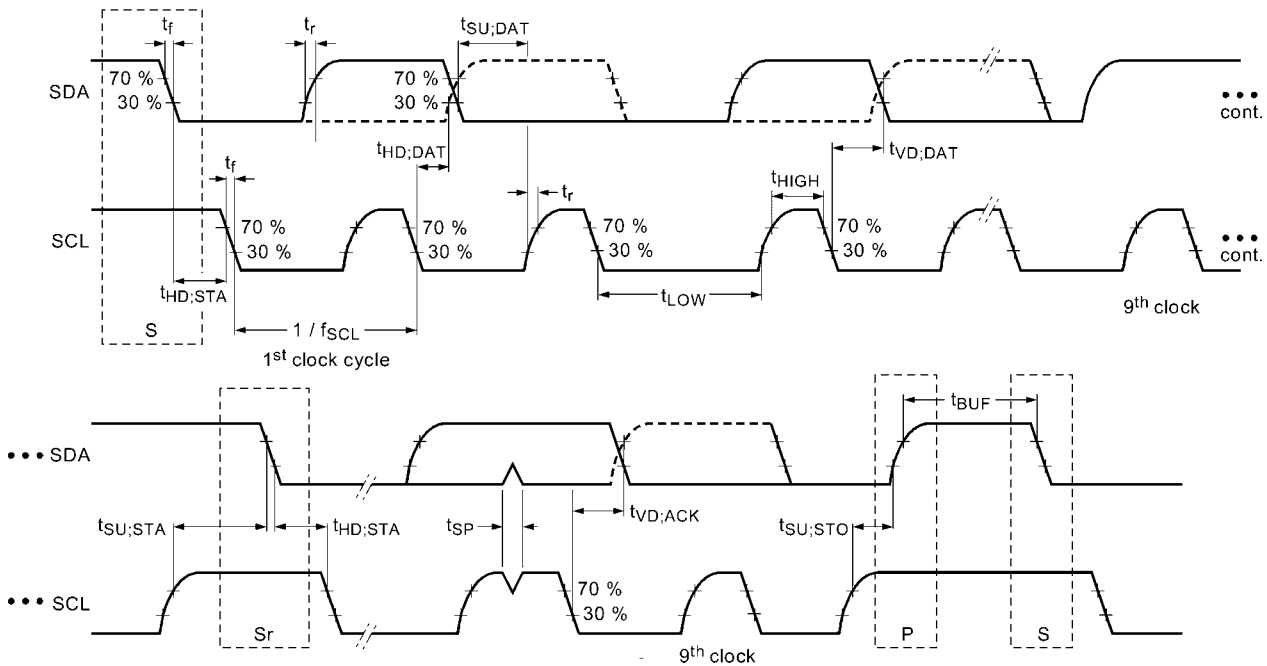

Figure 5. I<sup>2</sup>C Slave Timing Diagram

## 2.5 General I<sup>2</sup>C Information

The SCL and SDA signals are driven by open-drain buffers and a pull-up resistor is required to make the signals rise to the high state. The value of the pull-up resistors depends on the system I<sup>2</sup>C clock rate and the capacitance load on the I<sup>2</sup>C bus.

Higher resistance value pull-up resistors consume less power, but have a slower the rise time (due to the RC time constant between the bus capacitance and the pull-up resistor) and will limit the I<sup>2</sup>C clock frequency.

Lower resistance value pull-up resistors consume more power, but enable higher I<sup>2</sup>C clock operating frequencies.

High bus capacitance is due to long bus lines or a high number of I<sup>2</sup>C devices connected to the bus. A lower value resistance pull-up resistor is required in higher bus capacitance systems.

For standard 100 kHz clock I<sup>2</sup>C, pull-up resistors typically are between 5k and 10 kΩ. For a heavily loaded bus, the pull-up resistor value may need to be reduced. For higher speed 400 kHz or 800 kHz clock I<sup>2</sup>C, bus capacitance will need to be kept low, in addition to selecting a lower value resistance pull-up resistor. Pull-up resistors for high speed buses typically are about 1 KΩ.

In a well designed system with a microprocessor and one I<sup>2</sup>C device on the bus, with good board layout and routing, the I<sup>2</sup>C bus capacitance can be kept under 20 pF. With a 1K pull-up resistor, the I<sup>2</sup>C clock rates can be well in excess of a few megahertz.

## 3 Modes of Operation

Table 7. Modes of Operation Description

Mode	I <sup>2</sup> C Bus State	Function Description
STANDBY	I <sup>2</sup> C communication is possible.	Only POR and digital blocks are enabled. Analog subsystem is disabled.
ACTIVE	I <sup>2</sup> C communication is possible.	All blocks are enabled (POR, Digital, Analog).

## 4 Functionality

MAG3110 is a small low-power, digital output, 3-axis linear magnetometer packaged in a 10 pin DFN. The device contains a magnetic transducer for sensing and an ASIC for control and digital I<sup>2</sup>C communications.

### 4.1 I<sup>2</sup>C Serial Interface

Communication with the MAG3110 takes place over an I<sup>2</sup>C bus. The MAG3110 also has an interrupt signal indicating that new magnetic data readings are available. Interrupt driven sampling allows operation without the overhead of software polling.

### 4.2 Factory Calibration

MAG3110 is factory calibrated for sensitivity, offset and temperature coefficient. All factory calibration coefficients are applied automatically by the MAG3110 ASIC before the magnetic field readings are written to registers 0x01 to 0x06 (see [section 5](#)). There is no need for the user to apply the calibration correction in the software and the calibration coefficients are not therefore accessible to the user.

The offset registers in the addresses 0x09 to 0x0E are not a factory calibration offset but allow the user to define a hard iron offset which can be automatically subtracted from the magnetic field readings (see [section 4.3.3](#)).

### 4.3 Digital Interface

**Table 8. Serial Interface Pin Description**

Pin Name	Pin Description
VDDIO	IO voltage
SCL	I <sup>2</sup> C Serial Clock
SDA	I <sup>2</sup> C Serial Data
INT	Data ready interrupt pin

There are two signals associated with the I<sup>2</sup>C bus: the Serial Clock Line (SCL) and the Serial Data line (SDA). External pull-up resistors (connected to VDDIO) are needed for SDA and SCL. When the bus is free, both lines are high. The I<sup>2</sup>C interface is compliant with Fast mode (400 kHz), and Normal mode (100 kHz) I<sup>2</sup>C standards.

#### 4.3.1 General I<sup>2</sup>C Operation

I<sup>2</sup>C is an asynchronous, open collector driven, addressed and packetized serial bus interface. It is capable of supporting multiple masters and multiple slave devices on the same bus. I<sup>2</sup>C uses two bi-directional lines, the serial clock line or SCL and the serial data line or SDA. Pull-up resistors are required on both lines.

An I<sup>2</sup>C transaction starts with a start condition (START) and ends with a stop condition (STOP). A START condition is defined as a HIGH to LOW transition on the data line while the clock line is held HIGH. A STOP condition is defined as a LOW to HIGH transition on the data line while the clock line is held HIGH. At all other times, the data line can only change state when the clock line is low. If the data line changes state when the clock is high, the I<sup>2</sup>C transaction is aborted and the new start or stop condition is recognized.

After START has been transmitted by the master, the bus is considered busy. The next byte of data transmitted after START condition is the slave address in the first 7 bits, and the eighth bit is the Read/Write (R/W) bit (read = 1, write = 0). The R/W bit determines whether the I<sup>2</sup>C master intends on receiving data from the slave – Read mode or intends to transmit data to the slave – Write mode. When an address is sent, each device on the I<sup>2</sup>C bus compares the first 7 bits after a start condition with its own internal address. If the address matches, the device considers itself addressed by the Master and continues to respond. If the address does not match, the device ignores further bus activity until the next start condition happens.

The ninth bit (clock pulse), following each I<sup>2</sup>C byte is for the acknowledge (ACK) bit. The master releases the SDA line during the ACK period. Because of the pull-up resistor, the data line will tend to float high. To signal ACK back to the master, the slave must then pull the data line low during this clock period.

The number of bytes per transfer can be unlimited. If a receiving device can't accept another complete byte of data until it has performed some other function, it can hold the clock line, SCL, low to force the transmitter into a wait state. Data transfer only continues when the receiver is ready for another byte and releases the data line. This delay action is called clock stretching. The MAG3110 device does clock stretching.

A data transfer is always terminated by a STOP.

The MAG3110 I<sup>2</sup>C 7-bit device address is 0x0E. In I<sup>2</sup>C practice, the device address is shifted left by one bit field and a read/write bit is set in the lowest bit position. The I<sup>2</sup>C 8-bit write address is 0x1C and the read address is 0x1D.

The I<sup>2</sup>C 8-bit write address is 0x3A and the read address is 0x3B. Please consult the factory for alternate addresses.



See Figure 6 for details on how to perform read/write operations with MAG3110.

#### Single/Burst Write Operation

IIC Start	IIC Slave ADDR (R/W bit = 0)	MAG3110 Register Address to Start Write	Data0*	Data1	—	IIC STOP
-----------	---------------------------------	---	--------	-------	---	----------

\* Data Bytes Outgoing

#### Single/Burst Read Operation

IIC Start	IIC Slave ADDR (R/W bit = 0)	MAG3110 Register Address to Start Read	IIC Repeated Start	IIC Slave ADDR (R/W bit = 1)	Data0*	Data1	—	IIC STOP
-----------	---------------------------------	--	--------------------	---------------------------------	--------	-------	---	----------

\* Data Bytes Incoming

Figure 6. MAG3110 I<sup>2</sup>C Generic Read/Write Operations

### 4.3.2 Fast Read Mode

When the Fast Read (FR) bit is set (CTRL\_REG1, 0x10, bit 2), the MSB 8-bit data is read through the I<sup>2</sup>C bus. Auto-increment is set to skip over the LSB data. When FR bit is cleared, the complete 16-bit data is read accessing all 6 bytes sequentially (OUT\_X\_MSB, OUT\_X\_LSB, OUT\_Y\_MSB, OUT\_Y\_LSB, OUT\_Z\_MSB, OUT\_Z\_LSB).

### 4.3.3 User Offset Corrections

The 2's complement user offset correction register values are used to compensate for correcting the X, Y, and Z-axis after device board mount. These values may be used to compensate for hard iron interference.

Depending on the setting of the RAW bit (CTRL\_REG2, 0x11, bit 5) the magnetic field sample data is corrected with the user offset values (RAW = 0), or can be read out uncorrected for user offset values (RAW = 1). The factory calibration correction is always applied irrespective of the setting of the RAW bit.

The factory calibration for gain, offset and temperature compensation is always automatically applied irrespective of the setting of the RAW bit which only controls the subtraction of the user defined hard iron offset.

### 4.3.4 INT1

The DR\_STATUS register (see section 5.1.1) contains the ZYXDR bit which denotes the presence of new measurement data on one or more axes. Software polling can be used to detect the transition of the ZYXDR bit from 0 to 1 but, since the ZYXDR bit is also logically connected to the INT1 pin, a more efficient approach is to use INT1 to trigger a software interrupt when new measurement data is available as follows:

1. Put MAG3110 in ACTIVE mode (CTRL\_REG1 = 0bXXXXXX01).
2. Idle until INT1 goes HIGH and activates an interrupt service routine in the user software.
3. Read magnetometer data as required from registers 0x01 to 0x06. INT1 is cleared when register 0x01 OUT\_X\_MSB is read and this register must therefore always be read in the interrupt service routine.
4. Return to idle in step 2.

### 4.3.5 Triggered Measurements

Set the TM bit in CTRL\_REG1 when you want the part to acquire only 1 sample on each axis. See table below for details.

AC	TM	Description
0	0	ASIC is in low power standby mode.
0	1	The ASIC shall exit standby mode, perform one measurement cycle based on the programmed ODR and OSR setting, update the I <sup>2</sup> C data registers and re-enter standby mode.
1	0	The ASIC shall perform continuous measurements based on the current OSR and ODR settings.
1	1	The ASIC shall continue current measurement at fastest applicable ODR for programmed OSR. The ASIC shall return to programmed ODR after completing the triggered measurement.

## 5 Register Description

Table 9. Register Address Map

Name	Type	Register Address	Auto-Increment Address (Fast Read) <sup>(1)</sup>	Default Value	Comment
DR_STATUS <sup>(2)</sup>	R	0x00	0x01	0000 0000	Data ready status per axis
OUT_X_MSB <sup>(2)</sup>	R	0x01	0x02 (0x03)	data	Bits [15:8] of X measurement
OUT_X_LSB <sup>(2)</sup>	R	0x02	0x03	data	Bits [7:0] of X measurement
OUT_Y_MSB <sup>(2)</sup>	R	0x03	0x04 (0x05)	data	Bits [15:8] of Y measurement
OUT_Y_LSB <sup>(2)</sup>	R	0x04	0x05	data	Bits [7:0] of Y measurement
OUT_Z_MSB <sup>(2)</sup>	R	0x05	0x06 (0x07)	data	Bits [15:8] of Z measurement
OUT_Z_LSB <sup>(2)</sup>	R	0x06	0x07	data	Bits [7:0] of Z measurement
WHO_AM_I <sup>(2)</sup>	R	0x07	0x08	0xC4	Device ID Number
SYSMOD <sup>(2)</sup>	R	0x08	0x09	data	Current System Mode
OFF_X_MSB	R/W	0X09	0x0A	0000 0000	Bits [14:7] of user X offset
OFF_X_LSB	R/W	0X0A	0X0B	0000 0000	Bits [6:0] of user X offset
OFF_Y_MSB	R/W	0X0B	0X0C	0000 0000	Bits [14:7] of user Y offset
OFF_Y_LSB	R/W	0X0C	0X0D	0000 0000	Bits [6:0] of user Y offset
OFF_Z_MSB	R/W	0X0D	0X0E	0000 0000	Bits [14:7] of user Z offset
OFF_Z_LSB	R/W	0X0E	0X0F	0000 0000	Bits [6:0] of user Z offset
DIE_TEMP <sup>(2)</sup>	R	0X0F	0X10	data	Temperature, signed 8 bits in °C
CTRL_REG1 <sup>(3)</sup>	R/W	0X10	0X11	0000 0000	Operation modes
CTRL_REG2 <sup>(3)</sup>	R/W	0X11	0x12	0000 0000	Operation modes

1. Fast Read mode for quickly reading the Most Significant Bytes (MSB) of the sampled data.
2. Register contents are preserved when transitioning from "ACTIVE" to "STANDBY" mode.
3. Modification of this register's contents can only occur when device is "STANDBY" mode, except the TM and AC bit fields in CTRL\_REG1 register.

## 5.1 Sensor Status

### 5.1.1 DR\_STATUS (0x00)

#### Data Ready Status

This read-only status register provides the acquisition status information on a per-sample basis, and reflects real-time updates to the OUT\_X, OUT\_Y, and OUT\_Z registers.

**Table 10. DR\_STATUS Register**

Bit 7	Bit 6	Bit 5	Bit 4	Bit 3	Bit 2	Bit 1	Bit 0
ZYXOW	ZOW	YOW	XOW	ZYXDR	ZDR	YDR	XDR

**Table 11. DR\_STATUS Description**

ZYXOW	X, Y, Z-axis Data Overwrite. Default value: 0. 0: No data overwrite has occurred. 1: Previous X or Y or Z data was overwritten by new X or Y or Z data before it was completely read.
ZOW	Z-axis Data Overwrite. Default value: 0. 0: No data overwrite has occurred. 1: Previous Z-axis data was overwritten by new Z-axis data before it was read.
YOW	Y-axis Data Overwrite. Default value: 0. 0: No data overwrite has occurred. 1: Previous Y-axis data was overwritten by new Y-axis data before it was read.
XOW	X-axis Data Overwrite. Default value: 0. 0: No data overwrite has occurred. 1: Previous X-axis data was overwritten by new X-axis data before it was read.
ZYXDR	X or Y or Z-axis new Data Ready. Default value: 0. 0: No new set of data ready. 1: New set of data is ready.
ZDR	Z-axis new Data Available. Default value: 0. 0: No new Z-axis data is ready. 1: New Z-axis data is ready.
YDR	Z-axis new Data Available. Default value: 0. 0: No new Y-axis data is ready. 1: New Y-axis data is ready.
XDR	Z-axis new Data Available. Default value: 0. 0: No new X-axis data is ready. 1: New X-axis data is ready.

**ZYXOW** is set to 1 whenever new data is acquired before completing the retrieval of the previous set. This event occurs when the content of at least one data register (i.e. OUT\_X, OUT\_Y, OUT\_Z) has been overwritten. ZYXOW is cleared when the high-bytes of the data (OUT\_X\_MSB, OUT\_Y\_MSB, OUT\_Z\_MSB) of all active channels are read.

**ZOW** is set to 1 whenever new Z-axis acquisition is completed before the retrieval of the previous data. When this occurs the previous data is overwritten. ZOW is cleared any time OUT\_Z\_MSB register is read.

**YOW** is set to 1 whenever new Y-axis acquisition is completed before the retrieval of the previous data. When this occurs the previous data is overwritten. YOW is cleared any time OUT\_Y\_MSB register is read.

**XOW** is set to 1 whenever new X-axis acquisition is completed before the retrieval of the previous data. When this occurs the previous data is overwritten. XOW is cleared any time OUT\_X\_MSB register is read.

**ZYXDR** signals that new acquisition for any of the enabled channels is available. ZYXDR is cleared when the high-bytes of the data (OUT\_X\_MSB, OUT\_Y\_MSB, OUT\_Z\_MSB) of all the enabled channels are read.

**ZDR** is set to 1 whenever new Z-axis data acquisition is completed. ZDR is cleared any time OUT\_Z\_MSB register is read.

**YDR** is set to 1 whenever new Y-axis data acquisition is completed. YDR is cleared any time OUT\_Y\_MSB register is read.

**XDR** is set to 1 whenever new X-axis data acquisition is completed. XDR is cleared any time OUT\_X\_MSB register is read.

## 5.1.2 OUT\_X\_MSB (0x01), OUT\_X\_LSB (0x02), OUT\_Y\_MSB (0x03), OUT\_Y\_LSB (0x04), OUT\_Z\_MSB (0x05), OUT\_Z\_LSB (0x06)

X-axis, Y-axis, and Z-axis 16-bit output sample data of the magnetic field strength expressed as signed 2's complement numbers.

When RAW mode is enabled (RAW = 1), the output range is between -15,000 to 15,000 bit counts (the combination of the 1000  $\mu$ T full scale range and the zero flux offset ranging up to 500  $\mu$ T).

When RAW mode is not enabled (RAW = 0), the output range is between -30,000 to 30,000 bit counts when the user offset ranging between -15,000 to 15,000 bit counts is included

The DR\_STATUS register, OUT\_X\_MSB, OUT\_X\_LSB, OUT\_Y\_MSB, OUT\_Y\_LSB, OUT\_Z\_MSB, and OUT\_Z\_LSB are stored in the auto-incrementing address range of 0x00 to 0x06. Data acquisition is a sequential read of 6 bytes.

If the Fast Read (FR) bit is set in CTRL\_REG1 (0x10), auto-increment will skip over LSB of the X, Y, Z sample registers. This will shorten the data acquisition from 6 bytes to 3 bytes. If the LSB registers are directly addressed, the LSB information can still be read regardless of FR bit setting.

The preferred method for reading data registers is the burst read method where the user application acquires data sequentially starting from register 0x01. If register 0x01 is not read, the rest of the data registers (0x02 - 0x06) will not be updated with the most recent acquisition. It is still possible to address individual data registers, however register 0x01 must be read prior to ensure reading latest acquisition.

**Table 12. OUT\_X\_MSB Register**

Bit 7	Bit 6	Bit 5	Bit 4	Bit 3	Bit 2	Bit 1	Bit 0
XD15	XD14	XD13	XD12	XD11	XD10	XD9	XD8

**Table 13. OUT\_X\_LSB Register**

Bit 7	Bit 6	Bit 5	Bit 4	Bit 3	Bit 2	Bit 1	Bit 0
XD7	XD6	XD5	XD4	XD3	XD2	XD1	XD0

**Table 14. OUT\_Y\_MSB Register**

Bit 7	Bit 6	Bit 5	Bit 4	Bit 3	Bit 2	Bit 1	Bit 0
YD15	YD14	YD13	YD12	YD11	YD10	YD9	YD8

**Table 15. OUT\_Y\_LSB Register**

Bit 7	Bit 6	Bit 5	Bit 4	Bit 3	Bit 2	Bit 1	Bit 0
YD7	YD6	YD5	YD4	YD3	YD2	YD1	YD0

**Table 16. OUT\_Z\_MSB Register**

Bit 7	Bit 6	Bit 5	Bit 4	Bit 3	Bit 2	Bit 1	Bit 0
ZD15	ZD14	ZD13	ZD12	ZD11	ZD10	ZD9	ZD8

**Table 17. OUT\_Z\_LSB Register**

Bit 7	Bit 6	Bit 5	Bit 4	Bit 3	Bit 2	Bit 1	Bit 0
ZD6	ZD6	ZD5	ZD4	ZD3	ZD2	ZD1	ZD0

## 5.2 Device ID

### 5.2.1 WHO\_AM\_I (0x07)

Device identification register. This read-only register contains the device identifier which is set to 0xC4. This value is factory programmed. Consult factory for custom alternate values.

Table 18. WHO\_AM\_I Register

Bit 7	Bit 6	Bit 5	Bit 4	Bit 3	Bit 2	Bit 1	Bit 0
1	1	0	0	0	1	0	0

### 5.2.2 SYSMOD (0x08)

The read-only system mode register indicates the current device operating mode.

Table 19. SYSMOD Register

Bit 7	Bit 6	Bit 5	Bit 4	Bit 3	Bit 2	Bit 1	Bit 0
0	0	0	0	0	0	SYSMOD1	SYSMOD0

Table 20. SYSMOD Description

SYSMOD	System Mode. Default value: 00. 00: STANDBY mode. 01: ACTIVE mode, RAW data. 10: ACTIVE mode, non-RAW user-corrected data.
--------	---

## 5.3 User Offset Correction

### 5.3.1 OFF\_X\_MSB (0x09), OFF\_X\_LSB (0x0A), OFF\_Y\_MSB (0x0B), OFF\_Y\_LSB (0x0C), OFF\_Z\_MSB (0x0D), OFF\_Z\_LSB (0x0E)

X-axis, Y-axis, and Z-axis user defined offsets in 2's complement format which are used when RAW = 0 (see [section 5.5.2](#)) to correct for the MAG3110 zero flux offset and for hard iron offsets on the PCB caused by external components. The maximum sensible range for the user offsets is in the range -15,000 to 15,000 bit counts comprising the sum of the correction for the zero flux offset (range -500  $\mu$ T to 500  $\mu$ T or -5000 to 5000 bit counts) and the PCB hard iron offset (range -1000  $\mu$ T to 1000  $\mu$ T or -10,000 to 10,000 bit counts).

The user offsets are automatically subtracted by the MAG3110 logic when RAW = 0 before the magnetic field readings are written to the data measurement registers 0x01 to 0x06. The maximum range of the X, Y and Z data measurement registers when RAW = 0 is therefore -30,000 to 30,000 bit counts and is computed without clipping. The user offsets are not subtracted when RAW = 1. The least significant bit of the user defined X, Y and Z offsets is forced to be zero irrespective of the value written by the user.

If the MAG3110 zero flux offset and PCB hard iron offset corrections are performed by an external microprocessor (the most likely scenario) then the user offset registers can be ignored and the RAW bit should be set to 1.

The user offset registers should not be confused with the factory calibration corrections which are not user accessible and which are always applied to the measured magnetic data.

Table 21. OFF\_X\_MSB Register

Bit 7	Bit 6	Bit 5	Bit 4	Bit 3	Bit 2	Bit 1	Bit 0
XD14	XD13	XD12	XD11	XD10	XD9	XD8	XD7

Table 22. OFF\_X\_LSB Register

Bit 7	Bit 6	Bit 5	Bit 4	Bit 3	Bit 2	Bit 1	Bit 0
XD6	XD5	XD4	XD3	XD2	XD1	XD0	0

Table 23. OFF\_Y\_MSB Register

Bit 7	Bit 6	Bit 5	Bit 4	Bit 3	Bit 2	Bit 1	Bit 0
YD14	YD13	YD12	YD11	YD10	YD9	YD8	YD7

Table 24. OFF\_Y\_LSB Register

Bit 7	Bit 6	Bit 5	Bit 4	Bit 3	Bit 2	Bit 1	Bit 0
YD6	YD5	YD4	YD3	YD2	YD1	YD0	0

**Table 25. OFF\_Z\_MSB Register**

Bit 7	Bit 6	Bit 5	Bit 4	Bit 3	Bit 2	Bit 1	Bit 0
ZD14	ZD13	ZD12	ZD11	ZD10	ZD9	ZD8	ZD7

**Table 26. OFF\_Z\_LSB Register**

Bit 7	Bit 6	Bit 5	Bit 4	Bit 3	Bit 2	Bit 1	Bit 0
ZD6	ZD5	ZD4	ZD3	ZD2	ZD1	ZD0	0

## 5.4 Temperature

### 5.4.1 DIE\_TEMP (0x0F)

Temperature °C expressed as an 8-bit 2's complement number. The data allows for temperatures from -128°C to 127°C but in actual function the range is from -40°C to 125°C.

**Table 27. TEMP Register**

Bit 7	Bit 6	Bit 5	Bit 4	Bit 3	Bit 2	Bit 1	Bit 0
T7	T6	T5	T4	T3	T2	T1	T0

## 5.5 Control Registers

**Note:** Except for STANDBY mode selection, the device must be in STANDBY mode to change any of the fields within CTRL\_REG1 (0x10).

### 5.5.1 CTRL\_REG1 (0x10)

**Table 28. CTRL\_REG1 Register**

Bit 7	Bit 6	Bit 5	Bit 4	Bit 3	Bit 2	Bit 1	Bit 0
DR2	DR1	DR0	OS1	OS0	FR	TM	AC

**Table 29. CTRL\_REG1 Description**

DR[2:0]	Data rate selection. Default value: 000. See <a href="#">Table 30</a> for more information.
OS [1:0]	This register configures the over sampling ratio or measurement integration time. Default value: 00. See <a href="#">Table 30</a> for more information.
FR	Fast Read selection. Default value: 0. 0: The full 16-bit values are read. 1: Fast Read, 8-bit values read from the MSB registers.
TM	Trigger immediate measurement. Default value: 0 0: Normal operation based on AC condition. 1: Trigger measurement. If part is in ACTIVE mode, any measurement in progress will complete before triggered measurement. In STANDBY mode triggered measurement will occur immediately and part will return to STANDBY mode as soon as the measurement is complete.
AC	Operating mode selection. Default value: 0. 0: STANDBY mode. 1: ACTIVE mode. ACTIVE mode will make periodic measurements based on values programmed in the Data Rate (DR) and Over Sampling Ratio bits (OS).

**Table 30. Over Sampling Ratio and Data Rate Description**

DR2	DR1	DR0	OS1	OS0	Output Rate (Hz)	Over Sample Ratio	Current Est $\mu$ A	Noise Est $\mu$ T rms
0	0	0	0	0	80.00	1	900.0	0.14
0	0	0	0	1	40.00	2	900.0	0.1
0	0	0	1	0	20.00	4	900.0	0.07
0	0	0	1	1	10.00	8	900.0	0.05
0	0	1	0	0	40.00	1	480.0	0.14
0	0	1	0	1	20.00	2	480.0	0.1
0	0	1	1	0	10.00	4	480.0	0.07
0	0	1	1	1	5.00	8	480.0	0.05
0	1	0	0	0	20.00	1	275.0	0.14
0	1	0	0	1	10.00	2	275.0	0.1
0	1	0	1	0	5.00	4	275.0	0.07
0	1	0	1	1	2.50	8	275.0	0.05
0	1	1	0	0	10.00	1	137.5	0.14
0	1	1	0	1	5.00	2	137.5	0.1
0	1	1	1	0	2.50	4	137.5	0.07
0	1	1	1	1	1.25	8	137.5	0.05
1	0	0	0	0	5.00	1	68.8	0.14
1	0	0	0	1	2.50	2	68.8	0.1
1	0	0	1	0	1.25	4	68.8	0.07
1	0	0	1	1	0.63	8	68.8	0.05
1	0	1	0	0	2.50	1	34.4	0.14
1	0	1	0	1	1.25	2	34.4	0.1
1	0	1	1	0	0.63	4	34.4	0.07
1	0	1	1	1	0.31	8	34.4	0.05
1	1	0	0	0	1.25	1	17.2	0.14
1	1	0	0	1	0.63	2	17.2	0.1

**Table 30. Over Sampling Ratio and Data Rate Description**

1	1	0	1	0	0.31	4	17.2	0.07
1	1	0	1	1	0.16	8	17.2	0.05
1	1	1	0	0	0.63	1	8.6	0.14
1	1	1	0	1	0.31	2	8.6	0.1
1	1	1	1	0	0.16	4	8.6	0.07
1	1	1	1	1	0.08	8	8.6	0.05

### 5.5.2 CTRL\_REG2 (0x11)

**Table 31. CTRL\_REG2 Register**

Bit 7	Bit 6	Bit 5	Bit 4	Bit 3	Bit 2	Bit 1	Bit 0
AUTO_MRST_EN	—	RAW	Mag_RST	—	ST_Z	ST_Y	ST_X

**Table 32. CTRL\_REG2 Description**

AUTO_MRST_EN	Automatic Magnetic Sensor Reset. Default value: 0. 0: Automatic magnetic sensor resets off. 1: Automatic magnetic sensor resets on. Similar to Mag_RST, however, the resets occur before each data acquisition.
RAW	Data output correction. Default value: 0. 0: Normal mode: data values are corrected by the user offset register values. 1: Raw mode: data values are not corrected by the user offset register values. The factory calibration is always applied to the measured data stored in registers 0x01 to 0x06 irrespective of the setting of the RAW bit.
Mag_RST	Magnetic Sensor Reset. Default value: 0. 0: Reset cycle not active. 1: Reset cycle initiate or Reset cycle busy/active. When asserted, initiates a magnetic sensor reset cycle that will restore correct operation after exposure to an excessive magnetic field which exceeds the Full Scale Range (see Table 2) but is less than the Maximum Applied Magnetic Field (see Table 3). When the cycle is finished, value returns to 0.
ST_Z	Self-test Z-axis Default value: 0. 0: No Self-test. 1: Self-test, active Z-axis. When this bit is asserted, a magnetic field is generated on the MAG3110 Z-axis to test the operation of this axis. The size of the resulting change is defined as Self-test Output Change in Table 2. The ST_Z bit should be de-asserted at the end of the self-test.
ST_Y	Self-test Y-axis. Default value: 0. 0: No Self-test. 1: Self-test, active Y-axis. When this bit is asserted, a magnetic field is generated on the MAG3110 Y-axis to test the operation of this axis. The size of the resulting change is defined as Self-test Output Change in Table 2. The ST_Y bit should be de-asserted at the end of the self-test.
ST_X	Self-test X-axis. Default value: 0. 0: No Self-test. 1: Self-test, active X-axis. When this bit is asserted, a magnetic field is generated on the MAG3110 X-axis to test the operation of this axis. The size of the resulting change is defined as Self-test Output Change in Table 2. The ST_X bit should be de-asserted at the end of the self-test.



## 6 Geomagnetic Field Maps

The magnitude of the geomagnetic field varies from 25  $\mu\text{T}$  in South America to about 60  $\mu\text{T}$  over Northern China. The horizontal component of the field varies from zero at the magnetic poles to 40  $\mu\text{T}$ .

These web sites have further information:

<http://wdc.kugi.kyoto-u.ac.jp/igrf/>

<http://geomag.usgs.gov>

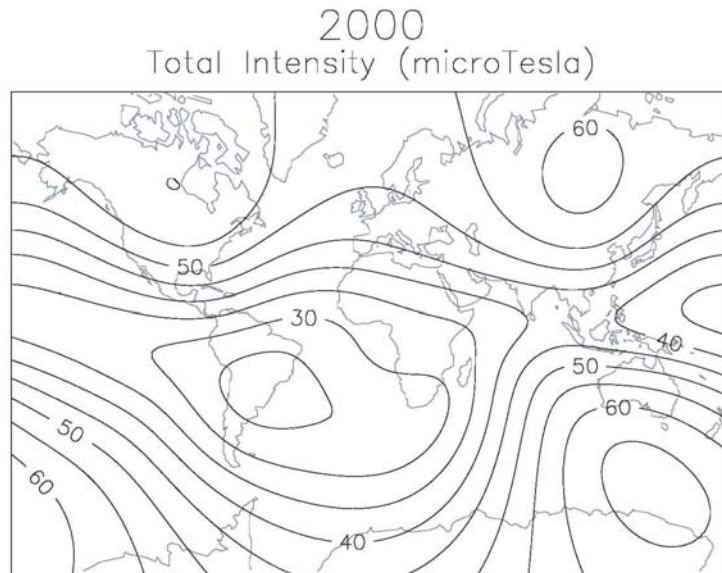

International Geomagnetic Reference Field (IGRF)

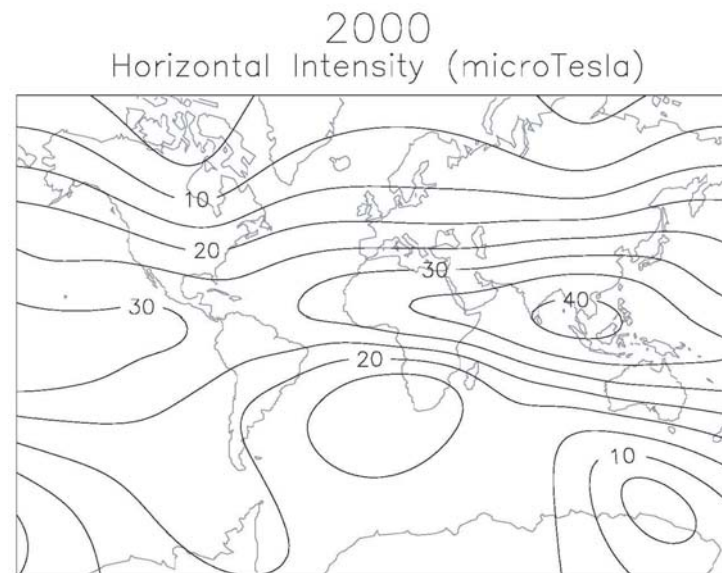

International Geomagnetic Reference Field (IGRF)

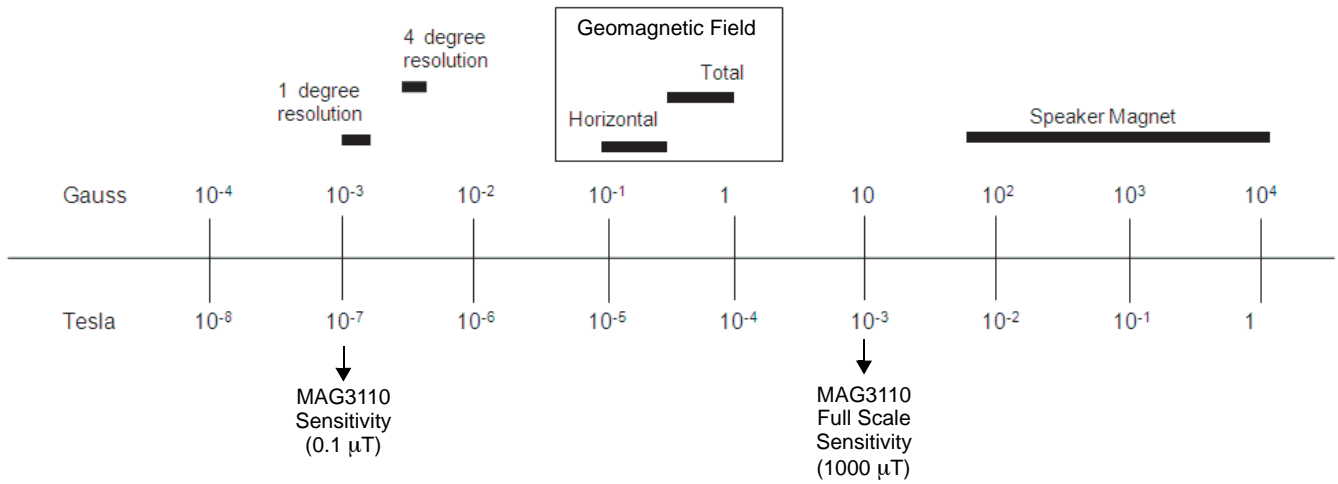

The placement of MAG3110 on the application PCB should be done based on the guidelines given in AN4247, "PCB Layout Guidelines and Recommendations" to minimize magnetic interference to the MAG3110 from other components and ensure that the MAG3110 output does not saturate in fields above  $1000 \mu\text{T}$ .

## 7 Suggested PCB Footprint

Please see Freescale application note AN1902 for additional information on guidelines for QFN and DFN printed circuit board design and assembly.

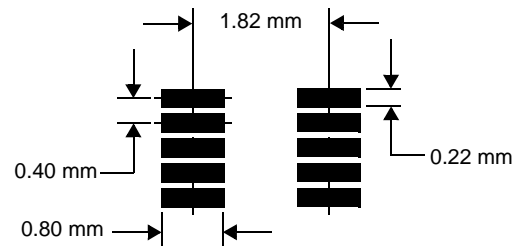

Footprint Complies with IPC-7351A  
Footprint Tolerance: 0.02 mm  
Solder Paste Stencil: 4 mil thickness, type 3 paste is recommended.

**Figure 7. PCB Footprint Dimensions**

# PACKAGE DIMENSIONS

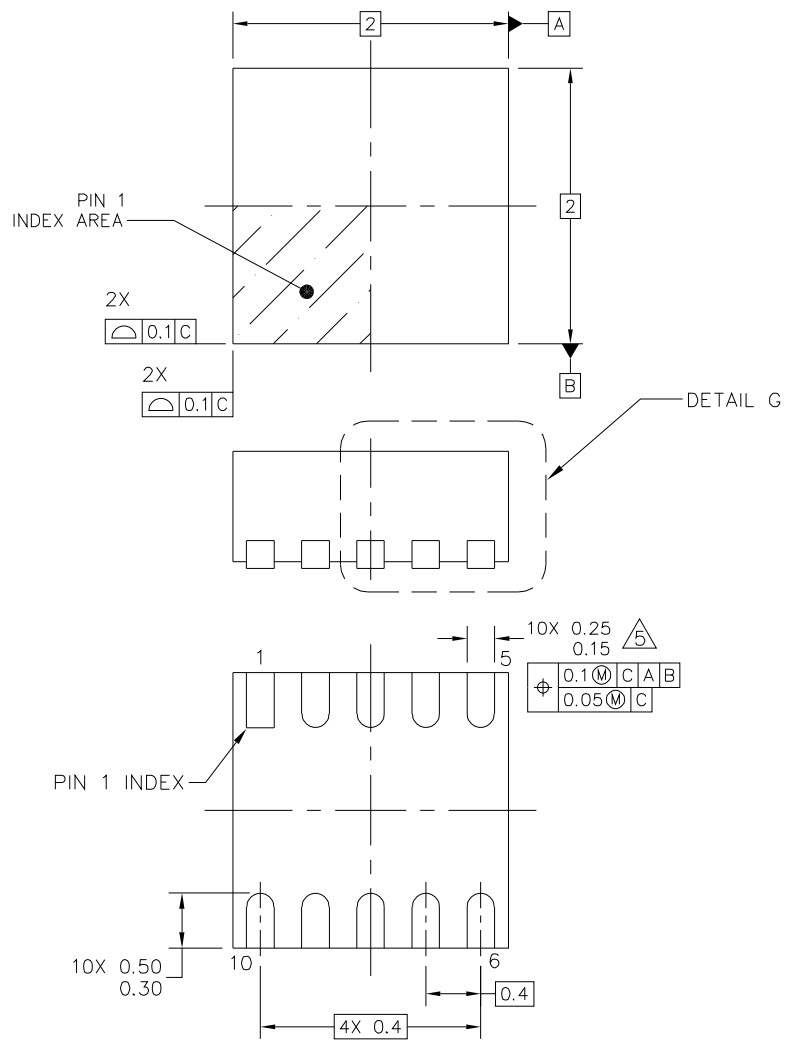

© FREESCALE SEMICONDUCTOR, INC. ALL RIGHTS RESERVED.	MECHANICAL OUTLINE	PRINT VERSION NOT TO SCALE	
TITLE: THERMALLY ENHANCED DUAL FLAT NON-LEADED PACKAGE (COL) 10 TERMINAL, 0.4 PITCH (2 X 2 X 0.85)	DOCUMENT NO: 98ASA00264D	REV: X0	
	CASE NUMBER: 2154-01	01 SEP 2010	
	STANDARD: NON-JEDEC		

**CASE 2154-01  
ISSUE X0  
10 PIN DFN**

## PACKAGE DIMENSIONS

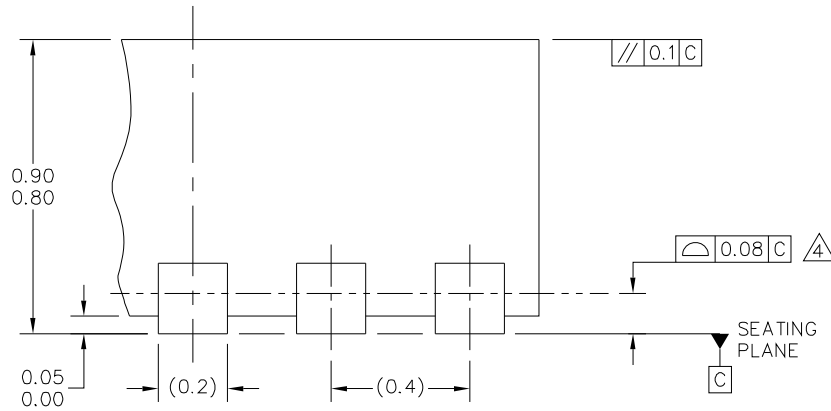



DETAIL G

© FREESCALE SEMICONDUCTOR, INC. ALL RIGHTS RESERVED.	MECHANICAL OUTLINE	PRINT VERSION NOT TO SCALE	
TITLE: THERMALLY ENHANCED DUAL FLAT NON-LEADED PACKAGE (COL) 10 TERMINAL, 0.4 PITCH (2 X 2 X 0.85)	DOCUMENT NO: 98ASA00264D	REV: X0	
	CASE NUMBER: 2154-01	01 SEP 2010	
	STANDARD: NON-JEDEC		

**CASE 2154-01  
ISSUE X0  
10 PIN DFN**

## PACKAGE DIMENSIONS

NOTES:

1. ALL DIMENSIONS ARE IN MILLIMETERS.
2. DIMENSIONING AND TOLERANCING PER ASME Y14.5M-1994.
3. THIS IS NON JEDEC REGISTERED PACKAGE.
4.  COPLANARITY APPLIES TO THE TERMINALS AND ALL OTHER BOTTOM SURFACE METALLIZATION.
5.  THIS DIMENSION APPLIES TO METALLIZED TERMINAL AND IS MEASURE BETWEEN 0.15 AND 0.25 FROM THE TERMINAL TIP. IF THE TERMINAL HAS THE OPTIONAL RADIUS ON THE OTHER END OF THE TERMINAL, THIS DIMENSION SHALL NOT BE MEASURED IN THE RADIUS AREA.

© FREESCALE SEMICONDUCTOR, INC. ALL RIGHTS RESERVED.	MECHANICAL OUTLINE	PRINT VERSION NOT TO SCALE	
TITLE: THERMALLY ENHANCED DUAL FLAT NON-LEADED PACKAGE (COL) 10 TERMINAL, 0.4 PITCH (2 X 2 X 0.85)	DOCUMENT NO: 98ASA00264D	REV: X0	
	CASE NUMBER: 2154-01	01 SEP 2010	
	STANDARD: NON-JEDEC		

**CASE 2154-01  
ISSUE X0  
10 PIN DFN**

**MAG3110**

## **How to Reach Us:**

### **Home Page:**

[www.freescale.com](http://www.freescale.com)

### **Web Support:**

<http://www.freescale.com/support>

### **USA/Europe or Locations Not Listed:**

Freescale Semiconductor, Inc.  
Technical Information Center, EL516  
2100 East Elliot Road  
Tempe, Arizona 85284  
1-800-521-6274 or +1-480-768-2130  
[www.freescale.com/support](http://www.freescale.com/support)

### **Europe, Middle East, and Africa:**

Freescale Halbleiter Deutschland GmbH  
Technical Information Center  
Schatzbogen 7  
81829 Muenchen, Germany  
+44 1296 380 456 (English)  
+46 8 52200080 (English)  
+49 89 92103 559 (German)  
+33 1 69 35 48 48 (French)  
[www.freescale.com/support](http://www.freescale.com/support)

### **Japan:**

Freescale Semiconductor Japan Ltd.  
Headquarters  
ARCO Tower 15F  
1-8-1, Shimo-Meguro, Meguro-ku,  
Tokyo 153-0064  
Japan  
0120 191014 or +81 3 5437 9125  
[support.japan@freescale.com](mailto:support.japan@freescale.com)

### **Asia/Pacific:**

Freescale Semiconductor China Ltd.  
Exchange Building 23F  
No. 118 Jianguo Road  
Chaoyang District  
Beijing 100022  
China  
+86 010 5879 8000  
[support.asia@freescale.com](mailto:support.asia@freescale.com)

### **For Literature Requests Only:**

Freescale Semiconductor Literature Distribution Center  
1-800-441-2447 or +1-303-675-2140  
Fax: +1-303-675-2150  
[LDCForFreescaleSemiconductor@hibbertgroup.com](mailto:LDCForFreescaleSemiconductor@hibbertgroup.com)

Information in this document is provided solely to enable system and software implementers to use Freescale Semiconductor products. There are no express or implied copyright licenses granted hereunder to design or fabricate any integrated circuits or integrated circuits based on the information in this document.

Freescale Semiconductor reserves the right to make changes without further notice to any products herein. Freescale Semiconductor makes no warranty, representation or guarantee regarding the suitability of its products for any particular purpose, nor does Freescale Semiconductor assume any liability arising out of the application or use of any product or circuit, and specifically disclaims any and all liability, including without limitation consequential or incidental damages. "Typical" parameters that may be provided in Freescale Semiconductor data sheets and/or specifications can and do vary in different applications and actual performance may vary over time. All operating parameters, including "Typicals", must be validated for each customer application by customer's technical experts. Freescale Semiconductor does not convey any license under its patent rights nor the rights of others. Freescale Semiconductor products are not designed, intended, or authorized for use as components in systems intended for surgical implant into the body, or other applications intended to support or sustain life, or for any other application in which the failure of the Freescale Semiconductor product could create a situation where personal injury or death may occur. Should Buyer purchase or use Freescale Semiconductor products for any such unintended or unauthorized application, Buyer shall indemnify and hold Freescale Semiconductor and its officers, employees, subsidiaries, affiliates, and distributors harmless against all claims, costs, damages, and expenses, and reasonable attorney fees arising out of, directly or indirectly, any claim of personal injury or death associated with such unintended or unauthorized use, even if such claim alleges that Freescale Semiconductor was negligent regarding the design or manufacture of the part.

Freescale and the Freescale logo are trademarks of Freescale Semiconductor, Inc., Reg. U.S. Pat. & Tm. Off. Xtrinsic is a trademark of Freescale Semiconductor, Inc. All other product or service names are the property of their respective owners.

© Freescale Semiconductor, Inc. 2011. All rights reserved.

RoHS-compliant and/or Pb-free versions of Freescale products have the functionality and electrical characteristics of their non-RoHS-compliant and/or non-Pb-free counterparts. For further information, see <http://www.freescale.com> or contact your Freescale sales representative.

For information on Freescale's Environmental Products program, go to <http://www.freescale.com/epp>.