

STRUCTURE	Silicon Monolithic Integrated Circuit
TYPE	Regulator IC for Memory Termination
PRODUCT SERIES	BD3538FVM
FUNCTION	<ul style="list-style-type: none"> • Built-in Push-pull Amplifier for Termination (VTT) • Built-in Reference Voltage Circuit (VREF) • Dual Channel (DDR- II)

○ABSOLUTE MAXIMUM RATINGS (Ta=25°C)

Parameter	Symbol	Limit	Unit
Input Voltage	VCC	7 ^{*1*2}	V
Enable Input Voltage	VEN	7 ^{*1*2}	V
Termination Input Voltage	VTT_IN	7 ^{*1*2}	V
VDDQ Reference Voltage	VDDQ	7 ^{*1*2}	V
Output Current	ITT	1	A
Power Dissipation	Pd	437.5 ^{*3}	mW
Operating Temperature Range	Topr	-40~+105	°C
Storage Temperature Range	Tstg	-55~+150	°C
Maximum Junction Temperature	Tjmax	+150	°C

*1 Should not exceed Pd.

*2 Instantaneous surge voltage, back electromotive force and voltage under less than 10% duty cycle.

*3 Reduced by 3.5mW for each increase in Ta of 1°C over 25°C (With no heat sink) .

○OPERATING CONDITIONS (Ta=25°C)

Parameter	Symbol	MIN	MAX	Unit
Input Voltage	VCC	2.7	5.5	V
Termination Input Voltage	VTT_IN	1.0	5.5	V
VDDQ Reference Voltage	VDDQ	1.0	2.75	V
Enable Input Voltage	VEN	-0.3	5.5	V

★ This product is designed for protection against radioactive rays.

Status of this document

The Japanese version of this document is the official specification.

This translated version is intended only as a reference, to aid in understanding the official version.

If there are any differences between the original and translated versions of this document, the official Japanese language version takes priority.

○ELECTRICAL CHARACTERISTICS (unless otherwise noted, Ta=25°C, VCC=3.3V, VEN=3V, VDDQ=1.8V, VTT_IN=1.8V)

Parameter	Symbol	Standard Value			Unit	Condition
		MIN	TYP	MAX		
Standby Current	IST	-	0.5	1.0	mA	VEN=0V
Bias Current	ICC	-	2	4	mA	VEN=3V
[Enable]						
High Level Enable Input Voltage	VENHIGH	2.3	-	5.5	V	
Low Level Enable Input Voltage	VENLOW	-0.3	-	0.8	V	
Enable Pin Input Current	IEN	-	7	10	uA	VEN=3V
[Termination]						
Termination Output Voltage 1	VTT1	VREF-30m	VREF	VREF+30m	V	ITT=-1.0A to 1.0A Ta=0°C to 105°C
Termination Output Voltage 2	VTT2	VREF-30m	VREF	VREF+30m	V	VCC=5V, VDDQ=2.5V VTT_IN=2.5V ITT=-1.0A to 1.0A Ta=0°C to 105°C
Source Current	ITT+	1.0	-	-	A	
Sink Current	ITT-	-	-	-1.0	A	
Load Regulation	ΔVTT	-	-	50	mV	ITT=-1.0A to 1.0A
Line Regulation	Reg.I	-	20	40	mV	
Upper Side ON Resistance 1	HRON1	-	0.45	0.9	Ω	
Lower Side ON Resistance 1	LRON1	-	0.45	0.9	Ω	
Upper Side ON Resistance 2	HRON2	-	0.4	0.8	Ω	Vcc=5V, VDDQ=2.5V VTT_IN=2.5V
Lower Side ON Resistance 2	LRON2	-	0.4	0.8	Ω	Vcc=5V, VDDQ=2.5V VTT_IN=2.5V
[Input of Reference Voltage]						
Input Impedance	ZVDDQ	70	100	130	kΩ	
Output Voltage 1	VREF1	1/2×VDDQ -18m	1/2×VDDQ	1/2×VDDQ +18m	V	IREF=-5mA to 5mA Ta=0°C to 105°C
Output Voltage 2	VREF2	1/2×VDDQ -40m	1/2×VDDQ	1/2×VDDQ +40m	V	IREF=-10mA to 10mA Ta=0°C to 105°C
Output Voltage 3	VREF3	1/2×VDDQ -25m	1/2×VDDQ	1/2×VDDQ +25m	V	VCC=5V, VDDQ=2.5V VTT_IN=2.5V IREF=-5mA to 5mA Ta=0°C to 105°C
Output Voltage 4	VREF4	1/2×VDDQ -40m	1/2×VDDQ	1/2×VDDQ +40m	V	VCC=5V, VDDQ=2.5V VTT_IN=2.5V IREF=-10mA to 10mA Ta=0°C to 105°C
[UVLO]						
UVLO OFF Voltage	VUVLO	2.40	2.55	2.70	V	VCC : sweep up
Hysteresis Voltage	ΔVUVLO	100	160	220	mV	VCC : sweep down

○PHYSICAL DIMENSION

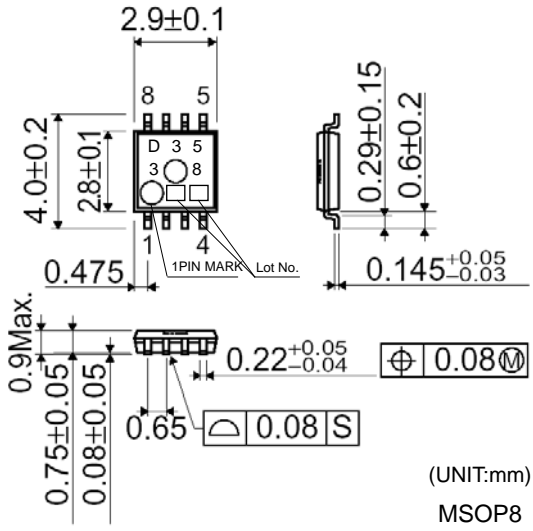

○BLOCK DIAGRAM

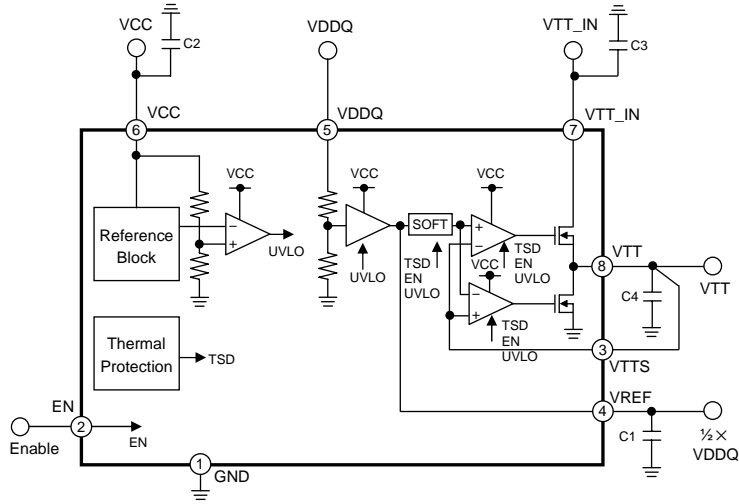

○Pin number Pin name

Pin number	Pin name
1	GND
2	EN
3	VTTS
4	VREF
5	VDDQ
6	VCC
7	VTT_IN
8	VTT

○NOTES FOR USE

- (1) Absolute maximum range
Although the quality of this product is rigorously controlled, and circuit operation is guaranteed within the operation ambient temperature range, the device may be destroyed when applied voltage or operating temperature exceeds its absolute maximum rating. Because the failure mode (such as short mode or open mode) cannot be identified in this instance, it is important to take physical safety measures such as fusing if a specific mode in excess of absolute rating limits is considered for implementation.
- (2) Ground potential
Make sure the potential for the GND pin is always kept lower than the potentials of all other pins, regardless of the operating mode, including transient conditions.
- (3) Thermal Design
Provide sufficient margin in the thermal design to account for the allowable power dissipation (Pd) expected in actual use.
- (4) Using in the strong electromagnetic field
Use in strong electromagnetic fields may cause malfunctions.
- (5) ASO
Be sure that the output transistor for this IC does not exceed the absolute maximum ratings or ASO value.
- (6) Thermal shutdown circuit
The IC is provided with a built-in thermal shutdown (TSD) circuit. When chip temperature reaches the threshold temperature shown below, output goes to a cut-off (open) state. Note that the TSD circuit is designed exclusively to shut down the IC in abnormal thermal conditions. It is not intended to protect the IC per se or guarantee performance when extreme heat occurs. Therefore, the TSD circuit should not be employed with the expectation of continued use or subsequent operation once TSD is operated.

TSD ON temperature [°C] (typ.)	Hysteresis temperature [°C] (typ.)
175	15

- (7) GND pattern
When both a small-signal GND and high current GND are present, single-point grounding (at the set standard point) is recommended, in order to separate the small-signal and high current patterns, and to be sure the voltage change stemming from the wiring resistance and high current does not cause any voltage change in the small-signal GND. In the same way, care must be taken to avoid wiring pattern fluctuations in any connected external component GND.
- (8) Output Capacitor (C1)
Mount an output capacitor between VREF and GND for stability purposes. The VREF output capacitor is for the open loop gain phase compensation. If the capacitor value is not large enough, the output voltage may oscillate. A ceramic 1.0 - 10uF capacitor with minimal susceptibility to temperature is recommended. However, this stability depends on the characteristics of temperature and load. Please confirm operation across a variety of temperature and load conditions.
- (9) Output Capacitor (C4)
Mount an output capacitor between VTT and GND for stability purposes. The output capacitor is for the open loop gain phase compensation and reduces the output voltage load regulation. If the capacitor value is not large enough, the output voltage may oscillate. And if the equivalent series resistance (ESR) is too large, the output voltage rise/drop increases during a sudden load change. A 47 - 220uF polymer capacitor is recommended. However, the stability depends on the characteristics of temperature and load conditions. And if a small ESR capacitor such as a ceramic capacitor is utilized, the output voltage may oscillate due to lack of phase margin. In this case, measures can be taken by adding a resistor in series with this capacitor. Please confirm operation across a variety of temperature and load conditions.
- (10) Input Capacitor (C2, C3)
The input capacitor reduces the output impedance of the voltage supply source connected in the VCC and VTT_IN. If the output impedance of this power supply increases, the input voltage (VCC, VTT_IN) may become unstable. This may result in the output voltage oscillation or lowering ripple rejection. A low ESR 1uF capacitor in VCC and 10uF capacitor in VTT_IN with minimal susceptibility to temperature are preferable, but stability depends on power supply characteristics and the substrate wiring pattern (a parasitic capacitance and impedance). Please confirm operation across a variety of temperature and load conditions.
- (11) Input (VCC, VDDQ, VTT_IN, EN)
The VCC, VDDQ, VTT_IN, and EN are isolated. The UVLO function is integrated to protect faulty operation due to low voltage levels of VCC. VTT output voltage starts up when VCC reaches the UVLO threshold level and EN reaches the threshold level respectively regardless of the start up order in those inputs. And also VREF output voltage starts up when VCC reaches the UVLO threshold level. When the VDDQ and VTT_IN has the same voltage and are supposed to connect each other, VDDQ pin voltage may change due to the voltage drop on the VTT_IN and VDDQ common wiring caused by VTT_IN input current change. This may result in the voltage change of the VTT output. Avoid drawing wiring pattern of VDDQ and VTT_IN so that they do not have common wiring. If the common wiring is inevitable due to limited PCB area, it is recommended that CR filter be added between VTT_IN and VDDQ.
- (12) VTTS
VTTS is to improve load regulation of VTT output. For precise load regulation, VTTS is connected close by VTT to avoid common impedance.
- (13) Please add a protection diode when a large inductance component is connected to the output terminal, and reverse-polarity power is possible at startup or in output OFF condition.

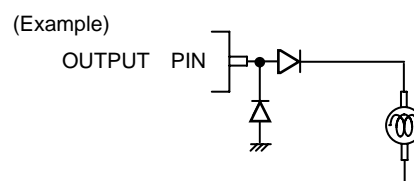

Notes

No copying or reproduction of this document, in part or in whole, is permitted without the consent of ROHM CO.,LTD.

The content specified herein is subject to change for improvement without notice.

The content specified herein is for the purpose of introducing ROHM's products (hereinafter "Products"). If you wish to use any such Product, please be sure to refer to the specifications, which can be obtained from ROHM upon request.

Examples of application circuits, circuit constants and any other information contained herein illustrate the standard usage and operations of the Products. The peripheral conditions must be taken into account when designing circuits for mass production.

Great care was taken in ensuring the accuracy of the information specified in this document. However, should you incur any damage arising from any inaccuracy or misprint of such information, ROHM shall bear no responsibility for such damage.

The technical information specified herein is intended only to show the typical functions of and examples of application circuits for the Products. ROHM does not grant you, explicitly or implicitly, any license to use or exercise intellectual property or other rights held by ROHM and other parties. ROHM shall bear no responsibility whatsoever for any dispute arising from the use of such technical information.

The Products specified in this document are intended to be used with general-use electronic equipment or devices (such as audio visual equipment, office-automation equipment, communication devices, electronic appliances and amusement devices).

The Products are not designed to be radiation tolerant.

While ROHM always makes efforts to enhance the quality and reliability of its Products, a Product may fail or malfunction for a variety of reasons.

Please be sure to implement in your equipment using the Products safety measures to guard against the possibility of physical injury, fire or any other damage caused in the event of the failure of any Product, such as derating, redundancy, fire control and fail-safe designs. ROHM shall bear no responsibility whatsoever for your use of any Product outside of the prescribed scope or not in accordance with the instruction manual.

The Products are not designed or manufactured to be used with any equipment, device or system which requires an extremely high level of reliability the failure or malfunction of which may result in a direct threat to human life or create a risk of human injury (such as a medical instrument, transportation equipment, aerospace machinery, nuclear-reactor controller, fuel-controller or other safety device). ROHM shall bear no responsibility in any way for use of any of the Products for the above special purposes. If a Product is intended to be used for any such special purpose, please contact a ROHM sales representative before purchasing.

If you intend to export or ship overseas any Product or technology specified herein that may be controlled under the Foreign Exchange and the Foreign Trade Law, you will be required to obtain a license or permit under the Law.

Thank you for your accessing to ROHM product informations.

More detail product informations and catalogs are available, please contact your nearest sales office.

ROHM Customer Support System

THE AMERICAS / EUROPE / ASIA / JAPAN

www.rohm.com

Contact us : webmaster@rohm.co.jp