

iC-PT 3325

6-CH. PHASED ARRAY OPTO ENCODER (33-2500)

preliminary



Rev A4, Page 1/10

FEATURES

- Monolithic photodiode array with excellent signal matching
- Very compact size for small encoders
- Moderate track pitch for relaxed assembly tolerances
- Low noise signal amplifiers with high EMI tolerance
- Single-pin programming of 3 operating modes: analog, digital, and x2 interpolation
- Ungated/gated Z index signal (1 T, 0.5 T)
- Complementary outputs: A, B, Z and NA, NB, NZ
- U, V, W commutation signals, analog and digital
- All outputs +/- 4 mA push-pull, current-limited and short-circuit-proof
- LED power control with 40 mA high-side driver
- Single 3.5 V to 5.5 V operation, low power consumption
- Operating temperature range of -40 to +85 °C (optional -40 to +120 °C)
- Suitable code disc: PT5S 33-2500 (glass)
- OD \varnothing 33.2 mm, ID \varnothing 13.0 mm, optical radius 14.5 mm, 2500 ppr and 4 ppr commutation (90°)

APPLICATIONS

- Incremental encoder
- BLDC motor commutation

PACKAGES

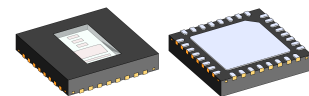

optoQFN32-5x5
5 mm x 5 mm x 0.9 mm

BLOCK DIAGRAM

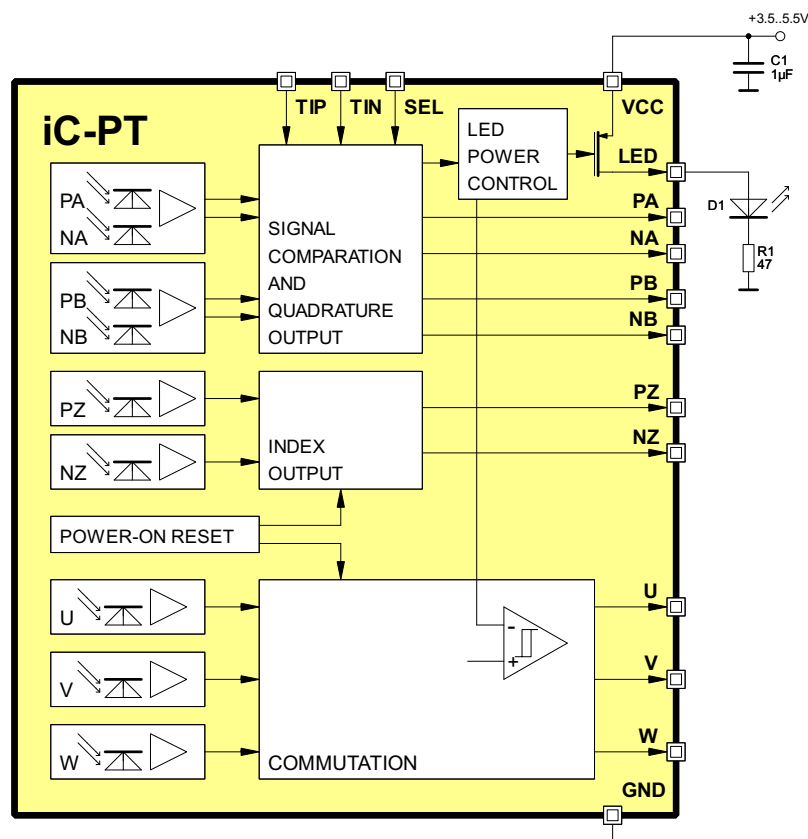

iC-PT 3325

6-CH. PHASED ARRAY OPTO ENCODER (33-2500)

preliminary



Rev A4, Page 2/10

DESCRIPTION

iC-PT 3325 is an optical sensor IC with integrated photosensors whose signals are converted into voltages by low-noise transimpedance amplifiers. Precise voltage comparators with hysteresis are used to generate the digital signals, supplied to the output pins via differential +/- 4 mA push-pull drivers.

The built-in LED power control with its 40 mA driver stage permits a direct connection of the encoder LED. Regardless of aging or changes in temperature the received optical power is kept constant. An external resistor presets the photocurrent operating point and thus the desired illumination level.

Selection input SEL chooses for three different operating modes: regular A/B operation, A/B operation with 2-fold interpolation, or analog operation. With analog operation the amplified signal voltages are

available at the outputs for inspection and monitoring encoder assembly.

Typical applications of iC-PT devices are incremental encoders for motor feedback and commutation. To this end, device version iC-PT 3325 provides differential A/B tracks and a differential index track, each consisting of multiple photo sensors. The layout of the signal amplifiers is such that there is an excellent paired channel matching, eliminating the needs for signal calibration in most cases.

Additionally, three more tracks are provided to generate motor commutation information for the U, V and W outputs, for instance with 90 degree phase shift to operate 4-phase brushless motors (period count and phase shift can be varied by the code disc applied).

iC-PT 3325

6-CH. PHASED ARRAY OPTO ENCODER (33-2500)

preliminary



Rev A4, Page 3/10

PACKAGES

PAD LAYOUT

Chip size 2.88 mm x 3.37 mm

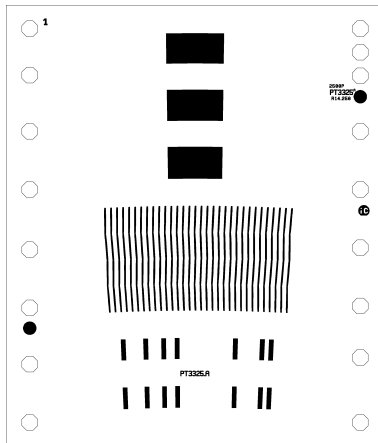

PAD FUNCTIONS

No. Name Function

See pin configuration.

PIN CONFIGURATION

oQFN32-5x5 (5 mm x 5 mm)

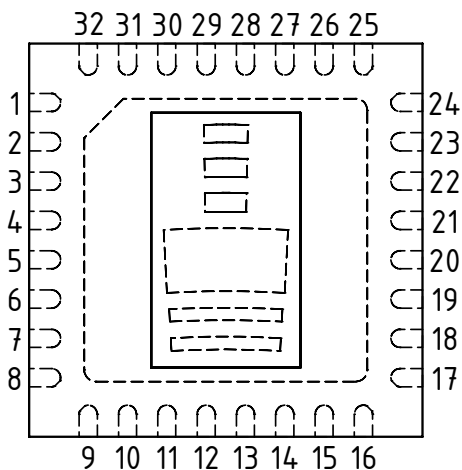

PIN FUNCTIONS

No. Name Function

1	VCC	+3.5..5.5 V Supply Voltage
2	LED	LED Controller, High-Side Current Source Output
3	PA	Push-Pull Output A+ / Test Sig. Sin+
4	NA	Push-Pull Output A- / Test Sig. Sin-
5	PB	Push-Pull Output B+ / Test Sig. Cos+
6	NB	Push-Pull Output B- / Test Sig. Cos-
7	PZ	Push-Pull Output Z+ / Test Signal Z+
8	NZ	Push-Pull Output Z- / Test Signal Z-
9..16	n.c.	
17	SEL	Op. Mode Selection Input: lo = digital hi = x2 interpolated open = analog (alignment aid)
18	W	Push-Pull Output W / Test Signal W
19	TIN	Negative Test Current Input
20	V	Push-Pull Output V / Test Signal V
21	TIP	Positive Test Current Input
22	U	Push-Pull Output U / Test Signal U
23	n.c.	
24	GND	Ground
25..32	n.c.	
	BP	Backside Paddle

Pin numbers marked n.c. are not in use. The backside paddle is not intended as an electrical connection point; when used as shield a single link to GND is permissible. The test pins TIP and TIN may remain unconnected. Capacitive pin loads must be avoided when using the analog test signals for alignment purposes.

iC-PT 3325

6-CH. PHASED ARRAY OPTO ENCODER (33-2500)

preliminary



Rev A4, Page 4/10

PACKAGE DIMENSIONS

RECOMMENDED PCB-FOOTPRINT

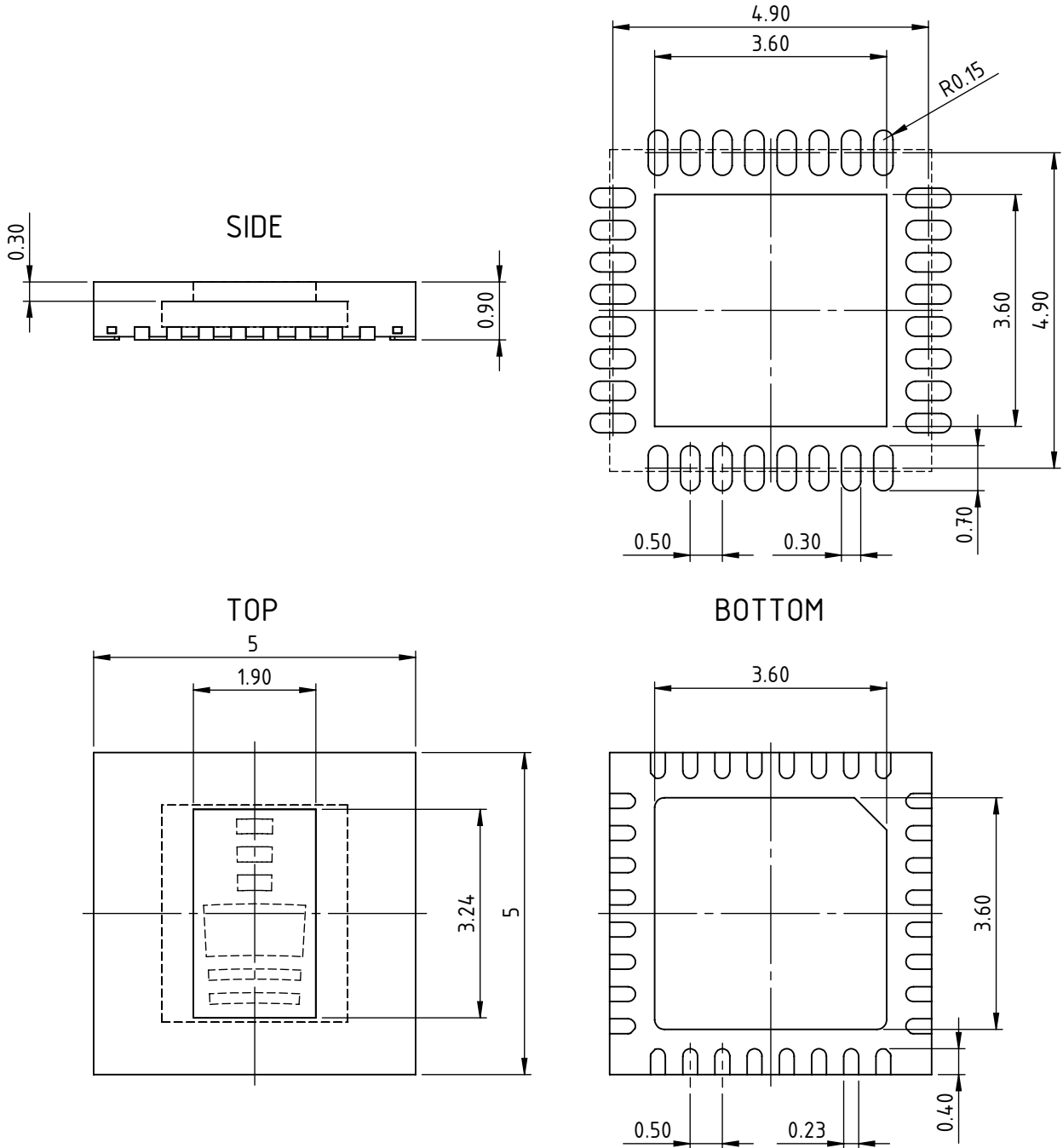

dra_pt33xx-oqfn32-2_pack_1, 10:1

Maximum molding excess +20 μm / -200 μm versus surface of glass.
All dimensions given in mm.

iC-PT 3325

6-CH. PHASED ARRAY OPTO ENCODER (33-2500)

preliminary



Rev A4, Page 5/10

ABSOLUTE MAXIMUM RATINGS

These ratings do not imply operating conditions; functional operation is not guaranteed. Beyond these ratings device damage may occur.

Item No.	Symbol	Parameter	Conditions	Limits		Unit
				Min.	Max.	
G001	VCC	Supply Voltage		-0.3	6	V
G002	I(VCC)	Current in VCC		-20	20	mA
G003	V()	Voltage at Output Pins PA, NA, PB, NB, PZ, NZ, U, V, W		-0.3	VCC + 0.3	V
G004	I()	Current in Output Pins PA, NA, PB, NB, PZ, NZ, U, V, W		-20	20	mA
G005	V()	Voltage at LED		-0.3	VCC + 0.3	V
G006	I()	Current in LED		-120	20	mA
G007	V()	Voltage at TIP, TIN, SEL		-0.3	VCC + 0.3	V
G008	I()	Current in TIP, TIN, SEL		-20	20	mA
G009	Vd()	ESD Susceptibility, all pins	HBM, 100 pF discharged through 1.5 kΩ		2	kV
G010	Tj	Junction Temperature		-40	150	°C
G011	Ts	Chip-Storage Temperature Range		-40	150	°C

THERMAL DATA

Item No.	Symbol	Parameter	Conditions	Limits			Unit
				Min.	Typ.	Max.	
T01	Ta	Operating Ambient Temperature Range (extended range on request)		-40		85	°C
T02	Ts	Permissible Storage Temperature Range		-40		85	°C
T03	Tpk	Soldering Peak Temperature	tpk < 20 s, convection reflow tpk < 20 s, vapor phase soldering MSL 5A (max. floor live 24 h at 30 °C and 60 % RH); Please refer to customer information file No. 7 for details.			245 230	°C °C

All voltages are referenced to ground unless otherwise stated.

All currents flowing into the device pins are positive; all currents flowing out of the device pins are negative.

iC-PT 3325

6-CH. PHASED ARRAY OPTO ENCODER (33-2500)

preliminary



Rev A4, Page 6/10

ELECTRICAL CHARACTERISTICS

Operating conditions: VCC = 3.5...5.5 V, Tj = -40...125 °C, λLED = λr = 740 nm, unless otherwise noted

Item No.	Symbol	Parameter	Conditions				Unit
				Min.	Typ.	Max.	
Total Device							
001	VCC	Permissible Supply Voltage		3.5		5.5	V
002	I(VCC)	Supply Current in VCC	no load, photocurrents within op. range		3	10	mA
003	Vc(lo)	Clamp-Voltage lo at all pins	I() = -4 mA, versus GND	-1.2		-0.3	V
004	Vc(hi)	Clamp-Voltage hi at all pins	I() = 4 mA			11	V
005	Vc(hi)	Clamp-Voltage hi at LED, PA, NA, PB, NB, PZ, NZ, U, V, W	I() = 4 mA, versus VCC	0.3		1.2	V
006	Vc(hi)	Clamp-Voltage hi at SEL, TIP, TIN	I() = 4 mA, versus VCC	0.7		2.2	V
Photosensors							
101	λar	Spectral Application Range	Se(λar) = 0.25 x S(λ)max	400		950	nm
102	λpk	Peak Sensitivity Wavelength			680		nm
103	Aph()	Radiant Sensitive Area	PA, PB, NA, NB (sum of segments) U, V, W (per segment) PZ, NZ (sum of segments)		0.072 0.1 0.038		mm ² mm ² mm ²
104	S(λr)	Spectral Sensitivity	λLED = 740 nm		0.5		A/W
105	S(λ)max	Maximum Spectral Sensitivity	λLED = λpk		0.55		A/W
106	E()mxpk	Permissible Irradiance	λLED = λpk, Vout() < Vout()mx; PA, PB, NA, NB U, V, W PZ, NZ		2.3 1.1 3.2		mW/ cm ² mW/ cm ² mW/ cm ²
Photocurrent Amplifiers							
201	Iph()	Permissible Photocurrent Operating Range		0		550	nA
202	η()r	Photo Sensitivity (light-to-voltage conversion ratio)	for PA, PB, NA, NB for PZ, NZ, U, V, W	0.1 0.2	0.3 0.4	0.5 0.6	V/μW V/μW
203	Z()	Equivalent Transimpedance Gain	Z = Vout() / Iph(), Tj = 27 °C; for PA, PB, NA, NB for PZ, NZ, U, V, W	0.56 0.66	0.75 1.0	1 1.36	MΩ MΩ
204	TCz	Temperature Coefficient of Transimpedance Gain			-0.12		%/°C
205	ΔZ()pn	Transimpedance Gain Matching	SEL open, P vs. N path per diff. channel	-0.2		0.2	%
206	ΔVout()	Dark Signal Matching of A, B	SEL open, output vs. output	-8		8	mV
207	ΔVout()	Dark Signal Matching of U, V, W	SEL open, output vs. output	-12		12	mV
208	ΔVout()	Dark Signal Matching of A, B, Z, U, V, W	SEL open, any output vs. any output	-24		24	mV
209	ΔVout()pn	Dark Signal Matching	SEL open, P vs. N path per diff. channel	-2.5		2.5	mV
211	fc(hi)	Cut-off Frequency (-3 dB)			400		kHz
Analog Outputs PA, NA, PB, NB, PZ, NZ, U, V, W							
301	Vout()mx	Maximum Output Voltage	illumination to E()mxpk	1.04	1.27	1.8	V
302	Vout()d	Dark Signal Level	load 100 kΩ vs. +2 V	640	770	985	mV
303	Vout()acmx	Maximum Signal Level	Vout()acmx = Vout()mx - Vout()d	0.3	0.5	0.75	V
304	Isc(hi)	Short-Circuit Current hi	SEL open, load current to ground	100	1800	3000	μA
305	Isc(lo)	Short-Circuit Current lo	SEL open, load current to IC	20	40	200	μA
306	Ri()	Internal Output Resistance	f = 1 kHz	250	750	2250	Ω

iC-PT 3325

6-CH. PHASED ARRAY OPTO ENCODER (33-2500)

preliminary



Rev A4, Page 7/10

ELECTRICAL CHARACTERISTICS

Operating conditions: VCC = 3.5...5.5 V, Tj = -40...125 °C, λLED = λr = 740 nm, unless otherwise noted

Item No.	Symbol	Parameter	Conditions				Unit
				Min.	Typ.	Max.	
Comparators							
401	Vt()hi	Upper Comparator Threshold	$I_{ph}()p \times Z()p > I_{ph}()n \times Z()n$, resp. $I_{ph}()p \times Z()p > \text{internal VREF}$	5	12	25	mV
402	Vt()lo	Lower Comparator Threshold	$I_{ph}()p \times Z()p < I_{ph}()n \times Z()n$, resp. $I_{ph}()p \times Z()p < \text{internal VREF}$	5	12	25	mV
403	Vt()hys	Comparator Hysteresis	$Vt()hys = Vt()hi - Vt()lo$	10	24	50	mV
LED Power Control							
501	Iop()	Permissible LED Output Current		-40		0	mA
502	Vs()hi	Saturation Voltage hi	$Vs()hi = VCC - V(\text{LED})$; I() = -40 mA	0.25	0.5	1	V
503	Isc()hi	Short-Circuit Current hi	V() = 0 V	-150		-50	mA
Digital Outputs PA, NA, PB, NB, PZ, NZ, U, V, W							
601	Vs()lo	Saturation Voltage lo	VCC = 4.5...5.5 V, I() = 4 mA, Tj = 70 °C			0.4	V
602	Vs()lo	Saturation Voltage lo	VCC = 4.5...5.5 V, I() = 4 mA, Tj = 85 °C			0.5	V
603	Vs()lo	Saturation Voltage lo	VCC = 3.5...4.5 V, I() = 4 mA			0.6	V
604	Isc()lo	Short-Circuit Current lo	V() = VCC	7		70	mA
605	Vs()hi	Saturation Voltage hi	$Vs()hi = VCC - V()$, I() = -4 mA; VCC = 4.5...5.5 V			0.4	V
606	Vs()hi	Saturation Voltage hi	$Vs()hi = VCC - V()$, I() = -4 mA; VCC = 3.5...4.5 V			0.6	V
607	Isc()hi	Short-Circuit Current hi	V() = 0 V	-70		-7	mA
Selection Input SEL							
701	Vt1()hi	Upper Threshold Voltage hi	for A/B mode with x2 interpolation	78	80	82	%VCC
702	Vt1()lo	Upper Threshold Voltage lo	for A/B mode with x2 interpolation	68	70	72	%VCC
703	Vt1()hys	Upper Threshold Hysteresis	$Vt1()hys = Vt1()hi - Vt1()lo$	8	10	12	%VCC
704	Vt2()hi	Lower Threshold Voltage hi	for A/B mode	28	30	32	%VCC
705	Vt2()lo	Lower Threshold Voltage lo	for A/B mode	18	20	22	%VCC
706	Vt2()hys	Lower Threshold Hysteresis	$Vt2()hys = Vt2()hi - Vt2()lo$	8	10	12	%VCC
707	V0()	Pin-Open Voltage	for analog mode	45	50	55	%VCC
708	Rpd()	Pull-Down Resistor	SEL to GND, V(SEL) = VCC	70	100	140	kΩ
709	Rpu()	Pull-Up Resistor	VCC to SEL, V(SEL) = 0 V	70	100	140	kΩ
710	Vpd()	Pull-Down Voltage vs. VCC/2	$Vpd() = V() - VCC/2$; I() = 0...5 μA			0.5	V
711	Vpu()	Pull-Up Voltage vs. VCC/2	$Vpu() = V() - VCC/2$; I() = -5...0 μA	-0.5			V
Test Circuit Inputs TIP, TIN							
801	I()test	Permissible Test Current Range	test mode active	10		600	μA
802	V()test	Test Pin Voltage	test mode active, I() = 200 μA	1.25	1.5	1.75	V
803	Ipd()	Test Pin Pull-Down Current	test mode not active, V() = 0.4 V	60	100	160	μA
804	Ipd()	Test Pin Pull-Down Current	V() = VCC	0.7	2	3	mA
805	It()on	Test Mode Activation Threshold		80	130	190	μA
806	CR()	Test Mode Current Ratio I()/Iph()	test mode active, I() = 200 μA	1500	3000	5000	
Power-On-Reset Circuit							
901	VCCon	Turn-on Threshold VCC (power-on release)	increasing voltage at VCC		2.6	3.45	V
902	VCCoff	Turn-off Threshold VCC (power-down reset)	decreasing voltage at VCC	1.4	2.4		V
903	VCChys	Threshold Hysteresis	$VCChys = VCCon - VCCoff$	50	170	300	mV
Index Gating Selection Input T1							
A01	Rpu()	Pull-Up Resistor	VCC to T1, V(T1) = 0V	85	125	750	kΩ

Z INDEX SIGNAL

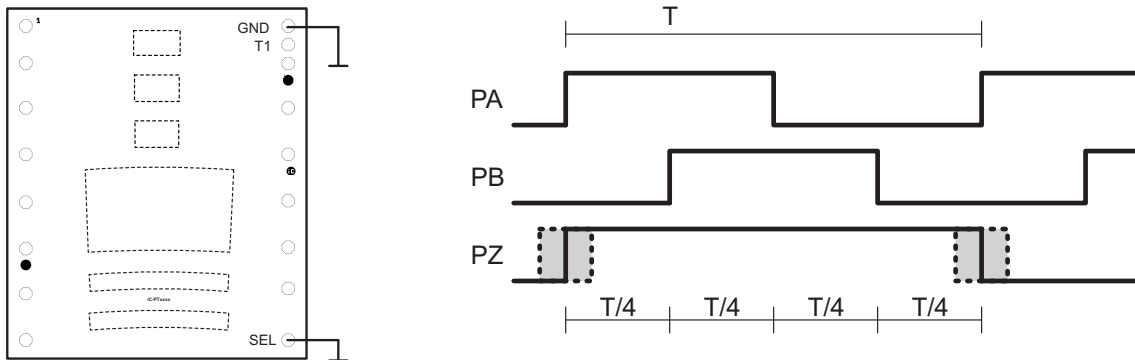

Figure 1: Ungated Z index signal at x1 interpolation (SEL = lo; T1 open)

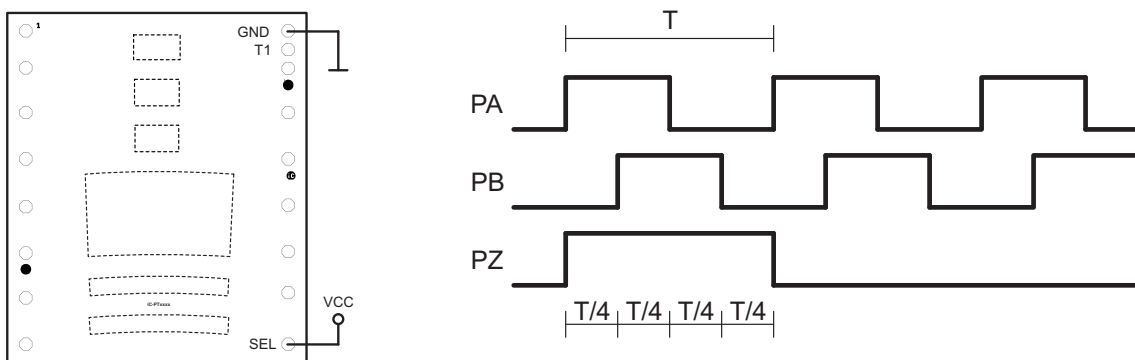

Figure 2: T gated Z index signal at x2 interpolation (SEL = hi; T1 open)

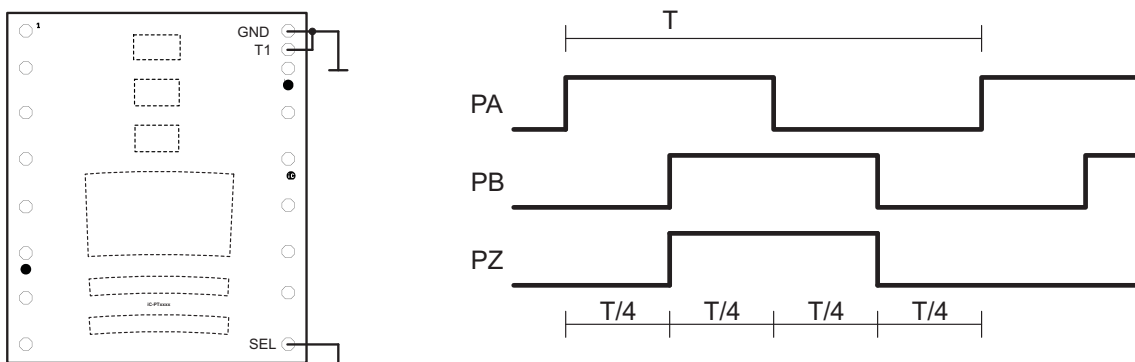

Figure 3: B gated Z index signal at x1 interpolation (SEL = lo; T1 = lo)

iC-PT 3325

6-CH. PHASED ARRAY OPTO ENCODER (33-2500)

preliminary



Rev A4, Page 10/10

ORDERING INFORMATION

Type	Package	Options	Order Designation
iC-PT3325	32-pin optoQFN, 5 mm x 5 mm, 0.9 mm thickness	glass lid Encoder Disc 2500 PPR +4 PPR, OD/ID \varnothing 33.2/13.0 mm, glass	iC-PT3325 oQFN32-5x5 PT5S 33-2500

For technical support, information about prices and terms of delivery please contact:

iC-Haus GmbH
Am Kuemmerling 18
D-55294 Bodenheim
GERMANY

Tel.: +49 (61 35) 92 92-0
Fax: +49 (61 35) 92 92-192
Web: <http://www.ichaus.com>
E-Mail: sales@ichaus.com

Appointed local distributors: http://www.ichaus.com/sales_partners