



# NPN POWER TRANSISTORS

COMPLEMENTARY TO THE D41D SERIES

## D40D Series

30 - 60 VOLTS  
1 AMP, 6.25 WATTS

The General Electric D40D is a power transistor designed for various specific and general purpose applications, such as: output and driver stages of amplifiers operating at frequencies from DC to greater than 1.0 MHz; series, shunt and switching regulators; low and high frequency inverters/converters; and many others.

### Features:

- High free-air power dissipation
- NPN complement to D41D PNP
- Low collector saturation voltage (0.5V typ. @ 1.0A  $I_C$ )
- Excellent linearity
- Fast Switching

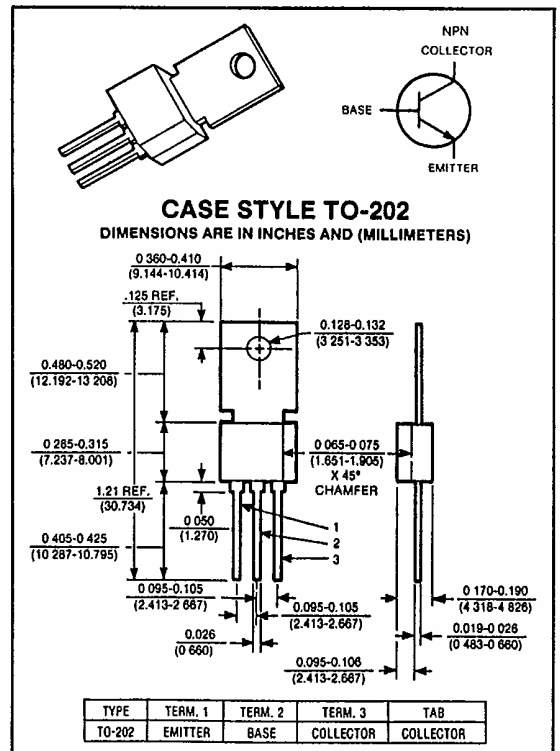

maximum ratings ( $T_A = 25^\circ\text{C}$ ) (unless otherwise specified)

RATING	SYMBOL	D40D1, 2	D40D4, 5	D40D7, 8	UNITS
Collector-Emitter Voltage	$V_{CEO}$	30	45	60	Volts
Collector-Emitter Voltage	$V_{CES}$	45	60	75	Volts
Emitter Base Voltage	$V_{EBO}$	5	5	5	Volts
Collector Current — Continuous	$I_C$	1	1	1	A
Peak <sup>(1)</sup>	$I_{CM}$	1.5	1.5	1.5	
Base Current — Continuous	$I_B$	.5	.5	.5	A
Total Power Dissipation @ $T_A = 25^\circ\text{C}$ @ $T_C = 25^\circ\text{C}$	$P_D$	1.67 6.25	1.67 6.25	1.67 6.25	Watts
Operating and Storage Junction Temperature Range	$T_J, T_{stg}$	-55 to +150	-55 to +150	-55 to +150	$^\circ\text{C}$

### thermal characteristics

Thermal Resistance, Junction to Ambient	$R_{\theta JA}$	75	75	75	$^\circ\text{C/W}$
Thermal Resistance, Junction to Case	$R_{\theta JC}$	20	20	20	$^\circ\text{C/W}$
Maximum Lead Temperature for Soldering Purposes: $\frac{1}{16}$ " from Case for 5 Seconds	$T_L$	+260	+260	+260	$^\circ\text{C}$

(1) Pulse Test Pulse Width = 300ms Duty Cycle  $\leq$  2%.

electrical characteristics ( $T_C = 25^\circ\text{C}$ ) (unless otherwise specified)

CHARACTERISTIC	SYMBOL	MIN	TYP	MAX	UNIT
----------------	--------	-----	-----	-----	------

off characteristics<sup>(1)</sup>

Collector-Emitter Sustaining Voltage ( $I_C = 10\text{mA}$ )	D40D1, 2 D40D4, 5 D40D7, 8	$V_{CEO(sus)}$	30 45 60	— — —	— — —	Volts
Collector Cutoff Current ( $V_{CE} = \text{Rated } V_{CEO}$ ) ( $V_{CE} = \text{Rated } V_{CES}$ )	$T_C = 25^\circ\text{C}$ $T_C = 150^\circ\text{C}$	$I_{CES}$	— —	— 1.0	— —	$\mu\text{A}$
Emitter Cutoff Current ( $V_{EB} = 5\text{V}$ )		$I_{EBO}$	—	—	0.1	$\mu\text{A}$

second breakdown

Second Breakdown with Base Forward Biased	FBSOA	SEE FIGURE 4
---	-------	--------------

on characteristics

DC Current Gain ( $I_C = 100\text{mA}$ , $V_{CE} = 2\text{V}$ )	D40D1, 4, 7 D40D2, 5, 8	$h_{FE}$	50 120	— —	150 360	—
( $I_C = 1\text{A}$ , $V_{CE} = 2\text{V}$ )	D40D1, 4, 7 D40D2 D40D5, 8	$h_{FE}$	10 20 10	— — —	— — —	—
Collector-Emitter Saturation Voltage ( $I_C = 500\text{mA}$ , $I_B = 50\text{mA}$ )	D40D1, 2, 4, 5 D40D7, 8	$V_{CE(sat)}$	— —	— —	0.5 1.0	Volts
Base-Emitter Saturation Voltage ( $I_C = 500\text{mA}$ , $I_B = 50\text{mA}$ )		$V_{BE(sat)}$	—	—	1.5	Volts

dynamic characteristics

Collector Capacitance ( $V_{CB} = 10\text{V}$ , $f = 1\text{MHz}$ )		$C_{CBO}$	—	8	—	pF
Current-Gain — Bandwidth Product ( $I_C = 20\text{mA}$ , $V_{CE} = 10\text{V}$ )		$f_T$	—	200	—	MHz

switching characteristics

Resistive Load						
Delay Time + Rise Time	$I_C = 1\text{A}$ , $I_{B1} = I_{B2} = 0.1\text{A}$ $V_{CC} = 30\text{V}$ , $t_p = 25\ \mu\text{sec}$	$t_d + t_r$	—	25	—	nS
Storage Time		$t_s$	—	200	—	
Fall Time		$t_f$	—	50	—	

(1) Pulse Test PW = 300ms Duty Cycle  $\leq 2\%$ .

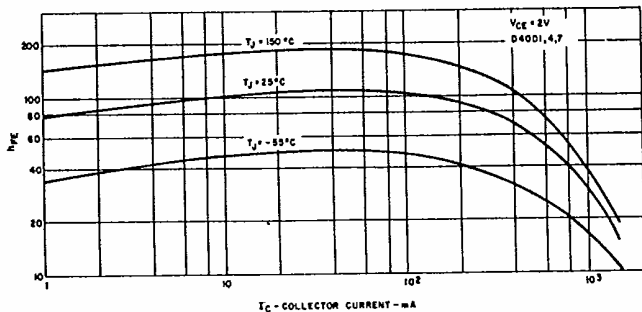

FIG. 1

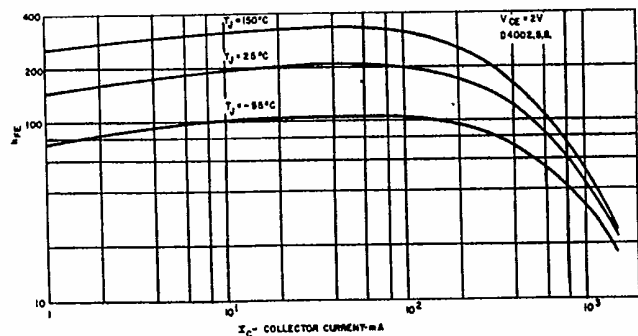

FIG. 2

TYPICAL  $h_{FE}$  VS  $I_C$

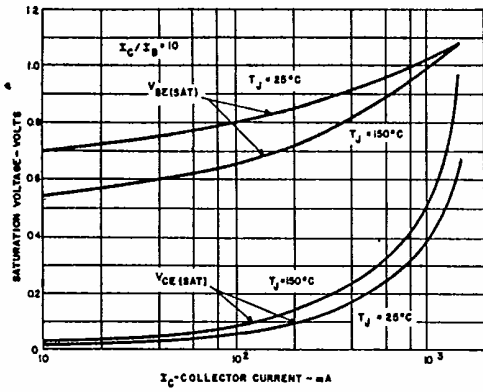

FIG. 3 TYPICAL SATURATION VOLTAGE CHARACTERISTICS

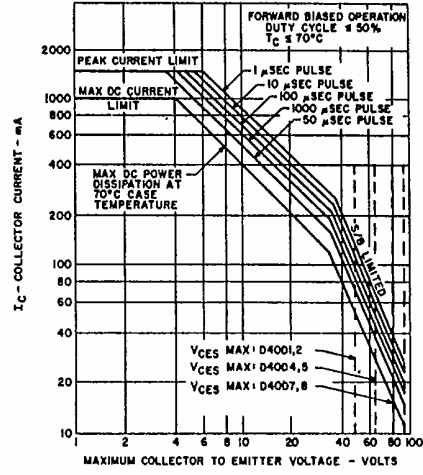

FIG. 4 SAFE REGION OF OPERATION

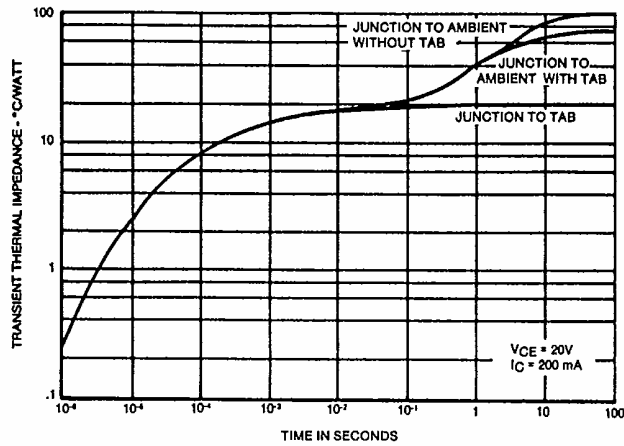

FIG. 5 MAXIMUM TRANSIENT THERMAL IMPEDANCE