

250V Low Charge Injection 8-Channel High Voltage Analog Switch

Features

- ▶ HVCMOS® technology for high performance
- ▶ Very low quiescent power dissipation -10µA
- ▶ Low parasitic capacitances
- ▶ DC to 10MHz analog signal frequency
- ▶ -60dB typical output off isolation at 5MHz
- ▶ -60dB typical off-isolation at 5MHz
- ▶ CMOS logic circuitry for low power
- ▶ Excellent noise immunity
- ▶ On-chip shift register, latch and clear logic circuitry
- ▶ Flexible high voltage supplies
- ▶ Surface mount packages

Applications

- ▶ Medical ultrasound imaging
- ▶ Non-destructive evaluation
- ▶ Inkjet printer heads
- ▶ Optical MEMS modules

General Description

The Supertex HV214 is a low charge injection 8-channel high voltage analog switch integrated circuit (IC) intended for use in applications requiring high voltage switching controlled by low voltage control signals, such as medical ultrasound imaging, piezoelectric transducer drivers, inkjet printer heads and optical MEMS modules.

Input data is shifted into an 8-bit shift register that can then be retained in an 8-bit latch. To reduce any possible clock feedthrough noise, the latch enable bar should be left high until all bits are clocked in. Data are clocked in during the rising edge of the clock. Using HVCMOS® technology, this device combines high voltage bilateral DMOS switches and low power CMOS logic to provide efficient control of high voltage analog signals.

The device is suitable for various combinations of high voltage supplies, e.g., V_{PP}/V_{NN} : +40V/-210V, +125V/-125V, +210V/-40V.

Block Diagram

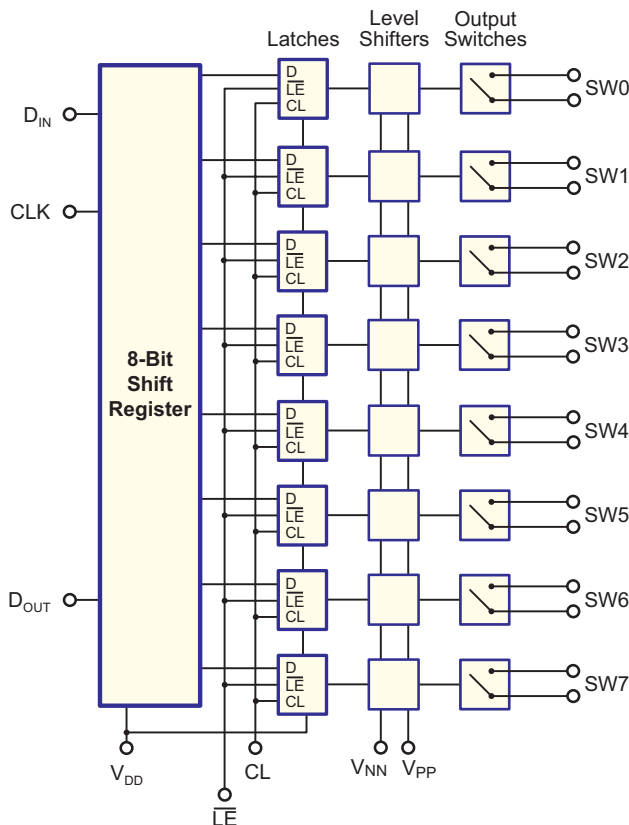

Ordering Information

Package Options		
Device	28-Lead PLCC	48-Lead LQFP/TQFP(1.4mm)
HV214	HV214PJ	HV214FG
	HV214PJ-G	HV214FG-G

-G indicates the part is RoHS compliant (Green)



Absolute Maximum Ratings

Parameter	Value
V_{DD} logic power supply voltage	-0.5V to +15V
$V_{PP} - V_{NN}$ supply voltage	260V
V_{PP} positive high voltage supply	-0.5V to $V_{NN} + 250V$
V_{NN} negative high voltage supply	+0.5V to -260V
Logic input voltages	-0.5V to $V_{DD} + 0.3V$
Analog signal range	V_{NN} to V_{PP}
Peak analog signal current/channel	2.5A
Storage temperature	-65°C to +150°C
Power dissipation:	
28-Lead PLCC	1.2W
48-Lead LQFP/TQFP (1.4mm)	1.0W

Absolute Maximum Ratings are those values beyond which damage to the device may occur. Functional operation under these conditions is not implied. Continuous operation of the device at the absolute rating level may affect device reliability. All voltages are referenced to device ground.

Operating Conditions

Symbol	Parameter	Value
V_{DD}	Logic power supply voltage	4.5V to 13.2V
V_{PP}	Positive high voltage supply	40V to $V_{NN} + 250V$
V_{NN}	Negative high voltage supply	-40V to -210V
V_{IH}	High level input logic voltage	$V_{DD} - 1.5V$ to V_{DD}
V_{IL}	Low-level input logic voltage	0V to 1.5V
V_{SIG}	Analog signal voltage peak-to-peak	$V_{NN} + 10V$ to $V_{PP} - 10V$
T_A	Operating free air temperature	0°C to 70°C

Pin Configurations

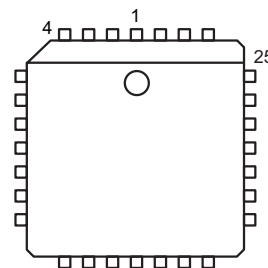

28-Lead (J) PLCC (PJ)
(top view)

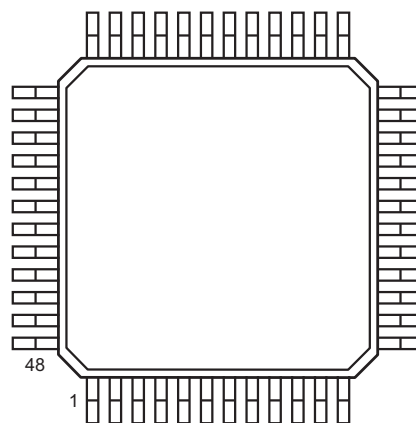

48-Lead LQFP (FG)
(7x7x1.4mm)
(top view)

Product Marking

Top Marking



YY = Year Sealed
WW = Week Sealed
L = Lot Number
C = Country of Origin
A = Assembler ID*

Bottom Marking

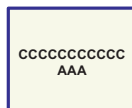

— = "Green" Packaging
*May be part of top marking

28-Lead PLCC (PJ)

Top Marking

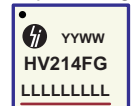

YY = Year Sealed
WW = Week Sealed
L = Lot Number
C = Country of Origin
A = Assembler ID*

Bottom Marking



— = "Green" Packaging
*May be part of top marking

48-Lead LQFP (FG)

DC Electrical Characteristics ($T_A = 25^\circ\text{C}$, over recommended operating conditions unless otherwise noted)

Sym	Parameter	Min	Typ	Max	Units	Conditions
R_{ONS}	Small signal switch on-resistance	-	-	55	Ω	$I_{\text{SIG}} = 5.0\text{mA}$ $V_{\text{PP}} = +40\text{V}$
		-	-	49		$I_{\text{SIG}} = 200\text{mA}$ $V_{\text{NN}} = -160\text{V}$
		-	-	42		$I_{\text{SIG}} = 5.0\text{mA}$ $V_{\text{PP}} = +125\text{V}$
		-	-	36		$I_{\text{SIG}} = 200\text{mA}$ $V_{\text{NN}} = -100\text{V}$
		-	-	38		$I_{\text{SIG}} = 5.0\text{mA}$ $V_{\text{PP}} = +210\text{V}$
		-	-	32		$I_{\text{SIG}} = 200\text{mA}$ $V_{\text{NN}} = -40\text{V}$
ΔR_{ONS}	Small signal switch On-resistance matching	-	-	20	%	$I_{\text{SIG}} = 5\text{mA}$, $V_{\text{PP}} = +125\text{V}$, $V_{\text{NN}} = -125\text{V}$
R_{ONL}	Large signal switch On-resistance	-	23	-	Ω	$V_{\text{SIG}} = V_{\text{PP}} - 10\text{V}$, $I_{\text{SIG}} = 1\text{A}$
I_{SOL}	Switch off leakage per switch	-	-	10	μA	$V_{\text{SIG}} = V_{\text{PP}} - 10\text{V}$ & $V_{\text{NN}} + 10\text{V}$
	DC offset switch off	-	-	300	mV	$R_{\text{LOAD}} = 100\text{K}\Omega$
	DC offset switch on	-	-	500	mV	$R_{\text{LOAD}} = 100\text{K}\Omega$
I_{PPQ}	Quiescent V_{PP} supply current	-	-	50	μA	All switches off
I_{NNQ}	Quiescent V_{NN} supply current	-	-	-50	μA	All switches off
I_{PPQ}	Quiescent V_{PP} supply current	-	-	50	μA	All switches on, $I_{\text{SW}} = 5.0\text{mA}$
I_{NNQ}	Quiescent V_{NN} supply current	-	-	-50	μA	All switches on, $I_{\text{SW}} = 5.0\text{mA}$
	Switch output peak current	-	-	2.0	A	V_{SIG} duty cycle 0.1%
f_{SW}	Output switch frequency	-	-	50	kHz	Duty cycle = 50%
I_{PP}	Average V_{PP} supply current	-	-	7.0	mA	$V_{\text{PP}} = +40\text{V}$ $V_{\text{NN}} = -160\text{V}$
		-	-	5.0		$V_{\text{PP}} = +100\text{V}$ $V_{\text{NN}} = -100\text{V}$
		-	-	5.0		$V_{\text{PP}} = +160\text{V}$ $V_{\text{NN}} = -40\text{V}$
I_{NN}	Average V_{NN} supply current	-	-	-7.0	mA	$V_{\text{PP}} = +40\text{V}$ $V_{\text{NN}} = -160\text{V}$
		-	-	-5.0		$V_{\text{PP}} = +100\text{V}$ $V_{\text{NN}} = -100\text{V}$
		-	-	-5.0		$V_{\text{PP}} = +160\text{V}$ $V_{\text{NN}} = -40\text{V}$
I_{DD}	Average V_{DD} supply current	-	-	10	mA	$f_{\text{CLK}} = 5\text{MHz}$, $V_{\text{DD}} = 5.0\text{V}$
I_{DDQ}	Quiescent V_{DD} supply current	-	-	4.0	μA	---
I_{SOR}	Data out source current	45	-	-	mA	$V_{\text{OUT}} = V_{\text{DD}} - 0.7\text{V}$
I_{SINK}	Data out sink current	45	-	-	mA	$V_{\text{OUT}} = 0.7\text{V}$
C_{IN}	Large input capacitance	-	-	10	pF	---
T_A	Ambient temperature range	0	-	70	$^\circ\text{C}$	---

AC Electrical Characteristics ($V_{DD} = 5.0V$, $T_A = 25^\circ C$, over recommended operating conditions unless otherwise noted)

Sym	Parameter	Min	Typ	Max	Units	Conditions
t_{SD}	Set-up time before \overline{LE} rises	150	-	-	ns	---
t_{WLE}	Time width of \overline{LE}	150	-	-	ns	---
t_{DO}	Clock delay time to data out	-	-	150	ns	---
t_{WCL}	Time width of CL	150	-	-	ns	---
t_{SU}	Set-up time data to clock	15	8.0	-	ns	---
t_H	Hold time data from clock	35	-	-	ns	---
f_{CLK}	Clock frequency	-	-	5.0	MHz	50% duty cycle, $f_{DATA} = f_{CLK}/2$
t_R, t_F	Clock rise and fall times	-	-	50	ns	---
T_{ON}	Turn-on time	-	-	5.0	μs	$V_{SIG} = V_{PP} - 10V, R_{LOAD} = 10K\Omega$
T_{OFF}	Turn-off time	-	-	5.0	μs	$V_{SIG} = V_{PP} - 10V, R_{LOAD} = 10K\Omega$
dv/dt	Maximum V_{SIG} slew rate	-	-	20	V/ns	$V_{PP} = +40V, V_{NN} = -160V$
		-	-	20		$V_{PP} = +125V, V_{NN} = -100V$
		-	-	20		$V_{PP} = +210V, V_{NN} = -40V$
KO	Off isolation	-30	-	-	dB	F = 5MHz, 1K Ω /15pF load
		-58	-	-		F = 5MHz, 50 Ω load
K_{CR}	Switch crosstalk	-60	-	-	dB	F = 5MHz, 50 Ω load
I_{ID}	Output switch isolation diode current	-	-	300	mA	300ns pulse width, 2% duty cycle
$C_{SG(OFF)}$	Off capacitance SW to GND	5.0	12	17	pF	0V, f = 1MHz
$C_{SG(ON)}$	On capacitance SW to GND	25	38	50	pF	0V, f = 1MHz
$+V_{SPK}$	Output voltage spike	-	-	200	mV	$V_{PP} = +40V, V_{NN} = -210V, R_{LOAD} = 50\Omega$
$-V_{SPK}$		-	-	200		
$+V_{SPK}$		-	-	200		$V_{PP} = +100V, V_{NN} = -125V, R_{LOAD} = 50\Omega$
$-V_{SPK}$		-	-	200		
$+V_{SPK}$		-	-	200		$V_{PP} = +160V, V_{NN} = -40V, R_{LOAD} = 50\Omega$
$-V_{SPK}$		-	-	200		

Truth Table

Data in 8-Bit Shift Register								\overline{LE}	CL	Output Switch State							
D0	D1	D2	D3	D4	D5	D6	D7			SW0	SW1	SW2	SW3	SW4	SW5	SW6	SW7
L								L	L	OFF							
H								L	L	ON							
	L							L	L		OFF						
	H							L	L		ON						
		L						L	L			OFF					
		H						L	L			ON					
			L					L	L				OFF				
			H					L	L				ON				
				L				L	L					OFF			
				H				L	L					ON			
					L			L	L						OFF		
					H			L	L						ON		
						L		L	L							OFF	
						H		L	L							ON	
							L	L	L								OFF
							H	L	L								ON
X	X	X	X	X	X	X	X	H	L	Hold Previous State							
X	X	X	X	X	X	X	X	X	H	OFF	OFF	OFF	OFF	OFF	OFF	OFF	OFF

Notes:

1. The eight switches operate independently.
2. Serial data is clocked in on the L→H transition CLK.
3. The switches go to a state retaining their present condition at the rising edge of \overline{LE} . When \overline{LE} is low the shift register data flows through the latch.
4. D_{OUT} is high when switch 7 is on.
5. Shift register clocking has no effect on the switch states if \overline{LE} is H.
6. The clear input overrides all other inputs.

Logic Timing Waveforms

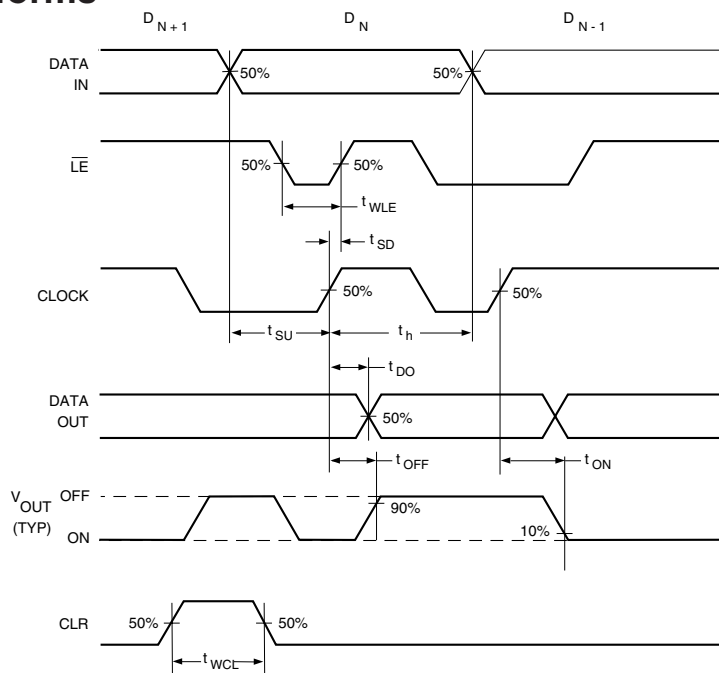

Test Circuits

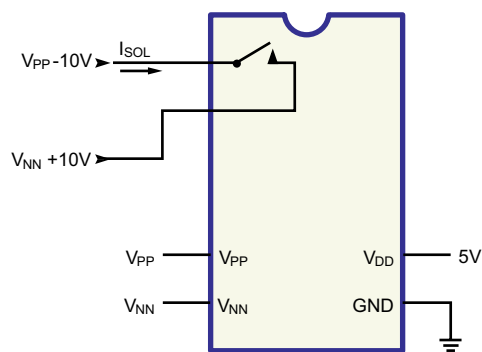

Switch OFF Leakage

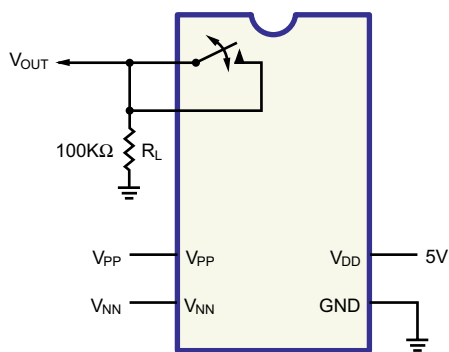

DC Offset ON/OFF

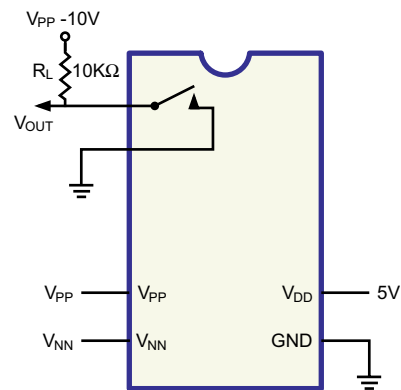

T_{ON}/T_{OFF} Test Circuit

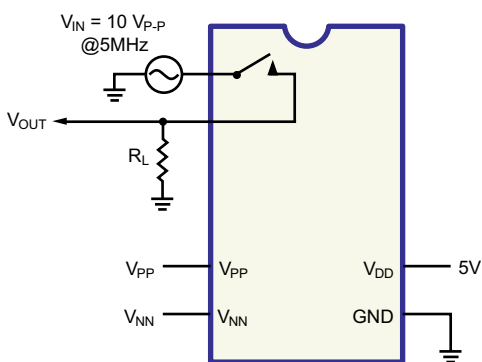

$K_O = 20 \text{Log} \frac{V_{OUT}}{V_{IN}}$
OFF Isolation

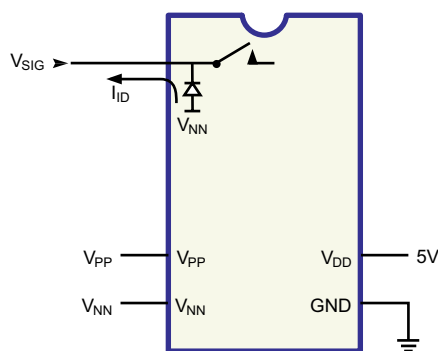

Isolation Diode Current

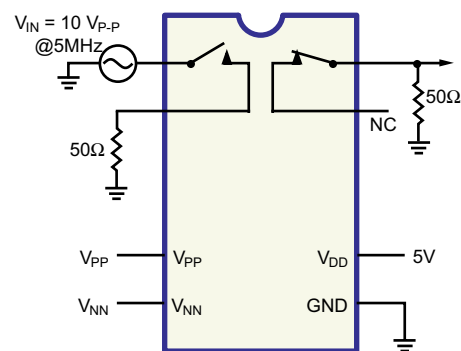

$K_{CR} = 20 \text{Log} \frac{V_{OUT}}{V_{IN}}$
Crosstalk

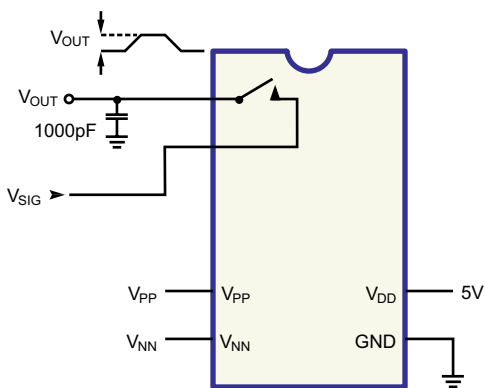

$Q = 1000 \text{pF} \times V_{OUT}$
Charge Injection

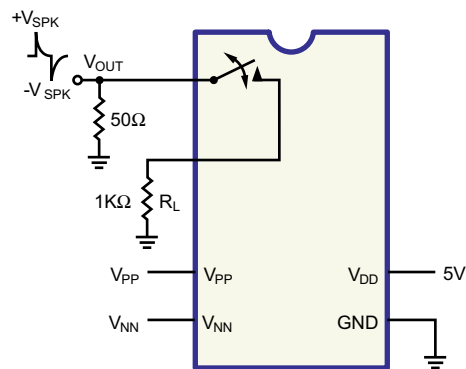

Output Voltage Spike

28-Lead (J-Lead) PLCC (PJ) Pin Description

Pin	Function	Pin	Function	Pin	Function	Pin	Function
1	SW3	8	SW0	15	NC	22	SW7
2	SW3	9	NC	16	D _{IN}	23	SW6
3	SW2	10	V _{PP}	17	CLK	24	SW6
4	SW2	11	NC	18	$\overline{\text{LE}}$	25	SW5
5	SW1	12	V _{NN}	19	CL	26	SW5
6	SW1	13	GND	20	D _{OUT}	27	SW4
7	SW0	14	V _{DD}	21	SW7	28	SW4

48-Lead LQFP/TQFP (FG) Pin Description

Pin	Function	Pin	Function	Pin	Function	Pin	Function
1	SW5	13	NC	25	V _{NN}	37	D _{OUT}
2	NC	14	SW2	26	NC	38	NC
3	SW4	15	NC	27	NC	39	SW7
4	NC	16	SW1	28	GND	40	NC
5	SW4	17	NC	29	V _{DD}	41	SW7
6	NC	18	SW1	30	NC	42	NC
7	NC	19	NC	31	NC	43	SW6
8	SW3	20	SW0	32	NC	44	NC
9	NC	21	NC	33	D _{IN}	45	SW6
10	SW3	22	SW0	34	CLK	46	NC
11	NC	23	NC	35	$\overline{\text{LE}}$	47	SW5
12	SW2	24	V _{PP}	36	CLR	48	NC

Power Up/Down Sequence:

1. Power up/down sequence is arbitrary except GND must be powered-up first and powered-down last.
2. V_{SIG} must be V_{NN} ≤ V_{SIG} ≤ V_{PP} or floating during power up/down transition.
3. Rise and fall times of power supplies V_{DD}, V_{PP}, and V_{NN} should not be less than 1.0msec.

28-Lead PLCC Package Outline (PJ)

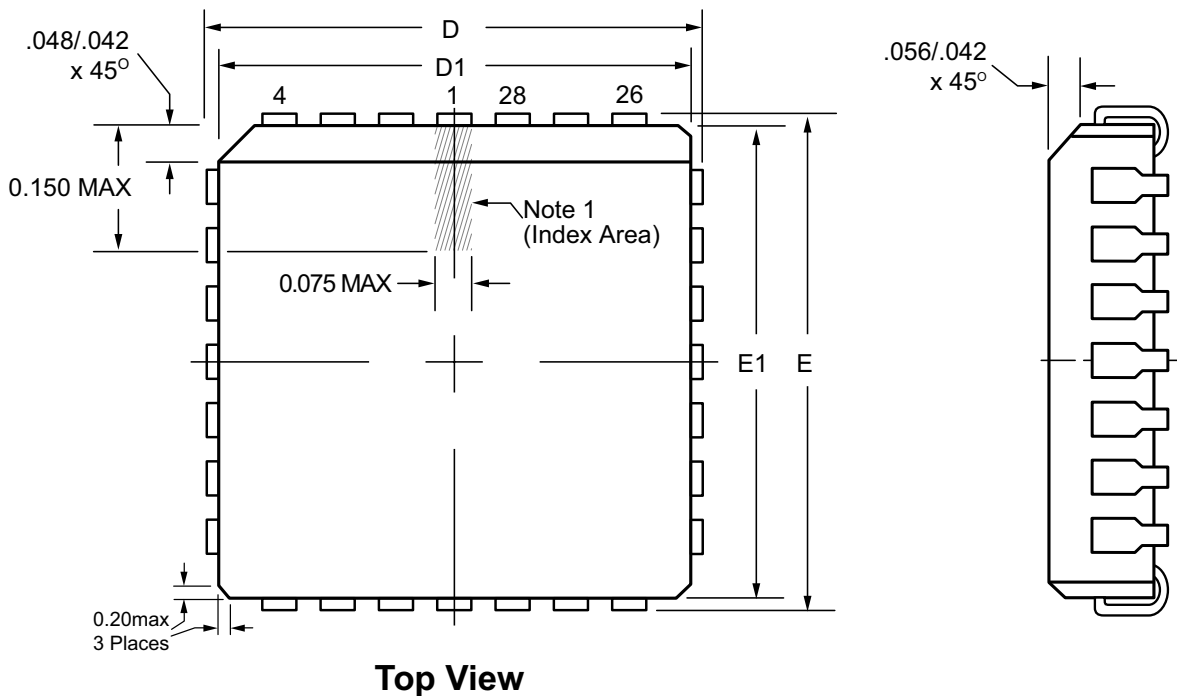

Top View

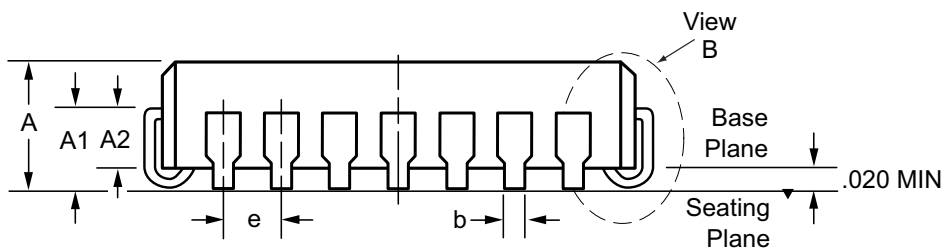

Side View

Note 1:

A Pin 1 identifier must be located in the index area indicated. The Pin 1 identifier may be either a mold, or an embedded metal or marked feature.

Symbol	A	A1	A2	b	D	D1	E	E1	e	
Dimension (inches)	MIN	.165	.090	.062	.013	.485	.450	.485	.450	.050 BSC
	NOM	.172	.105	-	-	.490	.453	.490	.453	
	MAX	.180	.120	.083	.021	.495	.456	.495	.456	

JEDEC Registration MS-018, Variation AB, Issue A, June, 1993.

Drawings not to scale.

48-Lead LQFP/TQFP (1.4mm) Package Outline (FG)

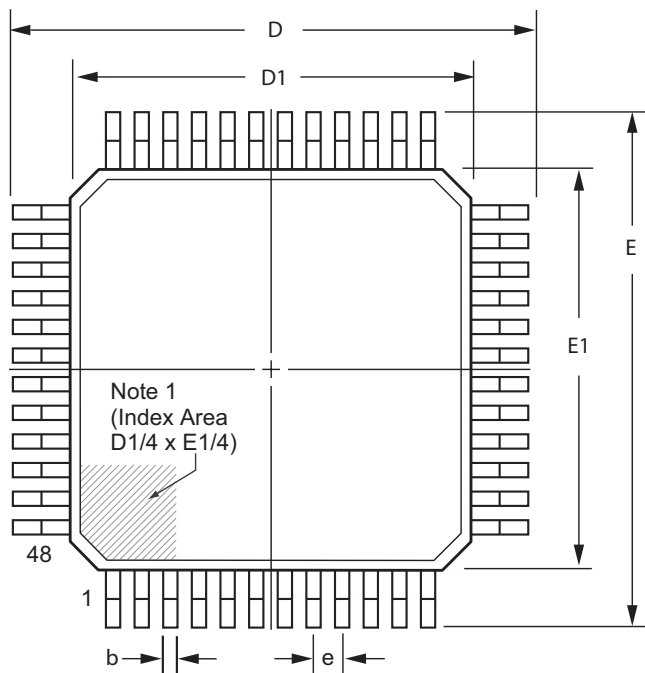

Top View

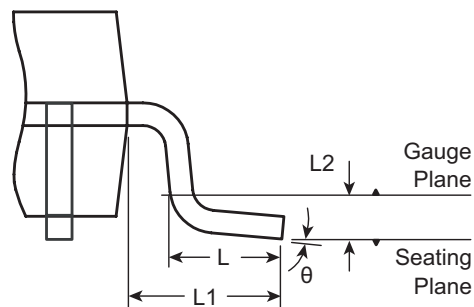

View B

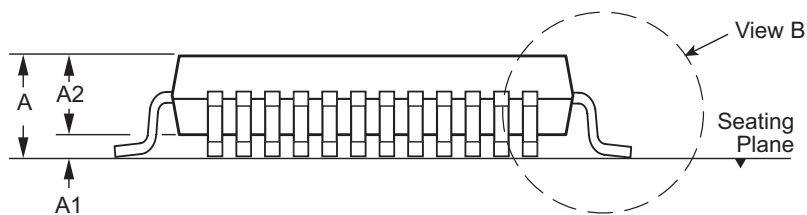

Side View

Note 1:

A Pin 1 identifier must be located in the index area indicated. The Pin 1 identifier may be either a mold, or an embedded metal or marked feature.

Symbol	A	A1	A2	b	D	D1	E	E1	e	L	L1	L2	θ	
Dimension (mm)	MIN	1.40	0.05	1.35	0.17	9.00 BSC	7.00 BSC	9.00 BSC	7.00 BSC	0.50 BSC	1.00 REF	0.25 BSC	0°	
	NOM	-	-	1.40	0.22								0.60	3.5°
	MAX	1.60	0.15	1.45	0.27								0.75	7°

JEDEC Registration MS-026, Variation BBC, Issue D, Jan. 2001.

Drawings not to scale.

(The package drawing(s) in this data sheet may not reflect the most current specifications. For the latest package outline information go to <http://www.supertex.com/packaging.html>.)

Supertex inc. does not recommend the use of its products in life support applications, and will not knowingly sell its products for use in such applications, unless it receives an adequate "product liability indemnification insurance agreement". **Supertex** does not assume responsibility for use of devices described and limits its liability to the replacement of the devices determined defective due to workmanship. No responsibility is assumed for possible omissions or inaccuracies. Circuitry and specifications are subject to change without notice. For the latest product specifications, refer to the **Supertex** website: <http://www.supertex.com>.