

DAC1005D650

Dual 10-bit DAC, up to 650 Msps; 2× 4× and 8× interpolating

Rev. 01 — 28 July 2009

Product data sheet

1. General description

The DAC1005D650 is a high-speed 10-bit dual-channel Digital-to-Analog Converter (DAC) with selectable 2×, 4× or 8× interpolating filters optimized for multi-carrier wireless transmitters.

Thanks to its digital on-chip modulation, the DAC1005D650 allows the complex I and Q inputs to be converted up from BaseBand (BB) to IF. The mixing frequency is adjusted using a Serial Peripheral Interface (SPI) with a 32-bit Numerically Controlled Oscillator (NCO). The phase is controlled by a 16-bit register.

Two modes of operation are available: separate data ports or a single interleaved high-speed data port. In the Interleaved mode, the input data stream is demultiplexed into its original I and Q data and then latched.

The DAC1005D650 also includes a 2×, 4× and 8× clock multiplier which provides the appropriate internal clocks and an internal regulator to adjust the output full-scale current.

2. Features

- Dual 10-bit resolution
- 650 Msps maximum update rate
- Selectable 2×, 4× or 8× interpolation filters
- Input data rate up to 160 Msps
- Very low noise cap-free integrated PLL
- 32-bit programmable NCO frequency
- Dual-port or Interleaved data modes
- 1.8 V and 3.3 V power supplies
- LVDS compatible clock
- Two's complement or binary offset data format
- 3.3 V CMOS input buffers
- IMD3: 79 dBc; $f_s = 640$ Msps; $f_o = 96$ MHz
- SFDR: 75 dBc; $f_{data} = 80$ MHz; $f_s = 640$ Msps; $f_o = 19$ MHz; PLL on
- Typical 0.95 W power dissipation at 4× interpolation
- Power-down and Sleep modes
- Differential scalable output current from 1.6 mA to 20 mA
- On-chip 1.25 V reference
- External analog offset control (10-bit auxiliary DACs)
- Internal digital offset control
- Inverse (sin x) / x function
- Fully compatible SPI port
- Industrial temperature range from -40 °C to $+85$ °C

3. Applications

- Wireless infrastructure: LTE, WiMAX, GSM, CDMA, WCDMA, TD-SCDMA
- Communication: LMDS/MMDS, point-to-point
- Direct Digital Synthesis (DDS)
- Broadband wireless systems
- Digital radio links
- Instrumentation
- Automated Test Equipment (ATE)

4. Ordering information

Table 1. Ordering information

Type number	Package		
	Name	Description	Version
DAC1005D650HW/C1	HTQFP100	plastic thermal enhanced thin quad flat package; 100 leads; body 14 × 14 × 1 mm; exposed die pad	SOT638-1

5. Block diagram

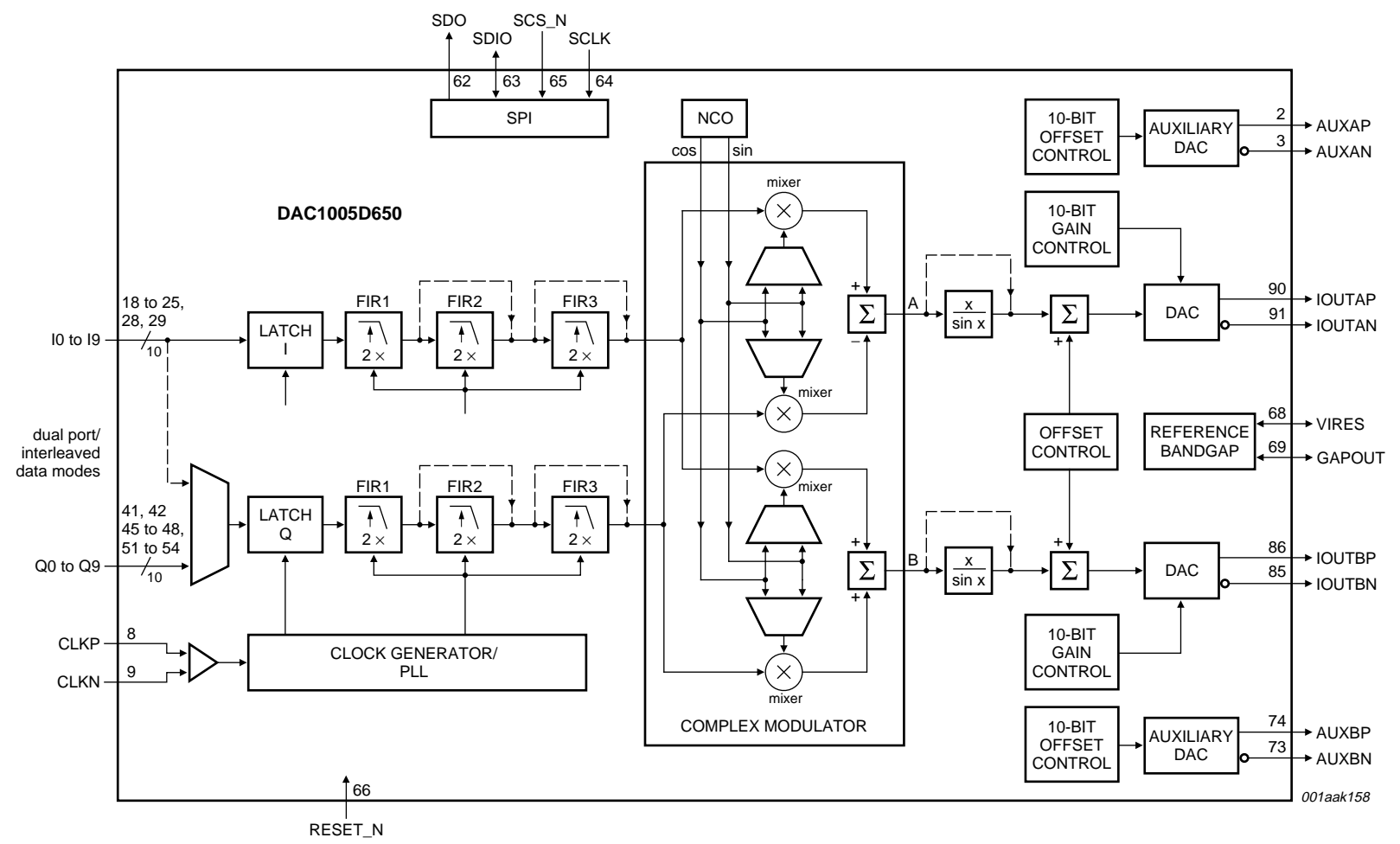
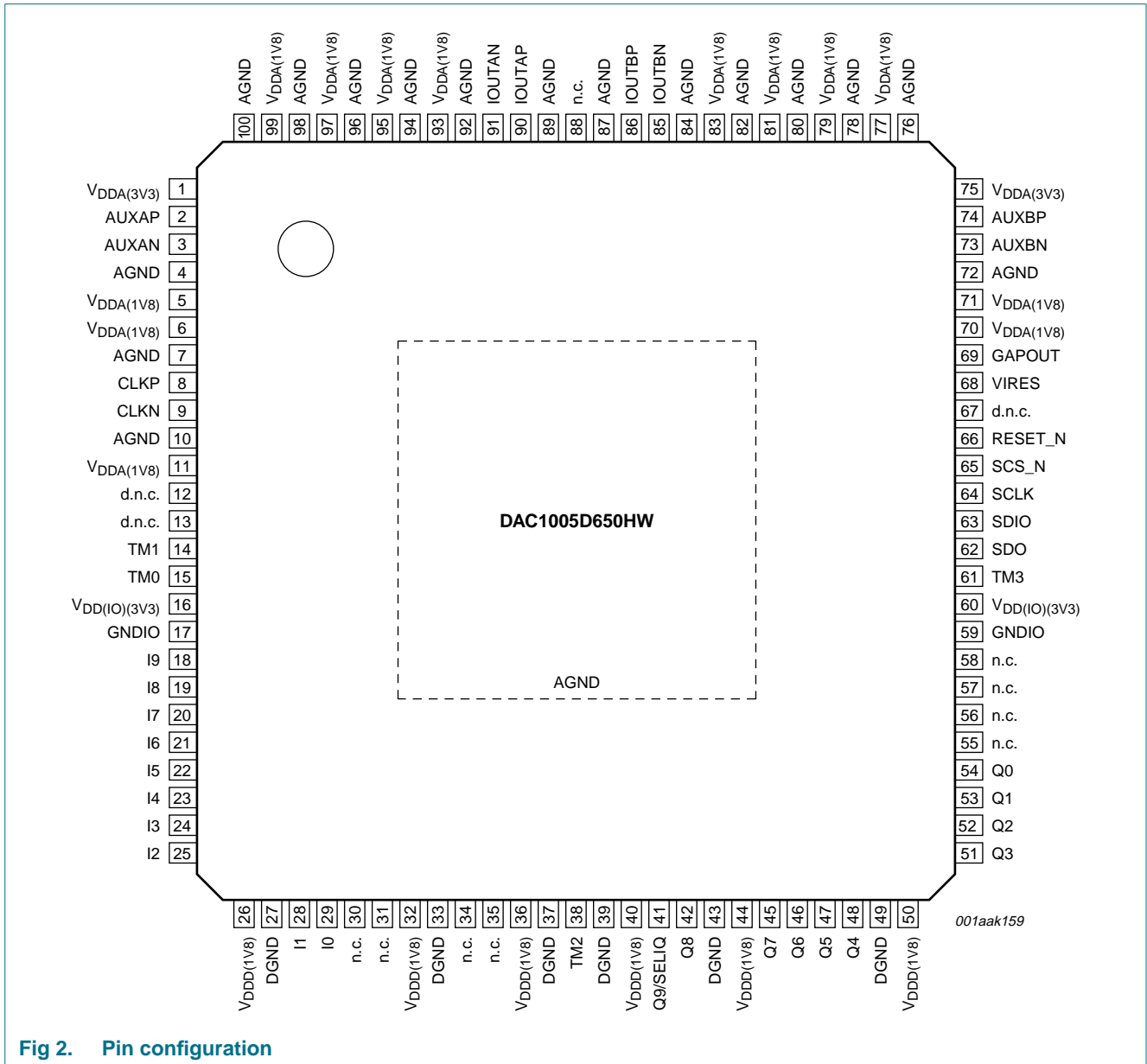

Fig 1. Block diagram

6. Pinning information

6.1 Pinning



6.2 Pin description

Table 2. Pin description

Symbol	Pin	Type ^[1]	Description
V _{DDA(3V3)}	1	P	analog supply voltage 3.3 V
AUXAP	2	O	auxiliary DAC B output current
AUXAN	3	O	complementary auxiliary DAC B output current
AGND	4	G	analog ground
V _{DDA(1V8)}	5	P	analog supply voltage 1.8 V
V _{DDA(1V8)}	6	P	analog supply voltage 1.8 V
AGND	7	G	analog ground
CLKP	8	I	clock input
CLKN	9	I	complementary clock input
AGND	10	G	analog ground
V _{DDA(1V8)}	11	P	analog supply voltage 1.8 V
d.n.c.	12	-	do not connect
d.n.c.	13	-	do not connect
TM1	14	I/O	test mode 1 (to connect to DGND)
TM0	15	I/O	test mode 0 (to connect to DGND)
V _{DD(IO)(3V3)}	16	P	input/output buffers supply voltage 3.3 V
GNDIO	17	G	input/output buffers ground
I9	18	I	I data input bit 9 (MSB)
I8	19	I	I data input bit 8
I7	20	I	I data input bit 7
I6	21	I	I data input bit 6
I5	22	I	I data input bit 5
I4	23	I	I data input bit 4
I3	24	I	I data input bit 3
I2	25	I	I data input bit 2
V _{DDD(1V8)}	26	P	digital supply voltage 1.8 V
DGND	27	G	digital ground
I1	28	I	I data input bit 1
I0	29	I	I data input bit 0 (LSB)
n.c.	30	I	not connected
n.c.	31	I	not connected
V _{DDD(1V8)}	32	P	digital supply voltage 1.8 V
DGND	33	G	digital ground
n.c.	34	I	not connected
n.c.	35	I	not connected
V _{DDD(1V8)}	36	P	digital supply voltage 1.8 V
DGND	37	G	digital ground
TM2	38	-	test mode 2 (to connect to DGND)
DGND	39	G	digital ground

Table 2. Pin description ...continued

Symbol	Pin	Type ^[1]	Description
V _{DD(1V8)}	40	P	digital supply voltage 1.8 V
Q9/SELIQ	41	I	Q data input bit 9 (MSB) select IQ
Q8	42	I	Q data input bit 8
DGND	43	G	digital ground
V _{DD(1V8)}	44	P	digital supply voltage 1.8 V
Q7	45	I	Q data input bit 7
Q6	46	I	Q data input bit 6
Q5	47	I	Q data input bit 5
Q4	48	I	Q data input bit 4
DGND	49	G	digital ground
V _{DD(1V8)}	50	P	digital supply voltage 1.8 V
Q3	51	I	Q data input bit 3
Q2	52	I	Q data input bit 2
Q1	53	I	Q data input bit 1
Q0	54	I	Q data input bit 0 (LSB)
n.c.	55	I	not connected
n.c.	56	I	not connected
n.c.	57	I	not connected
n.c.	58	I	not connected
GNDIO	59	G	input/output buffers ground
V _{DD(IO)(3V3)}	60	P	input/output buffers supply voltage 3.3 V
TM3	61	I/O	test mode 3 (to connect to DGND)
SDO	62	O	SPI data output
SDIO	63	I/O	SPI data input/output
SCLK	64	I	SPI clock
SCS_N	65	I	SPI chip select (active LOW)
RESET_N	66	I	general reset (active LOW)
d.n.c.	67	-	do not connect
VIRES	68	I/O	DAC biasing resistor
GAPOUT	69	I/O	bandgap input/output voltage
V _{D(1V8)}	70	P	analog supply voltage 1.8 V
V _{D(1V8)}	71	P	analog supply voltage 1.8 V
AGND	72	G	analog ground
AUXBN	73	O	complementary auxiliary DAC B output current
AUXBP	74	O	auxiliary DAC B output current
V _{D(3V3)}	75	P	analog supply voltage 3.3 V
AGND	76	G	analog ground
V _{D(1V8)}	77	P	analog supply voltage 1.8 V
AGND	78	G	analog ground
V _{D(1V8)}	79	P	analog supply voltage 1.8 V

Table 2. Pin description ...continued

Symbol	Pin	Type ^[1]	Description
AGND	80	G	analog ground
V _{DDA(1V8)}	81	P	analog supply voltage 1.8 V
AGND	82	G	analog ground
V _{DDA(1V8)}	83	P	analog supply voltage 1.8 V
AGND	84	G	analog ground
IOUTBN	85	O	complementary DAC B output current
IOUTBP	86	O	DAC B output current
AGND	87	G	analog ground
n.c.	88	-	not connected
AGND	89	G	analog ground
IOUTAP	90	O	DAC A output current
IOUTAN	91	O	complementary DAC A output current
AGND	92	G	analog ground
V _{DDA(1V8)}	93	P	analog supply voltage 1.8 V
AGND	94	G	analog ground
V _{DDA(1V8)}	95	P	analog supply voltage 1.8 V
AGND	96	G	analog ground
V _{DDA(1V8)}	97	P	analog supply voltage 1.8 V
AGND	98	G	analog ground
V _{DDA(1V8)}	99	P	analog supply voltage 1.8 V
AGND	100	G	analog ground
AGND	H ^[2]	G	analog ground

- [1] P = power supply
 G = ground
 I = input
 O = output.

- [2] H = heatsink (exposed die pad to be soldered).

7. Limiting values

Table 3. Limiting values

In accordance with the Absolute Maximum Rating System (IEC 60134).

Symbol	Parameter	Conditions	Min	Max	Unit
$V_{DD(I0)(3V3)}$	input/output supply voltage (3.3 V)		-0.5	+4.6	V
$V_{DDA(3V3)}$	analog supply voltage (3.3 V)		-0.5	+4.6	V
$V_{DDA(1V8)}$	analog supply voltage (1.8 V)		-0.5	+3.0	V
$V_{DDD(1V8)}$	digital supply voltage (1.8 V)		-0.5	+3.0	V
V_I	input voltage	pins CLKP, CLKN, VIRES and GAPOUT referenced to AGND	-0.5	+3.0	V
		pins I9 to I0, Q9 to Q0, SDO, SDIO, SCLK, SCS_N and RESET_N referenced to GNDIO	-0.5	+4.6	V
V_O	output voltage	pins IOUTAP, IOUTAN, IOUTBP, IOUTBN, AUXAP, AUXAN, AUXBP and AUXBN referenced to AGND	-0.5	+4.6	V
T_{stg}	storage temperature		-55	+150	°C
T_{amb}	ambient temperature		-45	+85	°C
T_j	junction temperature		-	125	°C

8. Thermal characteristics

Table 4. Thermal characteristics

Symbol	Parameter	Conditions	Typ	Unit
$R_{th(j-a)}$	thermal resistance from junction to ambient		[1] 19.8	K/W
$R_{th(j-c)}$	thermal resistance from junction to case		[1] 7.7	K/W

[1] In compliance with JEDEC test board, in free air.

9. Characteristics

Table 5. Characteristics

$V_{DDA(1V8)} = V_{DDD(1V8)} = 1.8\text{ V}$; $V_{DDA(3V3)} = V_{DD(IO)(3V3)} = 3.3\text{ V}$; AGND, DGND and GNDIO shorted together; $T_{amb} = -40\text{ °C}$ to $+85\text{ °C}$; typical values measured at $T_{amb} = 25\text{ °C}$; $R_L = 50\text{ }\Omega$; $I_{O(fs)} = 20\text{ mA}$; maximum sample rate; PLL on; unless otherwise specified.

Symbol	Parameter	Conditions	Test ^[1]	Min	Typ	Max	Unit
$V_{DD(IO)(3V3)}$	input/output supply voltage (3.3 V)		I	3.0	3.3	3.6	V
$V_{DDA(3V3)}$	analog supply voltage (3.3 V)		I	3.0	3.3	3.6	V
$V_{DDA(1V8)}$	analog supply voltage (1.8 V)		I	1.7	1.8	1.9	V
$V_{DDD(1V8)}$	digital supply voltage (1.8 V)		I	1.7	1.8	1.9	V
$I_{DD(IO)(3V3)}$	input/output supply current (3.3 V)	$f_o = 19\text{ MHz}$; $f_s = 640\text{ Msps}$; 8× interpolation; NCO on	I	-	5	13	mA
$I_{DDA(3V3)}$	analog supply current (3.3 V)	$f_o = 19\text{ MHz}$; $f_s = 640\text{ Msps}$; 8× interpolation; NCO on	I	-	48	26	mA
$I_{DDD(1V8)}$	digital supply current (1.8 V)	$f_o = 19\text{ MHz}$; $f_s = 640\text{ Msps}$; 8× interpolation; NCO on	I	-	270	309	mA
$I_{DDA(1V8)}$	analog supply current (1.8 V)	$f_o = 19\text{ MHz}$; $f_s = 640\text{ Msps}$; 8× interpolation; NCO on	I	-	330	358	mA
I_{DDD}	digital supply current	for x / (sin x) function only	I	-	67	-	mA
P_{tot}	total power dissipation	$f_o = 19\text{ MHz}$; $f_s = 320\text{ Msps}$; 4× interpolation; NCO off; DAC B off	C	-	0.53	-	W
		$f_o = 19\text{ MHz}$; $f_s = 320\text{ Msps}$; 4× interpolation; NCO off	C	-	0.82	-	W
		$f_o = 19\text{ MHz}$; $f_s = 320\text{ Msps}$; 4× interpolation; NCO on	C	-	0.94	-	W
		$f_o = 19\text{ MHz}$; $f_s = 640\text{ Msps}$; 8× interpolation; NCO off	C	-	0.95	-	W
		$f_o = 19\text{ MHz}$; $f_s = 640\text{ Msps}$; 8× interpolation; NCO on; all V_{DD}	I	-	1.18	1.4	W
		$f_o = 19\text{ MHz}$; $f_s = 640\text{ Msps}$; 8× interpolation; NCO low power on	C	-	1.07	-	W
		Power-down mode					
		full power-down; all V_{DD}	I	-	0.08	0.13	W
		DAC A and DAC B Sleep mode; 8× interpolation; NCO on	I	-	0.88	-	W

Table 5. Characteristics ...continued

$V_{DDA(1V8)} = V_{DDD(1V8)} = 1.8\text{ V}$; $V_{DDA(3V3)} = V_{DD(I/O)(3V3)} = 3.3\text{ V}$; AGND, DGND and GNDIO shorted together; $T_{amb} = -40\text{ °C to }+85\text{ °C}$; typical values measured at $T_{amb} = 25\text{ °C}$; $R_L = 50\text{ }\Omega$; $I_{O(fs)} = 20\text{ mA}$; maximum sample rate; PLL on; unless otherwise specified.

Symbol	Parameter	Conditions	Test ^[1]	Min	Typ	Max	Unit
Clock inputs (CLKP and CLKN)^[2]							
V_i	input voltage	CLKP; or CLKN $ V_{gpd} < 50\text{ mV}$	C	^[3] 825	-	1575	mV
V_{idth}	input differential threshold voltage	$ V_{gpd} < 50\text{ mV}$	C	^[3] -100	-	+100	mV
R_i	input resistance		D	-	10	-	M Ω
C_i	input capacitance		D	-	0.5	-	pF
Digital inputs (I0 to I13, Q0 to Q13)							
V_{IL}	LOW-level input voltage		C	GNDIO	-	1.0	V
V_{IH}	HIGH-level input voltage		C	2.3	-	$V_{DD(I/O)(3V3)}$	V
I_{IL}	LOW-level input current	$V_{IL} = 1.0\text{ V}$	I	-	40	-	μA
I_{IH}	HIGH-level input current	$V_{IH} = 2.3\text{ V}$	I	-	80	-	μA
Digital inputs (SDO, SDIO, SCLK, SCS_N and RESET_N)							
V_{IL}	LOW-level input voltage		C	GNDIO	-	1.0	V
V_{IH}	HIGH-level input voltage		C	2.3	-	$V_{DD(I/O)(3V3)}$	V
I_{IL}	LOW-level input current	$V_{IL} = 1.0\text{ V}$	I	-	20	-	nA
I_{IH}	HIGH-level input current	$V_{IH} = 2.3\text{ V}$	I	-	20	-	nA
Analog outputs (IOUTAP, IOUTAN, IOUTBP and IOUTBN)							
$I_{O(fs)}$	full-scale output current	register value = 00h	C	-	1.6	-	mA
		default register	C	-	20	-	mA
V_O	output voltage	compliance range	C	1.8	-	$V_{DDA(3V3)}$	V
R_o	output resistance		D	-	250	-	k Ω
C_o	output capacitance		D	-	3	-	pF
$N_{DAC(\text{mono})}$	DAC monotonicity	guaranteed	D	-	8	-	bit
ΔE_O	offset error variation		C	-	6	-	ppm/ $^{\circ}\text{C}$
ΔE_G	gain error variation		C	-	18	-	ppm/ $^{\circ}\text{C}$
Reference voltage output (GAPOUT)							
$V_{O(\text{ref})}$	reference output voltage	$T_{amb} = 25\text{ }^{\circ}\text{C}$	I	1.2	1.25	1.29	V
$\Delta V_{O(\text{ref})}$	reference output voltage variation		C	-	117	-	ppm/ $^{\circ}\text{C}$
$I_{O(\text{ref})}$	reference output current	external voltage 1.25 V	D	-	40	-	μA

Table 5. Characteristics ...continued

$V_{DDA(1V8)} = V_{DDD(1V8)} = 1.8\text{ V}$; $V_{DDA(3V3)} = V_{DD(I/O)(3V3)} = 3.3\text{ V}$; AGND, DGND and GNDIO shorted together;
 $T_{amb} = -40\text{ °C}$ to $+85\text{ °C}$; typical values measured at $T_{amb} = 25\text{ °C}$; $R_L = 50\ \Omega$; $I_{O(fs)} = 20\text{ mA}$; maximum sample rate; PLL on;
 unless otherwise specified.

Symbol	Parameter	Conditions	Test ^[1]	Min	Typ	Max	Unit
Analog auxiliary outputs (AUXAP, AUXAN, AUXBP and AUXBN)							
$I_{O(aux)}$	auxiliary output current	differential outputs	I	-	2.2	-	mA
$V_{O(aux)}$	auxiliary output voltage	compliance range	C	0	-	2	V
$N_{DAC(aux)mono}$	auxiliary DAC monotonicity	guaranteed	D	-	10	-	bit
Input timing (see Figure 10)							
f_{data}	data rate	Dual-port mode input	C	-	-	160	MHz
$t_{w(CLK)}$	CLK pulse width		C	1.5	-	$T_{data} - 1.5$	ns
$t_{h(i)}$	input hold time		C	1.1	-	-	ns
$t_{su(i)}$	input set-up time		C	1.1	-	-	ns
Output timing							
f_s	sampling frequency		C	-	-	650	Msps
t_s	settling time	to ± 0.5 LSB	D	-	20	-	ns
NCO frequency range; $f_s = 640$ Msps							
f_{NCO}	NCO frequency	register value = 00000000h	D	-	0	-	MHz
		register value = FFFFFFFFh	D	-	640	-	MHz
f_{step}	step frequency		D	-	0.149	-	Hz
Low-power NCO frequency range; $f_{DAC} = 640$ MHz							
f_{NCO}	NCO frequency	register value = 00000000h	D	-	0	-	MHz
		register value = F8000000h	D	-	620	-	MHz
f_{step}	step frequency		D	-	20	-	MHz
Dynamic performance; PLL on							
SFDR	spurious-free dynamic range	$f_{data} = 80\text{ MHz}$; $f_s = 320\text{ Msps}$; $B = f_{data} / 2$	C	-	82	-	dBc
		$f_{data} = 80\text{ MHz}$; $f_s = 640\text{ Msps}$; $B = f_{data} / 2$	I	-	76	-	dBc
			I	-	75	-	dBc
			$f_o = 19\text{ MHz}$ at 0 dBFS				
		$f_{data} = 160\text{ MHz}$; $f_s = 640\text{ Msps}$; $B = f_{data} / 2$	C	-	82	-	dBc
$f_o = 70\text{ MHz}$ at 0 dBFS							

Table 5. Characteristics ...continued

$V_{DDA(1V8)} = V_{DDD(1V8)} = 1.8\text{ V}$; $V_{DDA(3V3)} = V_{DD(I/O)(3V3)} = 3.3\text{ V}$; AGND, DGND and GNDIO shorted together; $T_{amb} = -40\text{ °C to }+85\text{ °C}$; typical values measured at $T_{amb} = 25\text{ °C}$; $R_L = 50\ \Omega$; $I_{O(fs)} = 20\text{ mA}$; maximum sample rate; PLL on; unless otherwise specified.

Symbol	Parameter	Conditions	Test ^[1]	Min	Typ	Max	Unit	
SFDR _{RBW}	restricted bandwidth spurious-free dynamic range	$f_s = 640\text{ Msps}$; $f_o = 96\text{ MHz}$ at 0 dBFS						
		$2.51\text{ MHz} \leq f_{\text{offset}} \leq 2.71\text{ MHz}$; B = 30 kHz	I	-	-89	-83	dBc	
		$2.71\text{ MHz} \leq f_{\text{offset}} \leq 3.51\text{ MHz}$; B = 30 kHz	I	-	-88	-	dBc	
		$3.51\text{ MHz} \leq f_{\text{offset}} \leq 4\text{ MHz}$; B = 30 kHz	I	-	-89	-81	dBc	
		$4\text{ MHz} \leq f_{\text{offset}} \leq 40\text{ MHz}$; B = 1 MHz	I	-	-83	-67	dBc	
IMD3	third-order intermodulation distortion	$f_s = 320\text{ Msps}$; 4× interpolation						
		$f_{o1} = 49\text{ MHz}$; $f_{o2} = 51\text{ MHz}$	C	[4]	-	81	-	dBc
		$f_{o1} = 95\text{ MHz}$; $f_{o2} = 97\text{ MHz}$	C	[4]	-	80	-	dBc
		$f_s = 640\text{ Msps}$; 8× interpolation						
		$f_{o1} = 95\text{ MHz}$; $f_{o2} = 97\text{ MHz}$	I	[4]	67	79	-	dBc
		$f_{o1} = 152\text{ MHz}$; $f_{o2} = 154\text{ MHz}$	C	[4]	-	77	-	dBc
ACPR	adjacent channel power ratio	$f_{\text{data}} = 76.8\text{ MHz}$; $f_s = 614.4\text{ Msps}$; $f_o = 96\text{ MHz}$						
		1 carrier; B = 5 MHz	I	-	64	-	dB	
		2 carriers; B = 10 MHz	C	-	61	-	dB	
		4 carriers; B = 20 MHz	C	-	60	-	dB	
		$f_{\text{data}} = 153.6\text{ MHz}$; $f_s = 614.4\text{ Msps}$; $f_o = 115.2\text{ MHz}$						
		1 carrier; B = 5 MHz	C	-	67	-	dB	
		2 carriers; B = 10 MHz	C	-	63	-	dB	
		4 carriers; B = 20 MHz	C	-	60	-	dB	
		$f_{\text{data}} = 153.6\text{ MHz}$; $f_s = 614.4\text{ Msps}$; $f_o = 153.6\text{ MHz}$						
		1 carrier; B = 5 MHz	C	-	65	-	dB	
		2 carriers; B = 10 MHz	C	-	63	-	dB	
		4 carriers; B = 20 MHz	C	-	60	-	dB	
		NSD	noise spectral density	$f_s = 640\text{ Msps}$; 8× interpolation; $f_o = 19\text{ MHz}$ at 0 dBFS				
noise shaper disabled	C			-	-138	-	dBm/Hz	
noise shaper enabled	C			-	-139	-	dBm/Hz	

- [1] D = guaranteed by design; C = guaranteed by characterization; I = 100 % industrially tested.
- [2] CLKP and CLKN inputs are at differential LVDS levels. An external differential resistor with a value of between 80 Ω and 120 Ω should be connected across the pins (see Figure 8).
- [3] $|V_{\text{gpd}}|$ represents the ground potential difference voltage. This is the voltage that results from current flowing through the finite resistance and the inductance between the receiver and the driver circuit ground.
- [4] IMD3 rejection with -6 dBFS/tone.

10. Application information

10.1 General description

The DAC1005D650 is a dual 10-bit DAC operating at up to 650 Msps. Each DAC consists of a segmented architecture, comprising a 6-bit thermometer sub-DAC and an 4-bit binary weighted sub-DAC.

With an input data rate of up to 160 MHz, and a maximum output sampling rate of 650 Msps, the DAC1005D650 allows more flexibility for wide bandwidth and multi-carrier systems. Combined with its quadrature modulator and its 32-bit NCO, the DAC1005D650 simplifies the frequency selection of the system. This is also possible because of the 2×, 4× and 8× interpolation filters that remove undesired images.

Two modes are available for the digital input. In the Dual-port mode, each DAC uses its own data input line. In Interleaved mode, both DACs use the same data input line.

Each DAC generates two complementary current outputs on pins IOUTAP/IOUTAN and IOUTBP/IOUTBN. This provides a full-scale output current ($I_{O(fs)}$) up to 20 mA. An internal reference is available for the reference current which is externally adjustable using pin VIRES.

There are embedded features which provide analog offset correction (internal auxiliary DACs), digital offset control and gain adjustment. All the functions can be set using a SPI.

The DAC1005D650 operates at both 3.3 V and 1.8 V using separate digital and analog power supplies. The digital input is 3.3 V compliant and the clock input is LVDS compliant.

10.2 Serial interface (SPI)

10.2.1 Protocol description

The DAC1005D650 serial interface is a synchronous serial communication port allowing easy interfacing with many industry microprocessors. It provides access to the registers that define the operating modes of the chip in both write and read modes.

This interface can be configured as a 3-wire type (SDIO as bidirectional pin) or a 4-wire type (SDIO and SDO as unidirectional pin, input and output port respectively). In both configurations, SCLK acts as the serial clock, and SCS_N acts as the serial chip select bar.

Each read/write operation is sequenced by the SCS_N signal and enabled by a LOW assertion to drive the chip with between 2 to 5 bytes, depending on the content of the instruction byte (see [Table 7](#)).

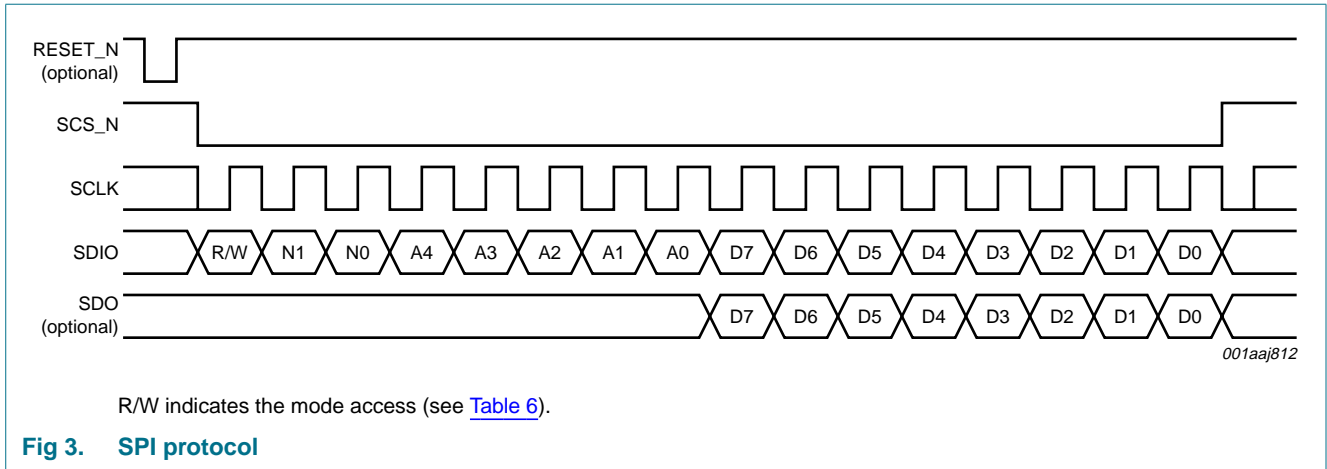

Fig 3. SPI protocol

Table 6. Read or Write mode access description

R/W	Description
0	Write mode operation
1	Read mode operation

In [Table 7](#) N1 and N0 indicate the number of bytes transferred after the instruction byte.

Table 7. Number of bytes to be transferred

N1	N0	Number of bytes
0	0	1 byte transferred
0	1	2 bytes transferred
1	0	3 bytes transferred
1	1	4 bytes transferred

A0 to A4 indicates which register is being addressed. In the case of a multiple transfer, this address concerns the first register after which the next registers follow directly in decreasing order according to [Table 9 "Register allocation map"](#).

10.2.2 SPI timing description

SPI can operate at a frequency of up to 15 MHz. The SPI timing is shown in [Figure 4](#).

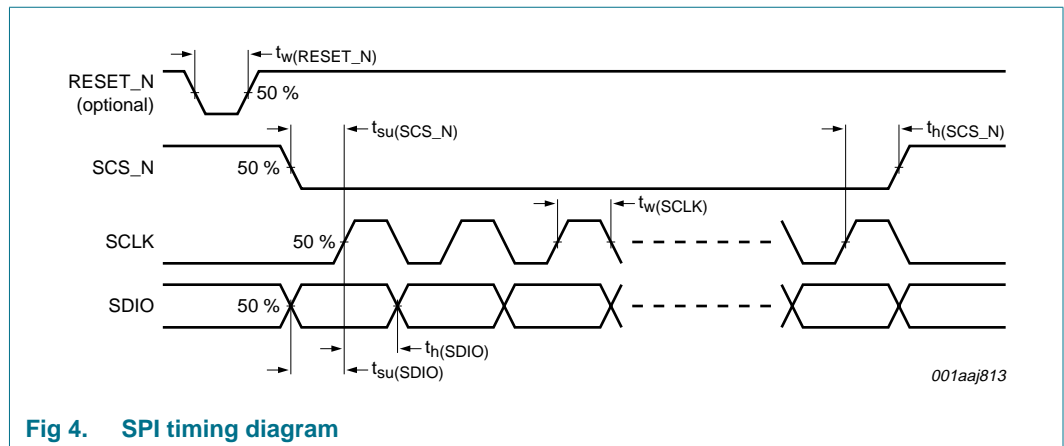

Fig 4. SPI timing diagram

The SPI timing characteristics are given in [Table 8](#).

Table 8. SPI timing characteristics

Symbol	Parameter	Min	Typ	Max	Unit
f_{SCLK}	SCLK frequency	-	-	15	MHz
$t_{\text{w(SCLK)}}$	SCLK pulse width	30	-	-	ns
$t_{\text{su(SCS_N)}}$	SCS_N set-up time	20	-	-	ns
$t_{\text{h(SCS_N)}}$	SCS_N hold time	20	-	-	ns
$t_{\text{su(SDIO)}}$	SDIO set-up time	10	-	-	ns
$t_{\text{h(SDIO)}}$	SDIO hold time	5	-	-	ns
$t_{\text{w(RESET_N)}}$	RESET_N pulse width	30	-	-	ns

10.2.3 Detailed descriptions of registers

An overview of the details for all registers is provided in [Table 9](#).

Table 9. Register allocation map

Address	Register name	R/W	Bit definition									Default		
			b7	b6	b5	b4	b3	b2	b1	b0	Bin	Hex	Dec	
0	00h	COMMon	R/W	3W_SPI	SPI_RST	CLK_SEL	-	MODE_SEL	CODING	IC_PD	GAP_PD	10000000	80	128
1	01h	TXCFG	R/W	NCO_ON	NCO_LP_SEL	INV_SIN_SEL	MODULATION[2:0]			INTERPOLATION[1:0]		10000111	87	135
2	02h	PLLCFG	R/W	PLL_PD	-	PLL_DIV_PD	PLL_DIV[1:0]		PLL_PHASE[1:0]		PLL_POL	00010000	10	16
3	03h	FREQNCO_LSB	R/W	FREQ_NCO[7:0]								01100110	66	102
4	04h	FREQNCO_LISB	R/W	FREQ_NCO[15:8]								01100110	66	102
5	05h	FREQNCO_UISB	R/W	FREQ_NCO[23:16]								01100110	66	102
6	06h	FREQNCO_MSB	R/W	FREQ_NCO[31:24]								00100110	26	38
7	07h	PHINCO_LSB	R/W	PH_NCO[7:0]								00000000	00	0
8	08h	PHINCO_MSB	R/W	PH_NCO[15:8]								00000000	00	0
9	09h	DAC_A_Cfg_1	R/W	DAC_A_PD	DAC_A_SLEEP	DAC_A_OFFSET[2:0]		-	-	-	00000000	00	0	
10	0Ah	DAC_A_Cfg_2	R/W	DAC_A_GAIN_COARSE[1:0]		DAC_A_GAIN_FINE[5:0]					01000000	40	64	
11	0Bh	DAC_A_Cfg_3	R/W	DAC_A_GAIN_COARSE[3:2]		DAC_A_OFFSET[8:3]					11000000	C0	192	
12	0Ch	DAC_B_Cfg_1	R/W	DAC_B_PD	DAC_B_SLEEP	DAC_B_OFFSET[2:0]		-	-	-	00000000	00	0	
13	0Dh	DAC_B_Cfg_2	R/W	DAC_B_GAIN_COARSE[1:0]		DAC_B_GAIN_FINE[5:0]					01000000	40	64	
14	0Eh	DAC_B_Cfg_3	R/W	DAC_B_GAIN_COARSE[3:2]		DAC_B_OFFSET[8:3]					11000000	C0	192	
15	0Fh	DAC_Cfg	R/W	-	-	-	-	-	-	MINUS_3DB	NOISE_SHPER	00000000	00	0
...
26	1Ah	DAC_A_Aux_MSB	R/W	AUX_A[9:2]								10000000	80	128
27	1Bh	DAC_A_Aux_LSB	R/W	AUX_A_PD	-	-	-	-	-	AUX_A[1:0]		00000000	00	0
28	1Ch	DAC_B_Aux_MSB	R/W	AUX_B[9:2]								10000000	80	128
29	1Dh	DAC_B_Aux_LSB	R/W	AUX_B_PD	-	-	-	-	-	AUX_B[1:0]		00000000	00	0

10.2.4 Registers detailed description

Please refer to [Table 9](#) for a register overview and their default values. In the following tables, all default results are shown highlighted.

Table 10. COMMON register (address 00h) bit description

Default settings are shown highlighted.

Bit	Symbol	Access	Value	Description
7	3W_SPI	R/W		serial interface bus type
			0	4 wire SPI
			1	3 wire SPI
6	SPI_RST	R/W		serial interface reset
			0	no reset
			1	performs a reset on all registers except 00h
5	CLK_SEL	R/W		data input latch
			0	at CLK rising edge
			1	at CLK falling edge
3	MODE_SEL	R/W		input data mode
			0	dual-port
			1	interleaved
2	CODING	R/W		coding
			0	binary
			1	two's compliment
1	IC_PD	R/W		power-down
			0	disabled
			1	all circuits (digital and analog, except SPI) are switched off
0	GAP_PD	R/W		internal bandgap power-down
			0	power-down disabled
			1	internal bandgap references are switched off

Table 11. TXCFG register (address 01h) bit description

Default settings are shown highlighted.

Bit	Symbol	Access	Value	Description
7	NCO_ON	R/W		NCO
			0	disabled (the NCO phase is reset to 0°)
			1	enabled
6	NCO_LP_SEL	R/W		low-power NCO
			0	disabled
			1	NCO frequency and phase given by the five MSBs of the registers 06h and 08h respectively

Table 11. TXCFG register (address 01h) bit description ...continued

Default settings are shown highlighted.

Bit	Symbol	Access	Value	Description
4 to 2	MODULATION[2:0]	R/W		modulation
			000	dual DAC: no modulation
			001	positive upper single sideband up-conversion
			010	positive lower single sideband up-conversion
			011	negative upper single sideband up-conversion
			100	negative lower single sideband up-conversion
1 to 0	INTERPOLATION[1:0]	R/W		interpolation
			01	$f_s = 2f_{clk}$
			10	$f_s = 4f_{clk}$
			11	$f_s = 8f_{clk}$

Table 12. PLLCFG register (address 02h) bit description

Default settings are shown highlighted.

Bit	Symbol	Access	Value	Description
7	PLL_PD	R/W		PLL
			0	switched on
			1	switched off
5	PLL_DIV_PD	R/W		PLL divider
			0	switched on
			1	switched off
4 to 3	PLL_DIV[1:0]	R/W		PLL divider factor
			00	$f_s = 2 \times f_{clk}$
			01	$f_s = 4 \times f_{clk}$
			10	$f_s = 8 \times f_{clk}$
2 to 1	PLL_PHASE[1:0]	R/W		PLL phase shift of f_s
			00	0°
			01	120°
			10	240°
0	PLL_POL	R/W		DAC clock edge
			0	normal
			1	inverted

Table 13. FREQNCO_LSB register (address 03h) bit description

Bit	Symbol	Access	Value	Description
7 to 0	FREQ_NCO[7:0]	R/W	-	lower 8 bits for the NCO frequency setting

Table 14. FREQNCO_LISB register (address 04h) bit description

Bit	Symbol	Access	Value	Description
7 to 0	FREQ_NCO[15:8]	R/W	-	lower intermediate 8 bits for the NCO frequency setting

Table 15. FREQNCO_UI SB register (address 05h) bit description

Bit	Symbol	Access	Value	Description
7 to 0	FREQ_NCO[23:16]	R/W	-	upper intermediate 8 bits for the NCO frequency setting

Table 16. FREQNCO_MSB register (address 06h) bit description

Bit	Symbol	Access	Value	Description
7 to 0	FREQ_NCO[31:24]	R/W	-	most significant 8 bits for the NCO frequency setting

Table 17. PHINCO_LSB register (address 07h) bit description

Bit	Symbol	Access	Value	Description
7 to 0	PH_NCO[7:0]	R/W	-	lower 8 bits for the NCO phase setting

Table 18. PHINCO_MSB register (address 08h) bit description

Bit	Symbol	Access	Value	Description
7 to 0	PH_NCO[15:8]	R/W	-	most significant 8 bits for the NCO phase setting

Table 19. DAC_A_Cfg_1 register (address 09h) bit description

Default settings are shown highlighted.

Bit	Symbol	Access	Value	Description
7	DAC_A_PD	R/W		DAC A power
			0	on
6	DAC_A_SLEEP	R/W	1	off
			0	disabled
5 to 3	DAC_A_OFFSET[2:0]	R/W	1	enabled
			-	lower 3 bits for the DAC A offset

Table 20. DAC_A_Cfg_2 register (address 0Ah) bit description

Bit	Symbol	Access	Value	Description
7 to 6	DAC_A_GAIN_COARSE[1:0]	R/W	-	least significant 2 bits for the DAC A gain setting for coarse adjustment
5 to 0	DAC_A_GAIN_FINE[5:0]	R/W	-	the 6 bits for the DAC A fine adjustment gain setting

Table 21. DAC_A_Cfg_3 register (address 0Bh) bit description

Bit	Symbol	Access	Value	Description
7 to 6	DAC_A_GAIN_COARSE[3:2]	R/W	-	most significant 2 bits for the DAC A gain setting for coarse adjustment
5 to 0	DAC_A_OFFSET[8:3]	R/W	-	most significant 6 bits for the DAC A offset

Table 22. DAC_B_Cfg_1 register (address 0Ch) bit description

Default settings are shown highlighted.

Bit	Symbol	Access	Value	Description
7	DAC_B_PD	R/W		DAC B power
			0	on
			1	off
6	DAC_B_SLEEP	R/W		DAC B Sleep mode
			0	disabled
			1	enabled
5 to 3	DAC_B_OFFSET[2:0]	R/W		lower 3 bits for the DAC B offset

Table 23. DAC_B_Cfg_2 register (address 0Dh) bit description

Bit	Symbol	Access	Value	Description
7 to 6	DAC_B_GAIN_COARSE[1:0]	R/W	-	less significant 2 bits for the DAC B gain setting for coarse adjustment
5 to 0	DAC_B_GAIN_FINE[5:0]	R/W	-	the 6 bits for the DAC B gain setting for fine adjustment

Table 24. DAC_B_Cfg_3 register (address 0Eh) bit description

Bit	Symbol	Access	Value	Description
7 to 6	DAC_B_GAIN_COARSE[3:2]	R/W	-	most significant 2 bits for the DAC B gain setting for coarse adjustment
5 to 0	DAC_B_OFFSET[8:3]	R/W	-	most significant 6 bits for the DAC B offset

Table 25. DAC_Cfg register (address 0Fh) bit description

Default settings are shown highlighted.

Bit	Symbol	Access	Value	Description
1	MINUS_3DB	R/W		NCO gain
			0	unity
			1	-3 dB
0	NOISE_SHPER	R/W		noise shaper
			0	disabled
			1	enabled

Table 26. DAC_A_Aux_MSB register (address 1Ah) bit description

Bit	Symbol	Access	Value	Description
7 to 0	AUX_A[9:2]	R/W	-	most significant 8 bits for the auxiliary DAC A

Table 27. DAC_A_Aux_LSB register (address 1Bh) bit description

Default settings are shown highlighted.

Bit	Symbol	Access	Value	Description
7	AUX_A_PD	R/W		auxiliary DAC A power
			0	on
			1	off
1 to 0	AUX_A[1:0]	R/W		lower 2 bits for the auxiliary DAC A

Table 28. DAC_B_Aux_MSB register (address 1Ch) bit description

Bit	Symbol	Access	Value	Description
7 to 0	AUX_B[9:2]	R/W	-	most significant 8 bits for the auxiliary DAC B

Table 29. DAC_B_Aux_LSB register (address 1Dh) bit description

Default settings are shown highlighted.

Bit	Symbol	Access	Value	Description
7	AUX_B_PD	R/W	0	auxiliary DAC B power on
			1	off
1 to 0	AUX_B[1:0]	R/W		lower 2 bits for the auxiliary DAC B

10.3 Input data

The setting applied to MODE_SEL (register 00h[3]; see [Table 10 on page 17](#)) defines whether the DAC1005D650 operates in the Dual-port mode or in the Interleaved mode (see [Table 30](#)).

Table 30. Mode selection

Bit 3 setting	Function	I9 to I0	Q9 to Q0
0	Dual-port mode (pin Q9)	active	active
1	Interleaved mode (pin SELIQ)	active	off

10.3.1 Dual-port mode

The data input for Dual-port mode operation is shown in [Figure 5 “Dual-port mode”](#). Each DAC has its own independent data input. The data enters the input latch on the rising edge of the internal clock signal and is transferred to the DAC latch.

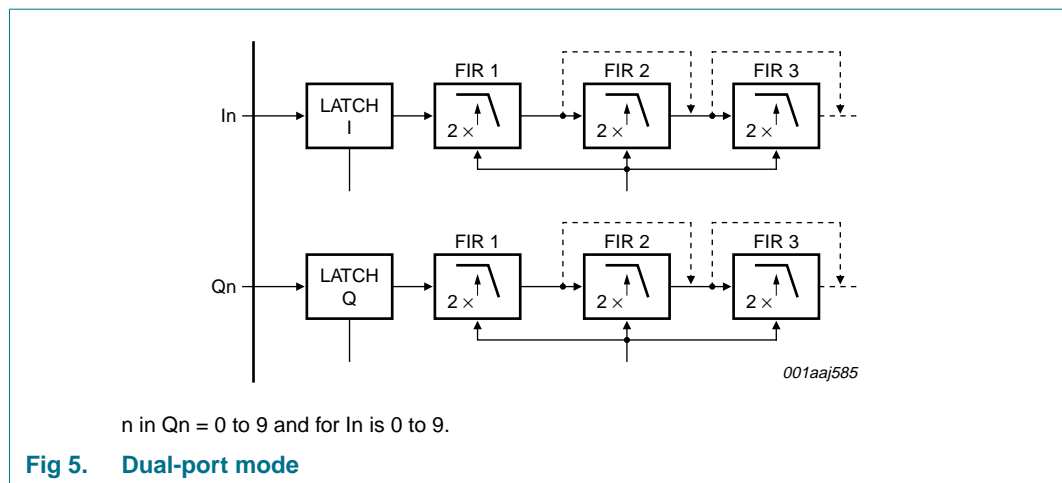

10.3.2 Interleaved mode

The data input for Interleaved mode operation is shown in [Figure 6 “Interleaved mode operation”](#).

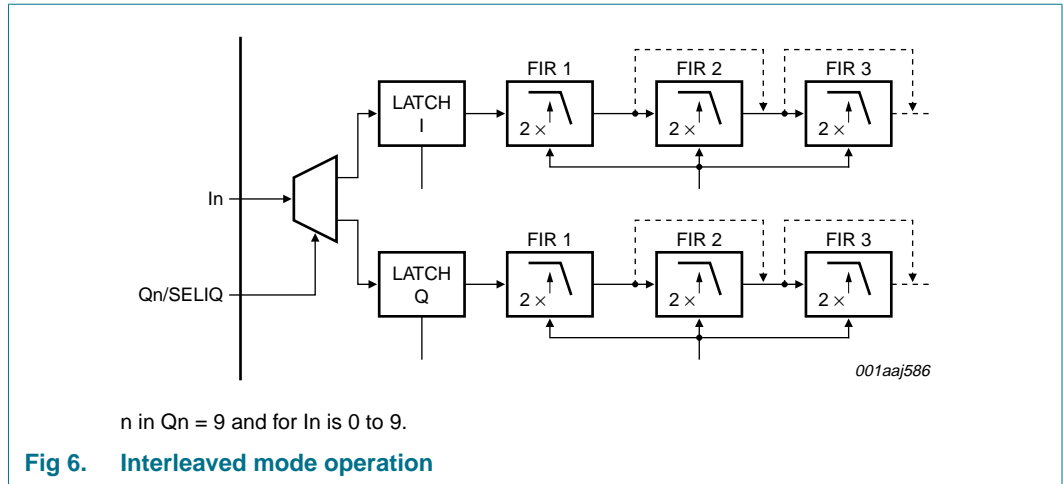

In the Interleaved mode, both DACs use the same data input at twice the Dual-port mode frequency. Data enters the latch on the rising edge of the internal clock signal. The data is sent to either latch I or latch Q, see [Figure 6 “Interleaved mode operation”](#) and [Figure 7 “Interleaved mode timing \(8x interpolation, latch on rising edge\)”](#).

The SELIQ input (pin 41) allows the synchronization of the internally de-multiplexed I and Q channels.

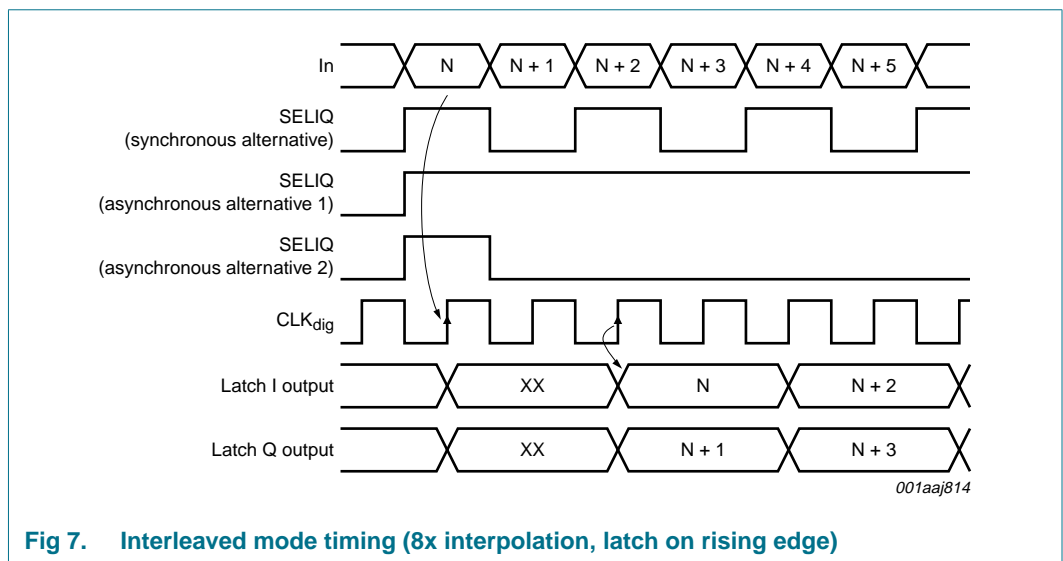

SELIQ can be either a synchronous or asynchronous (single rising edge, single pulse) signal. The first data bits following the SELIQ rising edge are sent in channel I and the following data bits are sent in channel Q. After this, the data is distributed alternately between both channels.

10.4 Input clock

The DAC1005D650 can operate with a clock frequency of 160 MHz in the Dual-port mode and up to 320 MHz in the Interleaved mode. The input clock is LVDS (see [Figure 8](#)) but it can also be interfaced with CML (see [Figure 9](#)).

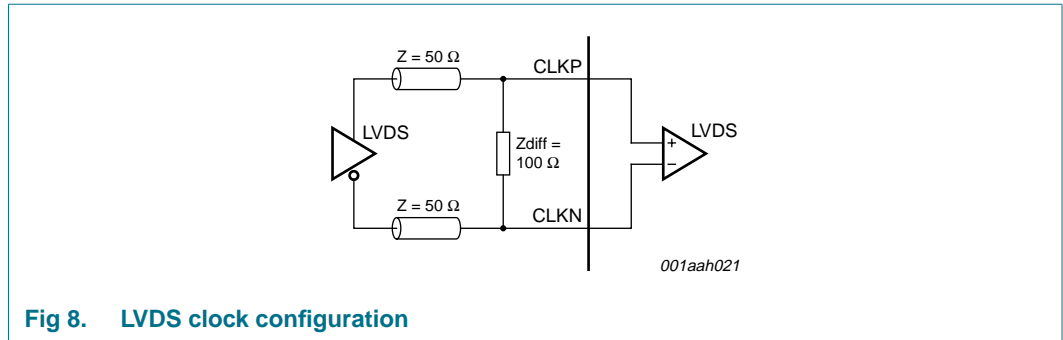

Fig 8. LVDS clock configuration

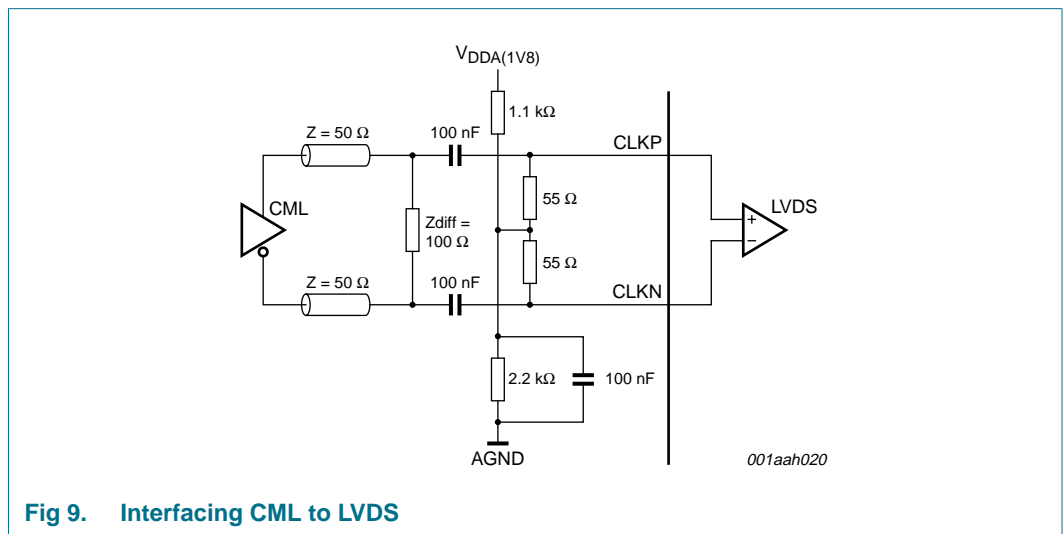

Fig 9. Interfacing CML to LVDS

10.5 Timing

The DAC1005D650 can operate at an update rate (f_s) of up to 650 Msps and with an input data rate (f_{data}) of up to 160 MHz. The input timing is shown in [Figure 10 “Input timing diagram”](#).

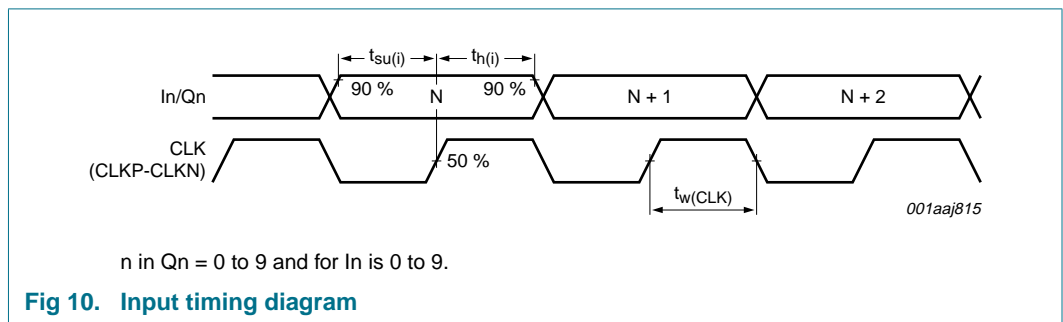

Fig 10. Input timing diagram

The typical performances are measured at 50 % duty cycle but any timing within the limits of the characteristics will not alter the performance.

In [Table 31 “Frequencies”](#), the links between internal and external clocking are defined. The setting applied to PLL_DIV[1:0] (register 02h[4:3]; see [Table 12 “PLLCFG register \(address 02h\) bit description”](#)) allows the frequency between the digital part and the DAC core to be adjusted.

Table 31. Frequencies

Mode	CLK input (MHz)	Input data rate (MHz)	Interpolation	Update rate (Msps)	PLL_DIV[1:0]
Dual-port	160	160	2×	320	01 (/4)
Dual-port	160	160	4×	640	01 (/4)
Dual-port	80	80	8×	640	10 (/8)
Interleaved	320	320	2×	320	00 (/2)
Interleaved	320	320	4×	640	00 (/2)
Interleaved	160	160	8×	640	01 (/4)

The settings applied to PLL_PHASE[1:0] (register 02h[2:1]) and PLL_POL (register 02h[0]), allows adjustment of the phase and polarity of the sampling clock. This occurs at the input of the DAC core and depends mainly on the sampling frequency. Some examples are given in [Table 32 “Sample clock phase and polarity examples”](#).

Table 32. Sample clock phase and polarity examples

Mode	Input data rate (MHz)	Interpolation	Update rate (Msps)	PLL_PHASE [1:0]	PLL_POL
Dual-port	80	2×	160	01	1
Dual-port	80	4×	320	01	0
Dual-port	80	8×	640	01	1
Interleaved	160	2×	160	01	1
Interleaved	160	4×	320	01	0
Interleaved	160	8×	640	01	1

10.6 FIR filters

The DAC1005D650 integrates three selectable Finite Impulse Response (FIR) filters which enable the device to use interpolation rates of 2×, 4× or 8×.

All three interpolation filters have a stop-band attenuation of at least 80 dBc and a pass-band ripple of less than 0.0005 dB.

The coefficients of the interpolation filters are given in [Table 33 “Interpolation filter coefficients”](#).

Table 33. Interpolation filter coefficients

First interpolation filter ^[1]			Second interpolation filter ^[1]			Third interpolation filter ^[1]		
Lower	Upper	Value	Lower	Upper	Value	Lower	Upper	Value
H(1)	H(55)	-4	H(1)	H(23)	-2	H(1)	H(15)	-39
H(2)	H(54)	0	H(2)	H(22)	0	H(2)	H(14)	0
H(3)	H(53)	13	H(3)	H(21)	17	H(3)	H(13)	273
H(4)	H(52)	0	H(4)	H(20)	0	H(4)	H(12)	0
H(5)	H(51)	-34	H(5)	H(19)	-75	H(5)	H(11)	-1102
H(6)	H(50)	0	H(6)	H(18)	0	H(6)	H(10)	0
H(7)	H(49)	72	H(7)	H(17)	238	H(7)	H(9)	4964
H(8)	H(48)	0	H(8)	H(16)	0	H(8)	-	8192
H(9)	H(47)	-138	H(9)	H(15)	-660	-	-	-
H(10)	H(46)	0	H(10)	H(14)	0	-	-	-
H(11)	H(45)	245	H(11)	H(13)	2530	-	-	-
H(12)	H(44)	0	H(12)	-	4096	-	-	-
H(13)	H(43)	-408	-	-	-	-	-	-
H(14)	H(42)	0	-	-	-	-	-	-
H(15)	H(41)	650	-	-	-	-	-	-
H(16)	H(40)	0	-	-	-	-	-	-
H(17)	H(39)	-1003	-	-	-	-	-	-
H(18)	H(38)	0	-	-	-	-	-	-
H(19)	H(37)	1521	-	-	-	-	-	-
H(20)	H(36)	0	-	-	-	-	-	-
H(21)	H(35)	-2315	-	-	-	-	-	-
H(22)	H(34)	0	-	-	-	-	-	-
H(23)	H(33)	3671	-	-	-	-	-	-
H(24)	H(32)	0	-	-	-	-	-	-
H(25)	H(31)	-6642	-	-	-	-	-	-
H(26)	H(30)	0	-	-	-	-	-	-
H(27)	H(29)	20756	-	-	-	-	-	-
H(28)		32768	-	-	-	-	-	-

[1] H(n) is the digital filter coefficient.

10.7 Quadrature modulator and NCO

The quadrature modulator allows the 10-bit I and Q data to be mixed with the carrier signal generated by the Numerically Controlled Oscillator (NCO).

The frequency of the NCO is programmed over 32-bit and allows the sign of the sine component to be inverted in order to operate positive or negative, lower or upper single sideband up-conversion.

10.7.1 NCO in 32-bit

When using the NCO, the frequency can be set by the four registers `FREQNCO_LSB`, `FREQNCO_LISB`, `FREQNCO_UISB` and `FREQNCO_MSB` over 32 bits.

The frequency for the NCO in 32-bit is calculated as follows:

$$f_{NCO} = \frac{M \times f_s}{2^{32}} \quad (1)$$

where M is the decimal representation of `FREQ_NCO[31:0]`.

The phase of the NCO can be set from 0° to 360° by both registers `PHINCO_LSB` and `PHINCO_MSB` over 16 bits.

The default setting is $f_{NCO} = 96$ MHz when $f_s = 640$ Msps and the default phase is 0°.

10.7.2 Low-power NCO

When using the low-power NCO, the frequency can be set by the 5 MSB of register `FREQNCO_MSB`.

The frequency for the low-power NCO is calculated as follows:

$$f_{NCO} = \frac{M \times f_s}{2^5} \quad (2)$$

where M is the decimal representation of `FREQ_NCO[31:27]`.

The phase of the low-power NCO can be set by the 5 MSB of the register `PHINCO_MSB`.

10.7.3 Minus 3 dB

During normal use, a full-scale pattern will also be full scale at the output of the DAC. Nevertheless, when the I and Q data are simultaneously close to full scale, some clipping can occur and the `Minus_3dB` function can be used to reduce gain by 3 dB in the modulator. This is to keep a full-scale range at the output of the DAC without added interferers.

10.8 x / (sin x)

Due to the roll-off effect of the DAC, a selectable FIR filter is inserted to compensate for the $(\sin x) / x$ effect. This filter introduces a DC loss of 3.4 dB. The coefficients are represented in [Table 34 “Inversion filter coefficients”](#).

Table 34. Inversion filter coefficients

First interpolation filter ^[1]		
Lower	Upper	Value
H(1)	H(9)	2
H(2)	H(8)	-4
H(3)	H(7)	10
H(4)	H(6)	-35
H(5)	-	401

[1] H(n) is the digital filter coefficient.

10.9 DAC transfer function

The full-scale output current for each DAC is the sum of the two complementary current outputs:

$$I_{O(fs)} = I_{IOUTP} + I_{IOUTN} \tag{3}$$

The output current depends on the digital input data:

$$I_{IOUTP} = I_{O(fs)} \times \left(\frac{DATA}{1023} \right) \tag{4}$$

$$I_{IOUTN} = I_{O(fs)} \times \left(\frac{1023 - DATA}{1023} \right) \tag{5}$$

The setting applied to CODING (register 00h[2]; see [Table 9 “Register allocation map”](#)) defines whether the DAC1005D650 operates with a binary input or a two’s complement input.

[Table 35 “DAC transfer function”](#) shows the output current as a function of the input data, when $I_{O(fs)} = 20 \text{ mA}$.

Table 35. DAC transfer function

Data (Decimal)	I9/Q9 to I0/Q0		IOUTP	IOUTN
	Binary	Two’s complement		
0	00 0000 0000	10 0000 0000	0 mA	20 mA
...
512	10 0000 0000	00 0000 0000	10 mA	10 mA
...
1023	11 1111 1111	01 1111 1111	20 mA	0 mA

10.10 Full-scale current

10.10.1 Regulation

The DAC1005D650 reference circuitry integrates an internal bandgap reference voltage which delivers a 1.25 V reference to the GAPOUT pin. It is recommended to decouple pin GAPOUT using a 100 nF capacitor.

The reference current is generated using an external resistor of 910 Ω (1 %) connected to pin VIRES. A control amplifier sets the appropriate full-scale current ($I_{O(fs)}$) for both DACs (see [Figure 11 “Internal reference configuration”](#)).

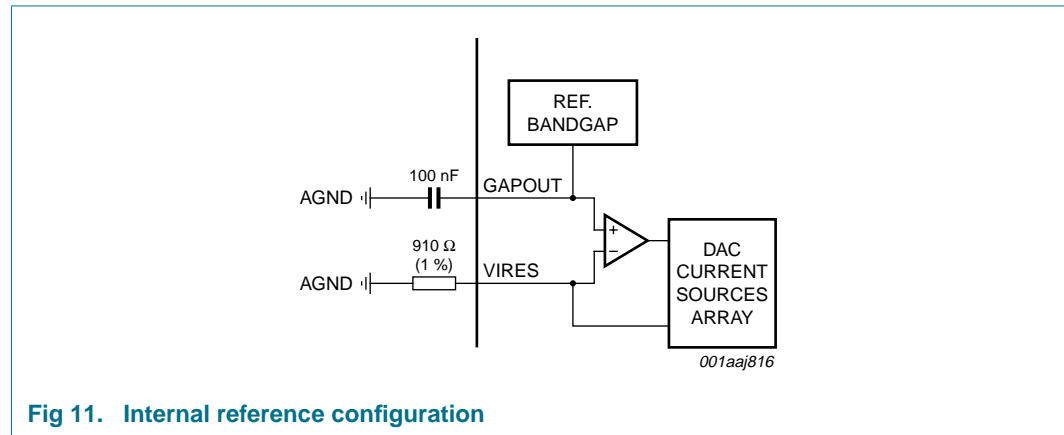

Fig 11. Internal reference configuration

This configuration is optimum for temperature drift compensation because the bandgap reference voltage can be matched to the voltage across the feedback resistor.

The DAC current can also be set by applying an external reference voltage to the non-inverting input pin GAPOUT and disabling the internal bandgap reference voltage with GAP_PD (register 00h[0]; see [Table 10 “COMMON register \(address 00h\) bit description”](#)).

10.10.2 Full-scale current adjustment

The default full-scale current ($I_{O(fs)}$) is 20 mA. It can be further adjusted for each DAC using SPI. The adjustment range is between 1.6 mA to 22 mA ± 10 %.

The settings applied to DAC_A_GAIN_COARSE[3:0] (register 0Ah; see [Table 20 “DAC_A_Cfg_2 register \(address 0Ah\) bit description”](#) and register 0Bh; see [Table 21 “DAC_A_Cfg_3 register \(address 0Bh\) bit description”](#)) and to DAC_B_GAIN_COARSE[3:0] (register 0Dh; see [Table 23 “DAC_B_Cfg_2 register \(address 0Dh\) bit description”](#) and register 0Eh; see [Table 24 “DAC_B_Cfg_3 register \(address 0Eh\) bit description”](#)) define the coarse variation of the full-scale current (see [Table 36 “ \$I_{O\(fs\)}\$ coarse adjustment”](#)).

Table 36. $I_{O(fs)}$ coarse adjustment
Default settings are shown highlighted.

DAC_GAIN_COARSE[3:0]		$I_{O(fs)}$ (mA)
Decimal	Binary	
0	0000	1.6
1	0001	3.0
2	0010	4.4
3	0011	5.8
4	0100	7.2
5	0101	8.6
6	0110	10.0
7	0111	11.4

Table 36. $I_{O(fs)}$ coarse adjustment ...continued
Default settings are shown highlighted.

DAC_GAIN_COARSE[3:0]		$I_{O(fs)}$ (mA)
Decimal	Binary	
8	1000	12.8
9	1001	14.2
10	1010	15.6
11	1011	17.0
12	1100	18.5
13	1101	20.0
14	1110	21.0
15	1111	22.0

The settings applied to DAC_A_GAIN_FINE[5:0] (register 0Ah; see [Table 20 “DAC_A_Cfg_2 register \(address 0Ah\) bit description”](#)) and to DAC_B_GAIN_FINE[5:0] (register 0Dh; see [Table 23 “DAC_B_Cfg_2 register \(address 0Dh\) bit description”](#)) define the fine variation of the full-scale current (see [Table 37 “ \$I_{O\(fs\)}\$ fine adjustment”](#)).

Table 37. $I_{O(fs)}$ fine adjustment
Default settings are shown highlighted.

DAC_GAIN_FINE[5:0]		Delta $I_{O(fs)}$
Decimal	Two's complement	
-32	10 0000	-10 %
...
0	00 0000	0
...
+31	01 1111	+10 %

The coding of the fine gain adjustment is two's complement.

10.11 Digital offset adjustment

When the DAC1005D650 analog output is DC connected to the next stage, the digital offset correction can be used to adjust the common mode level at the output of the DAC. It adds an offset at the end of the digital part, just before the DAC.

The settings applied to DAC_A_OFFSET[8:0] (register 09h; see [Table 19 “DAC_A_Cfg_1 register \(address 09h\) bit description”](#)) and register 0Bh; see [Table 21 “DAC_A_Cfg_3 register \(address 0Bh\) bit description”](#)) and to “DAC_B_OFFSET[8:0]” (register 0Ch; see [Table 22 “DAC_B_Cfg_1 register \(address 0Ch\) bit description”](#)) and register 0Eh; see [Table 24 “DAC_B_Cfg_3 register \(address 0Eh\) bit description”](#)) define the range of variation of the digital offset (see [Table 38 “Digital offset adjustment”](#)).

Table 38. Digital offset adjustment

Default settings are shown highlighted.

DAC_OFFSET[8:0]		Offset applied
Decimal	Two's complement	
-256	1 0000 0000	-256
-255	1 0000 0001	-255
...
-1	1 1111 1111	-1
0	0 0000 0000	0
+1	0 0000 0001	+1
...
+254	0 1111 1110	+254
+255	0 1111 1111	+255

10.12 Analog output

The DAC1005D650 has two output channels each of which produces two complementary current outputs. These allow the even-order harmonics and noise to be reduced. The pins are IOUTAP/IOUTAN and IOUTBP/IOUTBN respectively and need to be connected using a load resistor R_L to the 3.3 V analog power supply ($V_{DDA(3V3)}$).

Refer to [Figure 12](#) for the equivalent analog output circuit of one DAC. This circuit consists of a parallel combination of NMOS current sources, and their associated switches, for each segment.

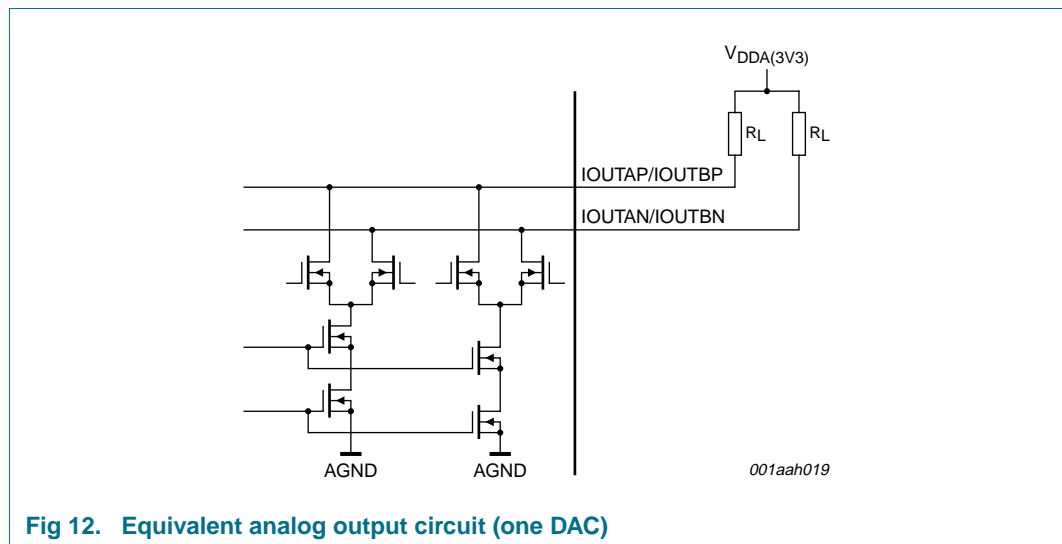

Fig 12. Equivalent analog output circuit (one DAC)

The cascode source configuration increases the output impedance of the source, thus improving the dynamic performance of the DAC by introducing less distortion.

The device can provide an output level of up to $2 V_{O(p-p)}$ depending on the application, the following stages and the targeted performances.

10.13 Auxiliary DACs

The DAC1005D650 integrates two auxiliary DACs that can be used to compensate for any offset between the DAC and the next stage in the transmission path.

Both auxiliary DACs have a resolution of 10-bit and are current sources (referenced to ground). The settings applied to AUX_A[9:0] and AUX_B[9:0] define the offset data.

$$I_{O(AUX)} = I_{AUXP} + I_{AUXN} \tag{6}$$

The output current depends on the auxiliary DAC data:

$$AUXP = I_{O(AUX)} \times \left(\frac{AUX[9:0]}{1023} \right) \tag{7}$$

$$AUXN = I_{O(AUX)} \times \left(\frac{(1023 - AUX[9:0])}{1023} \right) \tag{8}$$

[Table 39 “Auxiliary DAC transfer function”](#) shows the output current as a function of the auxiliary DAC data.

Table 39. Auxiliary DAC transfer function

Default settings are shown highlighted.

Data	AUX_A[9:0] and AUX_B[9:0] (binary)	I _{AUXP}	I _{AUXN}
0	00 0000 0000	0 mA	2.2 mA
...
512	10 0000 0000	1.1 mA	1.1 mA
...
1023	11 1111 1111	2.2 mA	0 mA

10.14 Output configuration

10.14.1 Basic output configuration

The use of a differentially-coupled transformer output provides optimum distortion performance (see [Figure 13 “Differential output with transformer; \$V_{o\(dif\)\(p-p\)} = 1 V\$ ”](#)). In addition, it helps to match the impedance and provides electrical isolation.

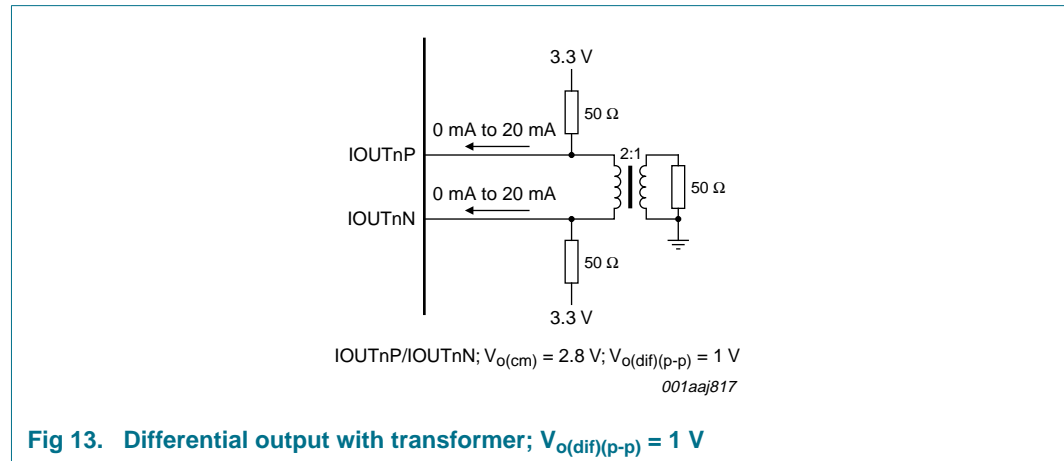

Fig 13. Differential output with transformer; $V_{o(dif)(p-p)} = 1 V$

The DAC1005D650 can operate up to 2 $V_{o(p-p)}$ differential outputs. In this configuration, it is recommended to connect the center tap of the transformer to a 62 Ω resistor connected to the 3.3 V analog power supply, in order to adjust the DC common mode to approximately 2.7 V (see [Figure 14 “Differential output with transformer; \$V_{o\(dif\)\(p-p\)} = 2 V\$ ”](#)).

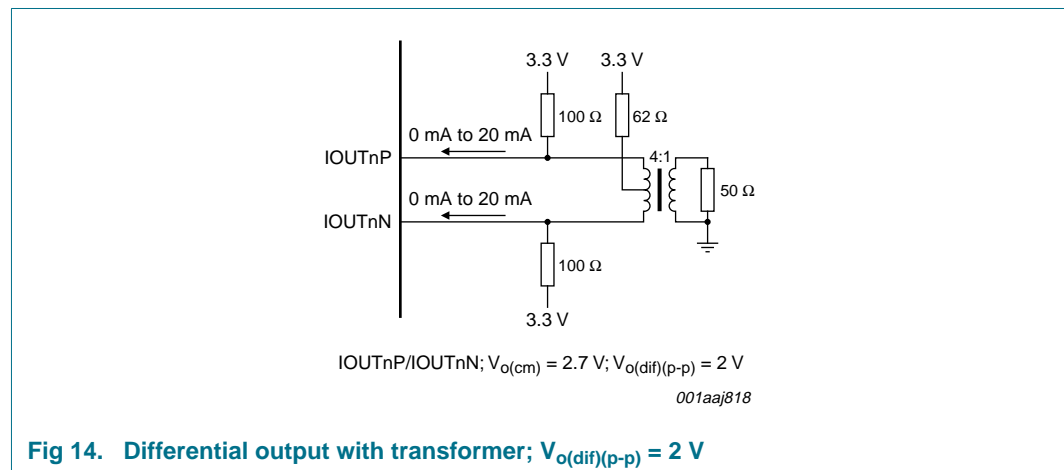

Fig 14. Differential output with transformer; $V_{o(dif)(p-p)} = 2 V$

10.14.2 DC interface to an AQM

When the system operation requires to keep the DC component of the spectrum, the DAC1005D650 can use a DC interface to connect to an Analog Quadrature Modulator (AQM). In this case, the offset compensation for LO cancellation can be made with the use of the digital offset control in the DAC.

[Figure 15](#) provides an example of a connection to an AQM with a 1.7 V common mode input level.

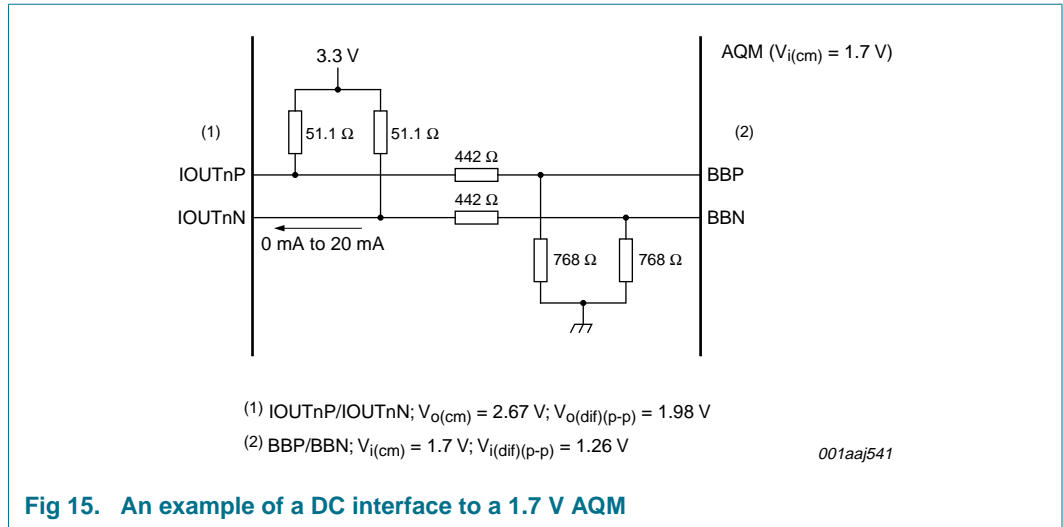

Fig 15. An example of a DC interface to a 1.7 V AQM

Figure 16 provides an example of a connection to an AQM with a 3.3 V_{i(cm)} common mode input level.

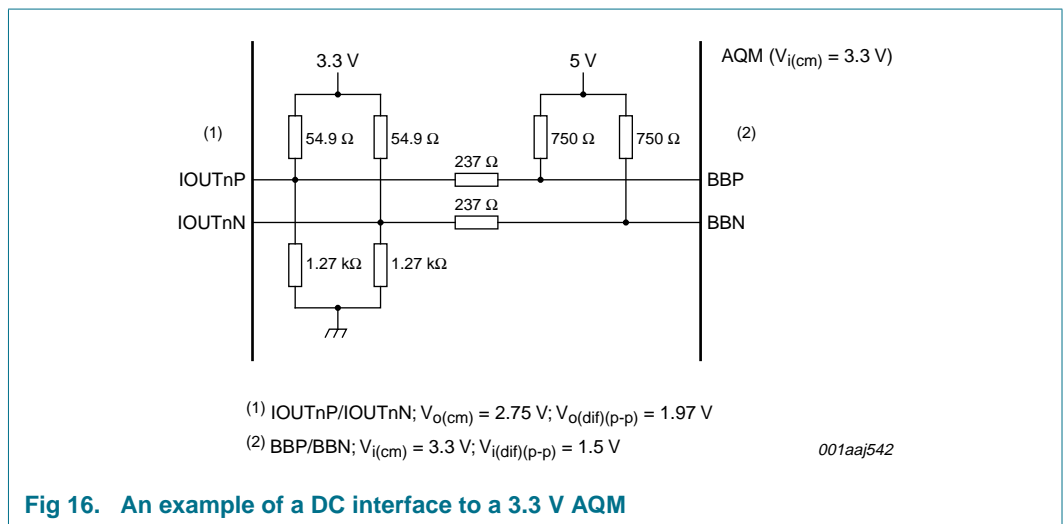

Fig 16. An example of a DC interface to a 3.3 V AQM

The auxiliary DACs can be used to control the offset in a precise range or with precise steps.

Figure 17 provides an example of a DC interface with the auxiliary DACs to an AQM with a 1.7 V common mode input level.

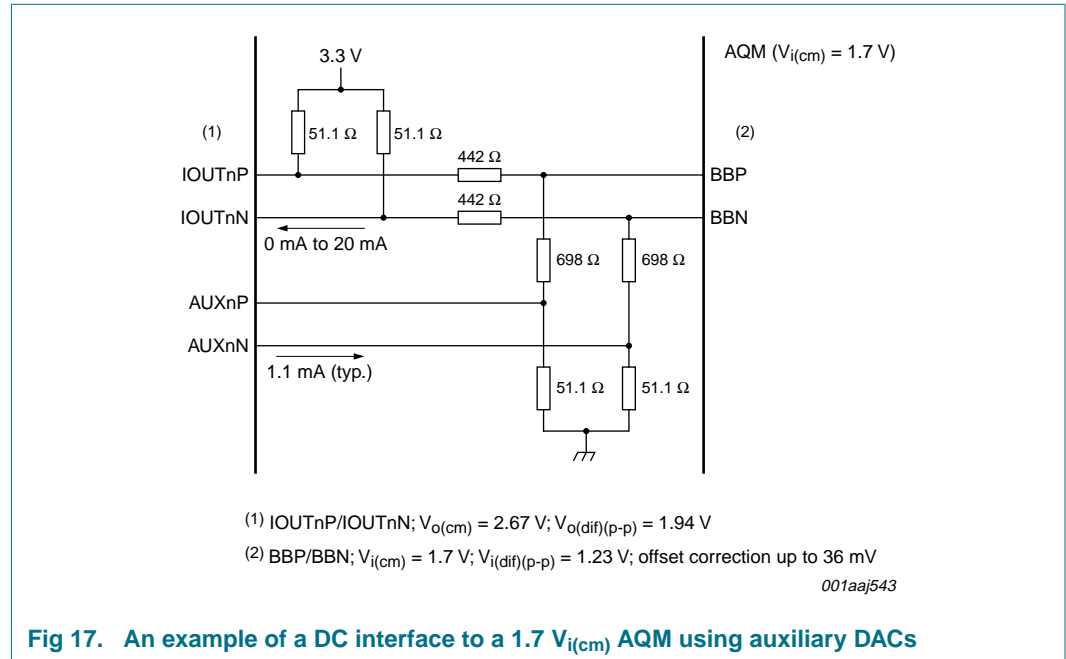

Fig 17. An example of a DC interface to a 1.7 $V_{i(cm)}$ AQM using auxiliary DACs

Figure 18 provides an example of a DC interface with the auxiliary DACs to an AQM with a 3.3 V common mode input level.

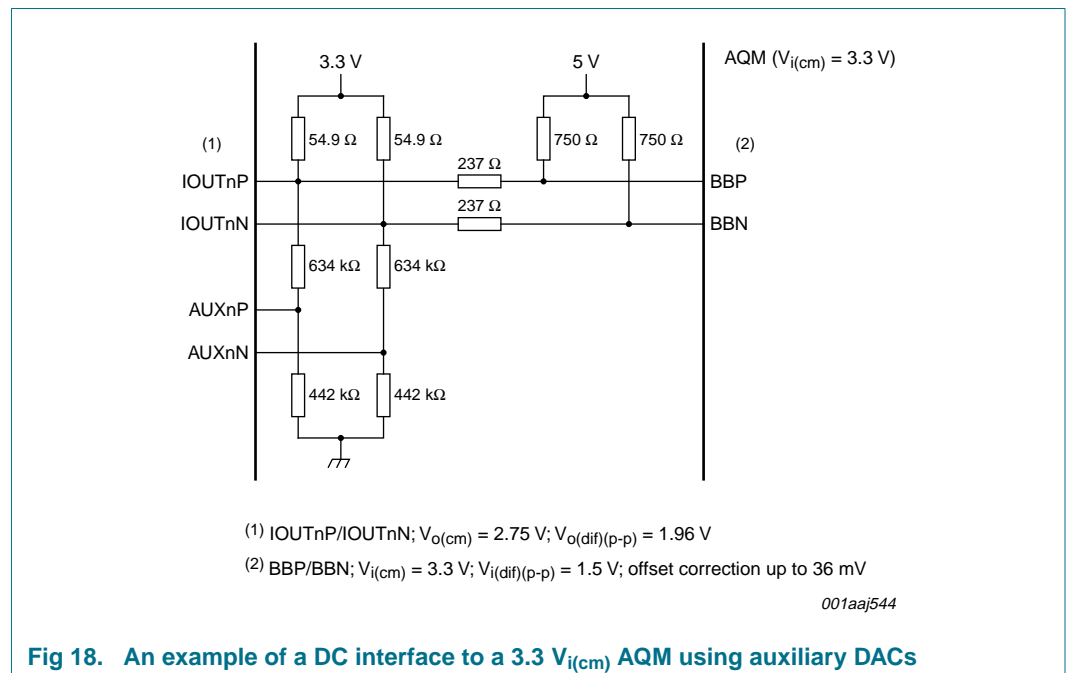

Fig 18. An example of a DC interface to a 3.3 $V_{i(cm)}$ AQM using auxiliary DACs

The constraints to adjust the interface are the output compliance range of the DAC and the auxiliary DACs, the input common mode level of the AQM, and the range of offset correction required.

10.14.3 AC interface to an AQM

When the Analog Quadrature Modulator (AQM) common mode voltage is close to ground, the DAC1005D650 must be AC-coupled and the auxiliary DACs are needed for offset correction.

Figure 18 provides an example of a connection to an AQM with a 0.5 V common mode input level when using auxiliary DACs.

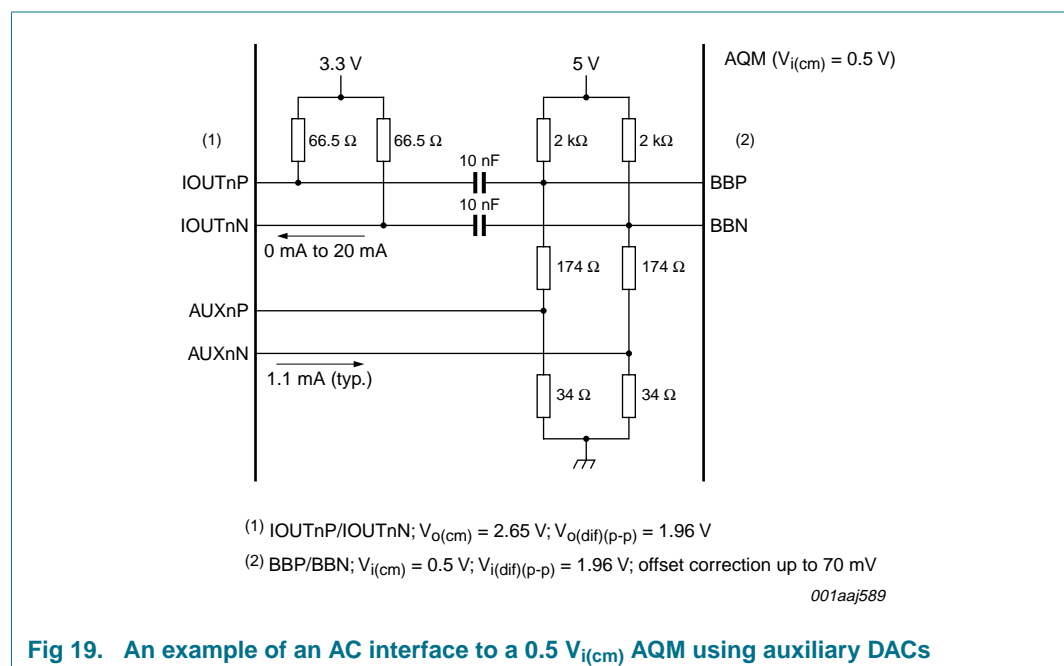

Fig 19. An example of an AC interface to a 0.5 $V_{i(cm)}$ AQM using auxiliary DACs

10.15 Power and grounding

In order to obtain optimum performance, it is recommended that the 1.8 V analog power supplies on pins 5, 11, 71, 77 and 99 should not be connected with those on pins 70, 79, 81, 83, 93, 95 and 97 on the top layer.

To optimize the decoupling, the power supplies should be decoupled with the following pins:

- $V_{DD(1V8)}$: pin 26 with 27; pin 32 with 33; pin 36 with 37; pin 40 with 39; pin 44 with 43 and pin 50 with 49.
- $V_{DD(IO)(3V3)}$: pin 16 with 17 and pin 60 with 59.
- $V_{DDA(1V8)}$: pin 5 with 4; pin 6 with 7; pin 11 with 10; pin 71 with 72; pin 77 with 78; pins 79, 81, 83 with 80, 82, 84; pins 93, 95, 97 with 92, 94, 96 and pin 99 with 98.
- $V_{DDA(3V3)}$: pin 1 with 100 and pin 75 with 76.

10.16 Alternative parts

The following alternative parts are available.

Table 40. Alternative parts

Type number	Description	Sampling frequency
DAC1205D650	dual 12-bit DAC	up to 650 Msps
DAC1405D650	dual 14-bit DAC	up to 650 Msps

11. Package outline

HTQFP100: plastic thermal enhanced thin quad flat package; 100 leads; body 14 x 14 x 1 mm; exposed die pad

SOT638-1

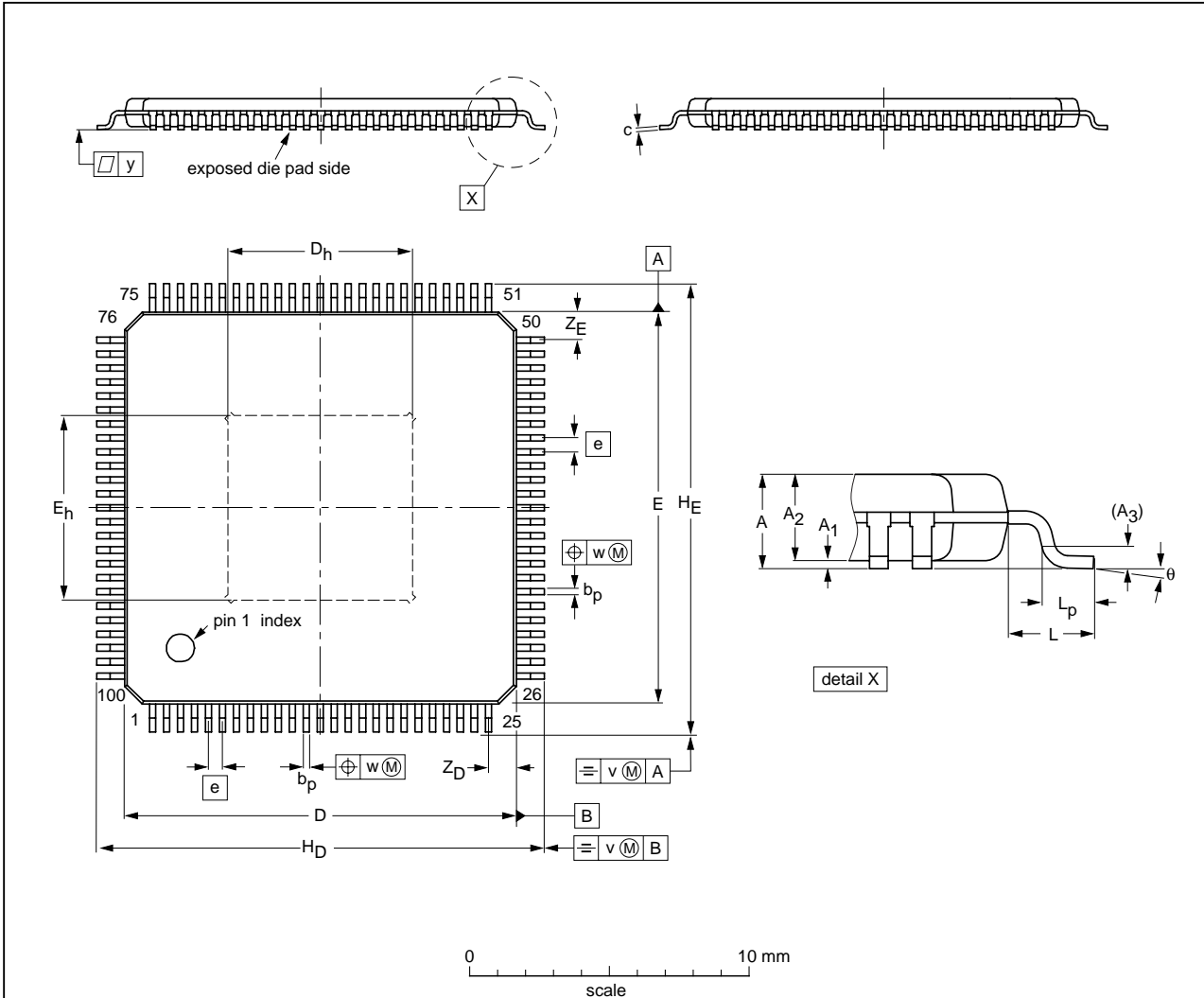

DIMENSIONS (mm are the original dimensions)

UNIT	A max.	A ₁	A ₂	A ₃	b _p	c	D ⁽¹⁾	D _h	E ⁽¹⁾	E _h	e	H _D	H _E	L	L _p	v	w	y	Z _D ⁽¹⁾	Z _E ⁽¹⁾	θ
mm	1.2	0.15 0.05	1.05 0.95	0.25	0.27 0.17	0.20 0.09	14.1 13.9	7.1 6.1	14.1 13.9	7.1 6.1	0.5	16.15 15.85	16.15 15.85	1	0.75 0.45	0.2	0.08	0.08	1.15 0.85	1.15 0.85	7° 0°

Note

1. Plastic or metal protrusions of 0.25 mm maximum per side are not included.

OUTLINE VERSION	REFERENCES				EUROPEAN PROJECTION	ISSUE DATE
	IEC	JEDEC	JEITA			
SOT638-1		MS-026				-03-04-07 05-02-02

Fig 20. Package outline SOT638-1 (HTQFP100)

12. Abbreviations

Table 41. Abbreviations

Acronym	Description
BB	BaseBand
CDMA	Code Division Multiple Access
CML	Current Mode Logic
CMOS	Complementary Metal-Oxide Semiconductor
DAC	Digital-to-Analog Converter
FIR	Finite Impulse Response
GSM	Global System for Mobile communications
IF	Intermediate Frequency
IMD3	Third-order Inter Modulation Distortion
LISB	Lower Intermediate Significant Byte
LMDS	Local Multipoint Distribution Service
LSB	Least Significant Bit
LTE	Long Term Evolution
LVDS	Low-Voltage Differential Signaling
MMDS	Multichannel Multipoint Distribution Service
MSB	Most Significant Bit
NCO	Numerically Controlled Oscillator
NMOS	Negative Metal-Oxide Semiconductor
PLL	Phase-Locked Loop
SFDR	Spurious-Free Dynamic Range
SPI	Serial Peripheral Interface
TD-SCDMA	Time Division-Synchronous Code Division Multiple Access
UISB	Upper Intermediate Significant Byte
WCDMA	Wideband Code Division Multiple Access
WiMAX	Worldwide Interoperability for Microwave Access

13. Glossary

Spurious-Free Dynamic Range (SFDR): — The ratio between the RMS value of the reconstructed output sine wave and the RMS value of the largest spurious observed (harmonic and non-harmonic, excluding DC component) in the frequency domain.

Intermodulation Distortion (IMD): — From a dual-tone digital input sine wave (these two frequencies being close together), the intermodulation distortion products IMD2 and IMD3 (respectively, 2nd and 3rd order components) are defined below.

IMD2 — The ratio of the RMS value of either tone to the RMS value of the worst 2nd order intermodulation product.

IMD3 — The ratio of the RMS value of either tone to the RMS value of the worst 3rd order intermodulation product.

Restricted Bandwidth Spurious-Free Dynamic Range — The ratio of the RMS value of the reconstructed output sine wave to the RMS value of the noise, including the harmonics, in a given bandwidth centered around f_{offset} .

14. Revision history

Table 42. Revision history

Document ID	Release date	Data sheet status	Change notice	Supersedes
DAC1005D650_1	20090728	Product data sheet	-	-

15. Legal information

15.1 Data sheet status

Document status ^{[1][2]}	Product status ^[3]	Definition
Objective [short] data sheet	Development	This document contains data from the objective specification for product development.
Preliminary [short] data sheet	Qualification	This document contains data from the preliminary specification.
Product [short] data sheet	Production	This document contains the product specification.

[1] Please consult the most recently issued document before initiating or completing a design.

[2] The term 'short data sheet' is explained in section "Definitions".

[3] The product status of device(s) described in this document may have changed since this document was published and may differ in case of multiple devices. The latest product status information is available on the Internet at URL <http://www.nxp.com>.

15.2 Definitions

Draft — The document is a draft version only. The content is still under internal review and subject to formal approval, which may result in modifications or additions. NXP Semiconductors does not give any representations or warranties as to the accuracy or completeness of information included herein and shall have no liability for the consequences of use of such information.

Short data sheet — A short data sheet is an extract from a full data sheet with the same product type number(s) and title. A short data sheet is intended for quick reference only and should not be relied upon to contain detailed and full information. For detailed and full information see the relevant full data sheet, which is available on request via the local NXP Semiconductors sales office. In case of any inconsistency or conflict with the short data sheet, the full data sheet shall prevail.

15.3 Disclaimers

General — Information in this document is believed to be accurate and reliable. However, NXP Semiconductors does not give any representations or warranties, expressed or implied, as to the accuracy or completeness of such information and shall have no liability for the consequences of use of such information.

Right to make changes — NXP Semiconductors reserves the right to make changes to information published in this document, including without limitation specifications and product descriptions, at any time and without notice. This document supersedes and replaces all information supplied prior to the publication hereof.

Suitability for use — NXP Semiconductors products are not designed, authorized or warranted to be suitable for use in medical, military, aircraft, space or life support equipment, nor in applications where failure or malfunction of an NXP Semiconductors product can reasonably be expected to result in personal injury, death or severe property or environmental

damage. NXP Semiconductors accepts no liability for inclusion and/or use of NXP Semiconductors products in such equipment or applications and therefore such inclusion and/or use is at the customer's own risk.

Applications — Applications that are described herein for any of these products are for illustrative purposes only. NXP Semiconductors makes no representation or warranty that such applications will be suitable for the specified use without further testing or modification.

Limiting values — Stress above one or more limiting values (as defined in the Absolute Maximum Ratings System of IEC 60134) may cause permanent damage to the device. Limiting values are stress ratings only and operation of the device at these or any other conditions above those given in the Characteristics sections of this document is not implied. Exposure to limiting values for extended periods may affect device reliability.

Terms and conditions of sale — NXP Semiconductors products are sold subject to the general terms and conditions of commercial sale, as published at <http://www.nxp.com/profile/terms>, including those pertaining to warranty, intellectual property rights infringement and limitation of liability, unless explicitly otherwise agreed to in writing by NXP Semiconductors. In case of any inconsistency or conflict between information in this document and such terms and conditions, the latter will prevail.

No offer to sell or license — Nothing in this document may be interpreted or construed as an offer to sell products that is open for acceptance or the grant, conveyance or implication of any license under any copyrights, patents or other industrial or intellectual property rights.

Export control — This document as well as the item(s) described herein may be subject to export control regulations. Export might require a prior authorization from national authorities.

15.4 Trademarks

Notice: All referenced brands, product names, service names and trademarks are the property of their respective owners.

16. Contact information

For more information, please visit: <http://www.nxp.com>

For sales office addresses, please send an email to: salesaddresses@nxp.com

17. Contents

1	General description	1	14	Revision history	39
2	Features	1	15	Legal information	40
3	Applications	2	15.1	Data sheet status	40
4	Ordering information	2	15.2	Definitions	40
5	Block diagram	3	15.3	Disclaimers	40
6	Pinning information	4	15.4	Trademarks	40
6.1	Pinning	4	16	Contact information	40
6.2	Pin description	5	17	Contents	41
7	Limiting values	8			
8	Thermal characteristics	8			
9	Characteristics	9			
10	Application information	13			
10.1	General description	13			
10.2	Serial interface (SPI)	13			
10.2.1	Protocol description	13			
10.2.2	SPI timing description	14			
10.2.3	Detailed descriptions of registers	15			
10.2.4	Registers detailed description	17			
10.3	Input data	21			
10.3.1	Dual-port mode	21			
10.3.2	Interleaved mode	21			
10.4	Input clock	22			
10.5	Timing	23			
10.6	FIR filters	25			
10.7	Quadrature modulator and NCO	26			
10.7.1	NCO in 32-bit	26			
10.7.2	Low-power NCO	26			
10.7.3	Minus 3 dB	26			
10.8	x / (sin x)	26			
10.9	DAC transfer function	27			
10.10	Full-scale current	27			
10.10.1	Regulation	27			
10.10.2	Full-scale current adjustment	28			
10.11	Digital offset adjustment	29			
10.12	Analog output	30			
10.13	Auxiliary DACs	31			
10.14	Output configuration	32			
10.14.1	Basic output configuration	32			
10.14.2	DC interface to an AQM	32			
10.14.3	AC interface to an AQM	35			
10.15	Power and grounding	35			
10.16	Alternative parts	36			
11	Package outline	37			
12	Abbreviations	38			
13	Glossary	39			

Please be aware that important notices concerning this document and the product(s) described herein, have been included in section 'Legal information'.



© NXP B.V. 2009.

All rights reserved.

For more information, please visit: <http://www.nxp.com>

For sales office addresses, please send an email to: salesaddresses@nxp.com

Date of release: 28 July 2009

Document identifier: DAC1005D650_1